

RoHS

COSEL

2026.2

EMI/EMC FILTERS

5-year
Warranty



Before using our product

Warning

- ◆ When the product is in operation, inside there are components which have high voltage and high temperature. They may cause electrical shock or burn if you touch the internal components.
- ◆ Do not modify, disassemble or remove the enclosure of the product. This may cause electrical shock, burn or fire hazard.
- ◆ When the product is operating, keep your hands and face away from it. This may cause injury by accident.

Attention

- ◆ It is necessary to read the instruction manual and catalog. Please confirm the content of the catalog and instruction manual before you use our products.
- ◆ We make every effort to improve quality and reliability of our products. However the product may accidentally malfunction or fail. Therefore, please ensure fail safe function of your product when our product is used in equipment where high reliability is required (such as nuclear control, aerospace, life-support, traffic control etc.).
- ◆ If the product is used in an environment where water, moisture, dust, strong electromagnetic field or corrosive gas is present, it may cause the failure of the internal components of the product.
- ◆ The life-limited components (such as electrolytic capacitor, internal fan.) should be replaced periodically. Please arrange for the appropriate overhaul period depending on the usage environment.
- ◆ When you export the product, please comply with all appropriate export-related laws, and procedures.

* The content of the catalog may be changed without advanced notice.
If necessary, please request product specification from our representatives before ordering.

EMI/EMC Filter Contents

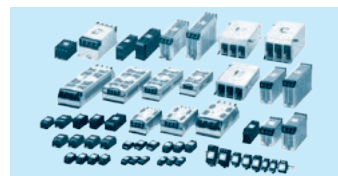

Single-phase type

	Rated voltage	Series	Rated current [A]									Released year	Option		
			3A	4A	6A	10A	16A	20A	30A	40A	50A		60A	D	F
1-stage	AC250V	EAC	●	—	●	●	●	●	●	—	—	—	'10	●	—
	AC250V	EAM	●	—	●	●	●	●	●	—	—	—	'10	●	—
	AC250V	EAP	●	—	●	●	●	●	●	—	—	—	'10	●	—
	AC250V	ESC	●	—	●	●	●	—	—	—	—	—	'10	●	—
	AC250V	ESM	●	—	●	●	●	—	—	—	—	—	'10	●	—
	AC250V	ESP	●	—	●	●	●	—	—	—	—	—	'10	●	—
	AC250V	NAC	—	●	●	●	●	●	—	—	—	—	'05	●	—
	AC250V	NAM	—	●	●	●	●	●	●	—	—	—	'05	●	—
	AC250V	NAH	—	—	●	●	●	●	●	—	—	—	'06	●	—
	AC250V	NAP	—	●	●	●	●	●	●	—	—	—	'05	●	—
	AC277V DC300V	NAC	—	—	—	—	—	—	—	●	●	●	NEW '21	—	●
	AC277V DC300V	NAM	—	—	—	—	—	—	—	●	●	●	NEW '21	—	—
	AC277V DC300V	NAH	—	—	—	—	—	—	—	●	●	●	NEW '21	—	●
AC277V DC300V	NAP	—	—	—	—	—	—	—	●	●	●	NEW '21	—	●	
2-stage	AC250V	NBH	—	—	●	●	●	●	●	—	—	—	'07	●	—
	AC250V	NBC	—	—	●	●	●	●	●	—	—	—	'07	●	—
	AC250V	NBM	—	—	●	●	●	●	●	—	—	—	'07	●	—

Option -D: DIN rail installation type -F: High input voltage (Rated voltage 500VAC/600VDC)

Three-phase type

	Rated voltage	Series	Rated current [A]																	Released year	Option														
			4A	6A	10A	20A	25A	30A	36A	40A	50A	60A	64A	80A	100A	120A	125A	150A	160A		200A	250A	300A	400A	600A	800A	1000A	D	G	H	L	S	U		
1-stage	AC500V	JAC	—	●	●	●	—	●	—	—	—	—	—	—	—	—	—	—	—	—	—	—	—	—	—	—	—	—	'14	●	—	●	—	—	●
		TAC	●	●	●	●	—	●	—	—	—	—	—	—	—	—	—	—	—	—	—	—	—	—	—	—	—	—	'19	—	—	●	—	—	●
		TAH	●	●	●	●	—	●	—	—	—	—	—	—	—	—	—	—	—	—	—	—	—	—	—	—	—	'06	●	—	—	—	—	—	
		TAC	—	—	—	—	—	—	—	—	—	—	—	—	—	—	—	—	—	—	—	—	—	—	—	—	—	'08	—	—	—	—	—	●	
		TAH	—	—	—	—	—	—	—	—	—	—	—	—	—	—	—	—	—	—	—	—	—	—	—	—	—	'16	—	—	—	—	—	●	
		TAC	—	—	—	—	—	—	—	—	—	—	—	—	—	—	—	—	—	—	—	—	—	—	—	—	—	'09	—	—	—	—	—	●	
2-stage	AC500V	FTA	—	—	—	—	—	—	—	—	—	—	—	—	—	—	—	—	—	—	—	—	—	—	—	—	—	'13	—	—	●	—	—	●	
			—	—	—	—	—	—	—	—	—	—	—	—	—	—	—	—	—	—	—	—	—	—	—	—	—	'11	—	—	●	—	—	●	
2-stage	AC500V	YAC	—	—	—	—	—	—	—	—	—	—	—	—	—	—	—	—	—	—	—	—	—	—	—	—	—	NEW '23	—	—	—	—	—	—	
			—	—	—	—	—	—	—	—	—	—	—	—	—	—	—	—	—	—	—	—	—	—	—	—	—	NEW '25	—	—	—	—	—	—	
2-stage	AC500V	TBC	—	—	—	—	—	—	—	—	—	—	—	—	—	—	—	—	—	—	—	—	—	—	—	—	—	'08	—	—	—	—	—	—	
			—	—	—	—	—	—	—	—	—	—	—	—	—	—	—	—	—	—	—	—	—	—	—	—	—	'09	—	—	—	—	—	—	
			—	—	—	—	—	—	—	—	—	—	—	—	—	—	—	—	—	—	—	—	—	—	—	—	—	'16	—	—	—	—	—	—	
2-stage	AC500V	FTB	—	—	—	—	—	—	—	—	—	—	—	—	—	—	—	—	—	—	—	—	—	—	—	—	—	'17	—	—	—	—	—	—	
			—	—	—	—	—	—	—	—	—	—	—	—	—	—	—	—	—	—	—	—	—	—	—	—	—	'18	—	—	—	—	—	—	
			—	—	—	—	—	—	—	—	—	—	—	—	—	—	—	—	—	—	—	—	—	—	—	—	—	'17	—	—	—	—	—	—	
multi-stage	AC500V	TSC	—	—	—	—	—	—	—	—	—	—	—	—	—	—	—	—	—	—	—	—	—	—	—	—	'13	—	—	—	—	—	—		
			—	—	—	—	—	—	—	—	—	—	—	—	—	—	—	—	—	—	—	—	—	—	—	—	—	NEW '21	—	—	—	—	—	—	
multi-stage	AC500V	TSD	—	—	—	—	—	—	—	—	—	—	—	—	—	—	—	—	—	—	—	—	—	—	—	—	NEW '23	—	—	—	—	—	—		
			—	—	—	—	—	—	—	—	—	—	—	—	—	—	—	—	—	—	—	—	—	—	—	—	—	NEW '23	—	—	—	—	—	—	

Option -D: DIN rail installation type -G: With switch of line to ground capacitor -H: Ultra high-attenuation type
 -L: Ultra high-attenuation type for EU -S: Hexagon socket head cap screw -U: Improve differential mode attenuation (Rated voltage 250V)
 (Standard type is Hexagon head screw)

















DC type

	Rated voltage	Series	Rated current [A]				Released year	Option	
			1A	3A	6A	10A		D	T
1-stage	DC±50V	SNA	●	●	●	—	'05	●	● (Excluding 1A and 3A)
	DC50V	SNR	—	—	—	●	'07	●	●

Option -D: DIN rail installation type -T: Terminal block type

EMI/EMC Filter Selection Guide by Type

Refer to EMI/EMC filter selection flow chart for options.

Series	Features		Rated Voltage (voltage range max)	Rated Current																						
				1	3	4	6	10	16	20	25	30	36	40	50	60	64	80	100	120	125	150	160	200	250	300
Single-phase EMI/EMC filter		EA Series 1-stage filter	Small size	Screw type	EAC: Attenuation for low frequency band (150kHz to 1MHz) EAM: Low leakage current EAP: Outside impulse attenuation	250VAC	3A 6A 10A 16A 20A 30A																			
		ES Series 1-stage filter	Small size	Screwless type	ESC: Attenuation for low frequency band (150kHz to 1MHz) ESM: Low leakage current ESP: Outside impulse attenuation	250VAC	3A 6A 10A 16A																			
		NA Series 1-stage filter	General purpose	Screw type	NAC: High-attenuation for low frequency band (150kHz to 1MHz) NAM: Low leakage current NAH: Ultra high-attenuation for ultra low frequency band (9kHz to 1MHz) NAP: Outside impulse high-attenuation	250VAC	4A 6A 10A 16A 20A 30A * NAH only, 6A to 30A																			
					277VAC (305VAC) 300VDC (400VDC)	40A 50A 60A																				
	NB Series 2-stage filter	High-attenuation		NBC: High-attenuation for low frequency band (150kHz to 1MHz) NBM: Low leakage current, Withstand voltage 4,000VAC NBH: Ultra high-attenuation and broadband (9kHz to 10MHz)	250VAC	6A 10A 16A 20A 30A																				
Three-phase EMI/EMC filter		JAC Series 1-stage filter	Compact and low profile	General purpose	High-attenuation for low frequency band (150kHz to 1MHz)	500VAC (528VAC)	6A 10A 20A 30A 40A 50A 60A																			
		TAC Series 1-stage filter			High-attenuation for low frequency band (150kHz to 1MHz)	500VAC (528VAC)	4A 6A 10A 20A 30A 50A 60A 80A 100A 150A 200A 250A 300A																			
		TAH Series 1-stage filter	Low profile	Ultra high-attenuation for ultra low frequency band (9kHz to 10MHz)	500VAC (528VAC)	4A 6A 10A 20A 30A 50A 60A 80A 100A 150A																				
		TBC Series 2-stage filter	High-attenuation	High-attenuation for low frequency band (150kHz to 1MHz)	500VAC (528VAC)	50A 60A 80A 100A 150A 200A 250A 300A																				
		FTA Series 1-stage filter	Book type (Space-saving type)	General purpose	High-attenuation for low frequency band (150kHz to 1MHz)	500VAC (528VAC)	40A 50A 60A 80A 100A 125A 150A																			
		FTB Series 2-stage filter		High-attenuation	Ultra high-attenuation for low frequency band (150kHz to 1MHz)	500VAC (528VAC)	80A 100A 150A																			
		FSB Series 2-stage filter	Low profile	Saturation resistance type	EMI/EMC Filter for motor drive system (AC servo) Improve saturation resistance	500VAC (528VAC)	10A 20A 30A 40A 50A 60A 80A 100A 150A																			
		TSC Series multi-stage filter		Ultra high-attenuation	Ultra high-attenuation from 150kHz to 1MHz	500VAC (528VAC)	400A 600A																			
		TSD Series multi-stage filter	Saturation resistance type	Ultra high-attenuation from 150kHz to 1MHz	500VAC (528VAC)	400A 600A 800A 1000A																				
		YAC Series 1-stage filter	General purpose		High-attenuation for low frequency band (150kHz to 1MHz) 1-stage filter: 25A to 80A 2-stage filter: 120A to 300A	500/289VAC (528/305VAC)	25A 36A 64A 80A 120A 160A 200A 300A																			
DC EMI/EMC filter		SNA Series 1-stage filter	Ripple noise attenuation for switch mode power supplies		For ±V output power supply	DC±50V	1A 3A 6A																			
		SNR Series 1-stage filter			For +V output power supply (Peak load)	DC50V	10A																			

EMI/EMC Filter Selection Guide by Function

Refer to EMI/EMC filter selection flow chart for options.

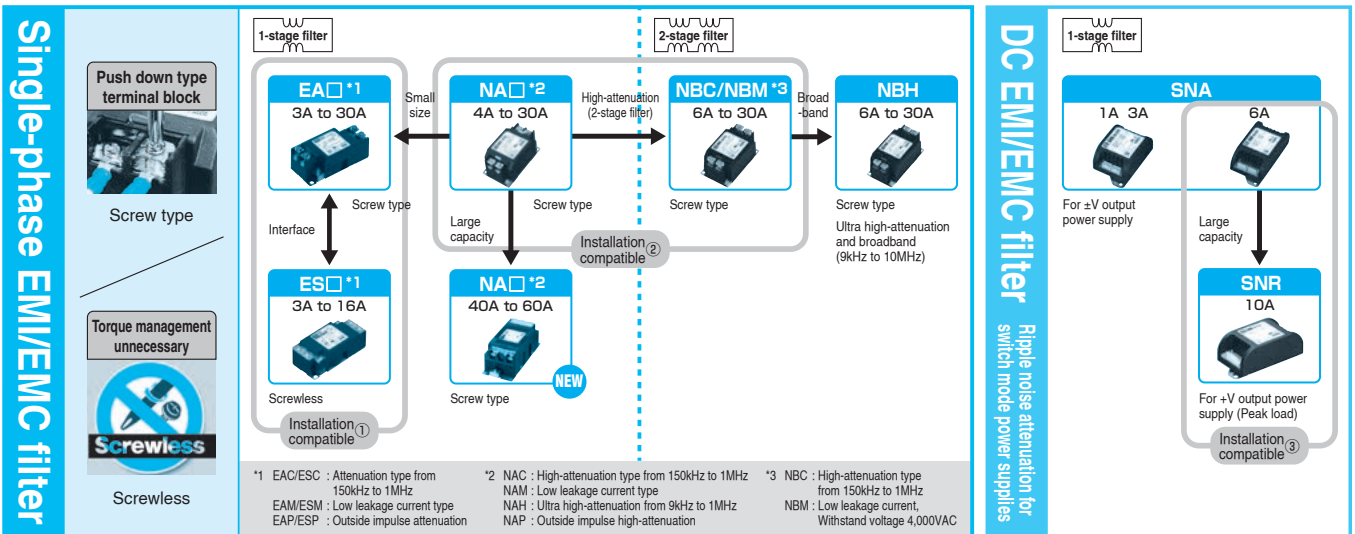
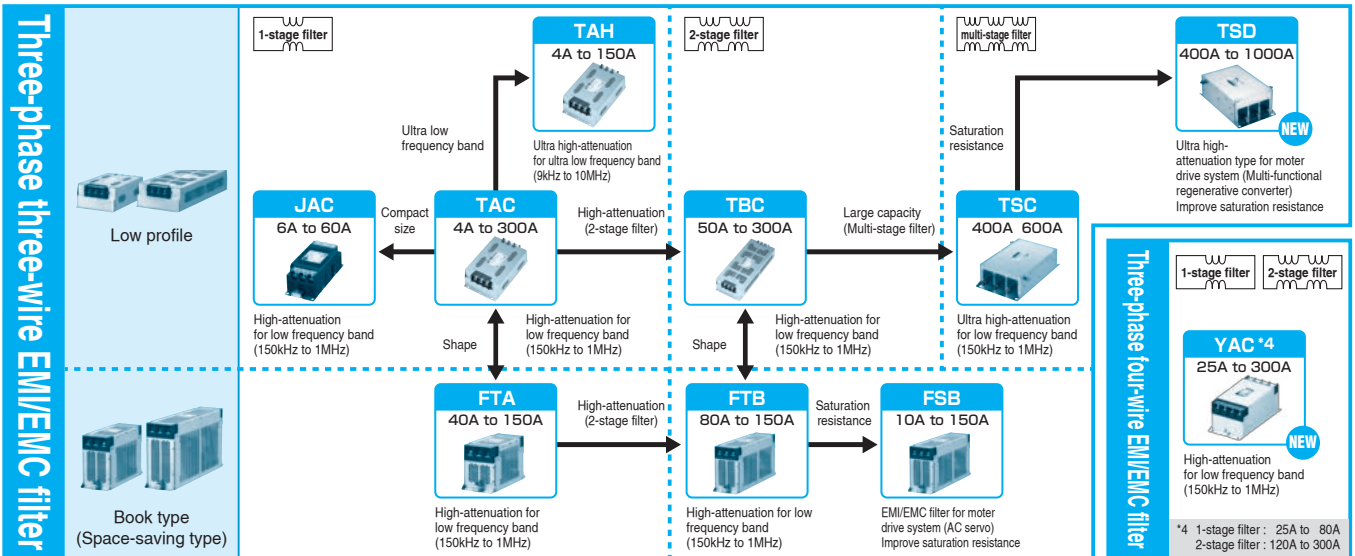
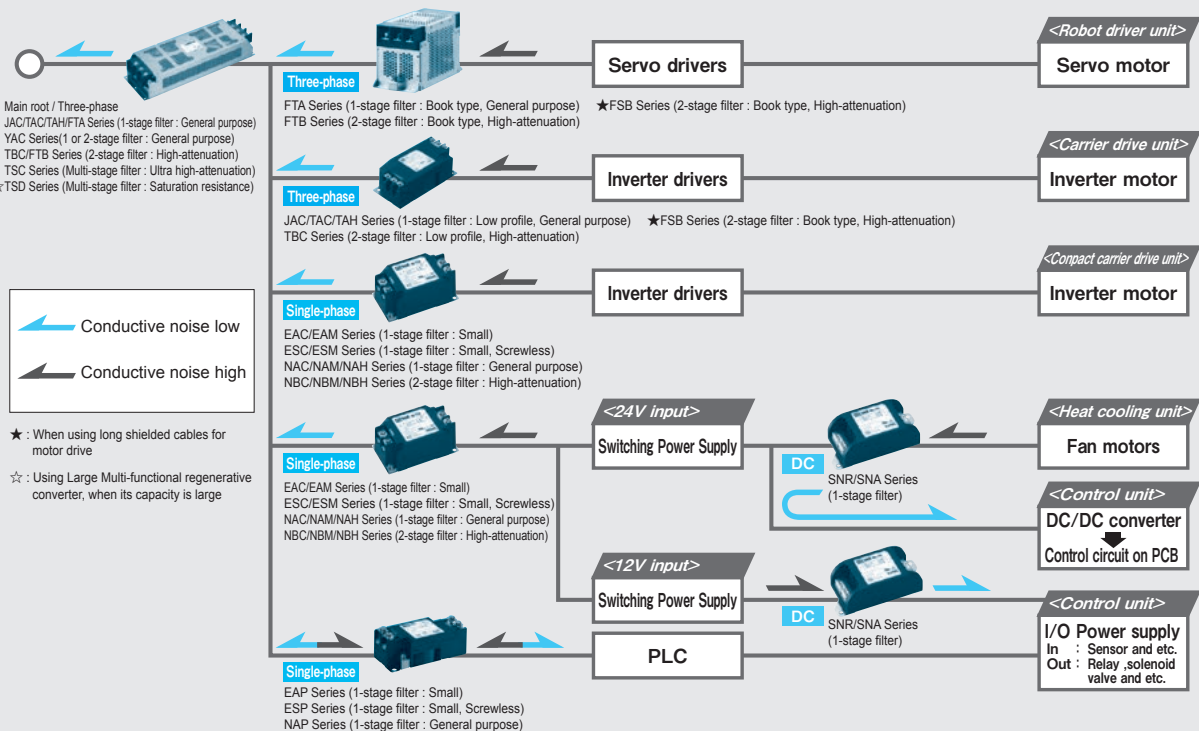

Diagram of Sample application



EMI/EMC Filter Selection flow chart

By using the flow chart below, you can easily select the model you need.

START

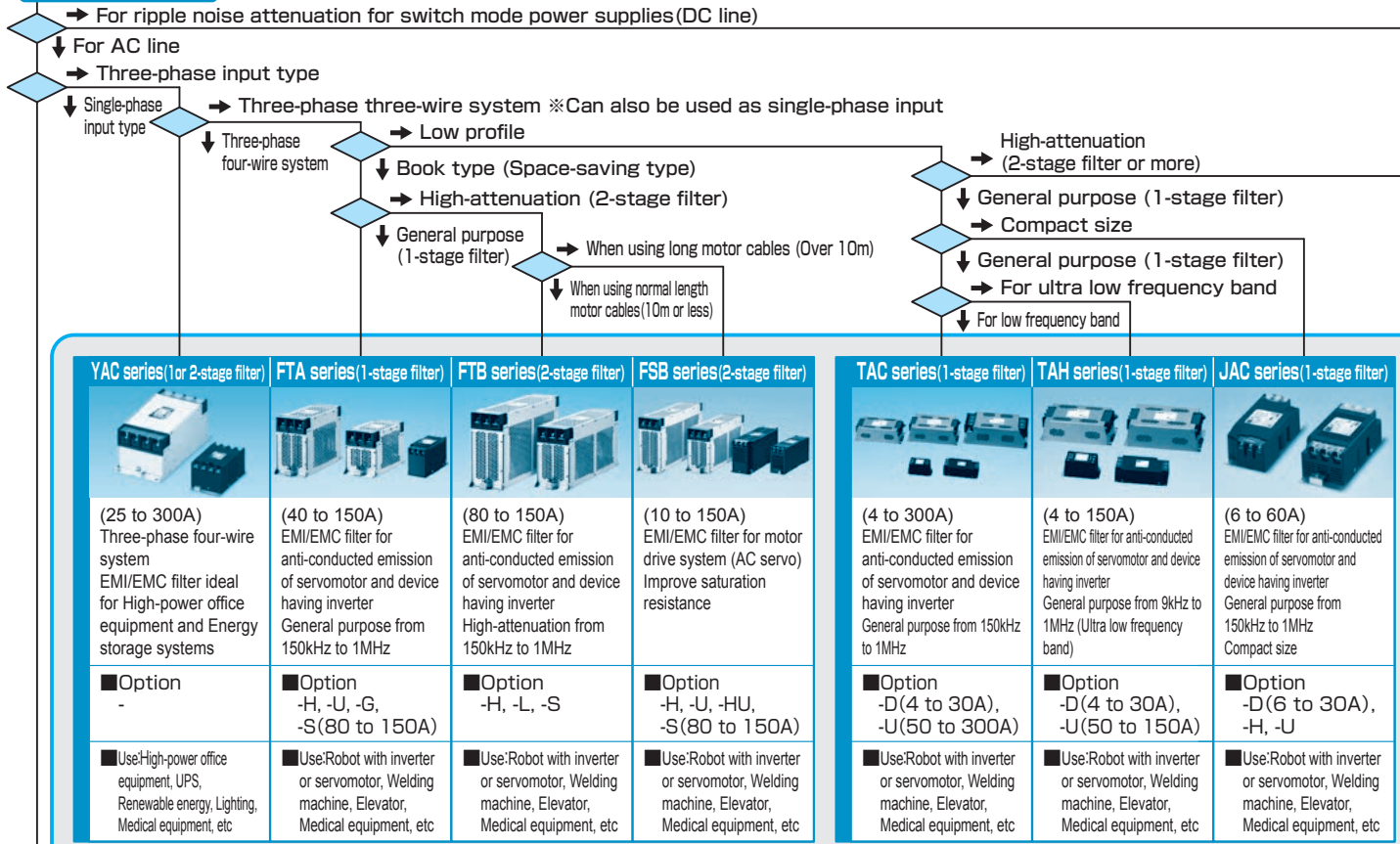

Three-phase EMI/EMC filter

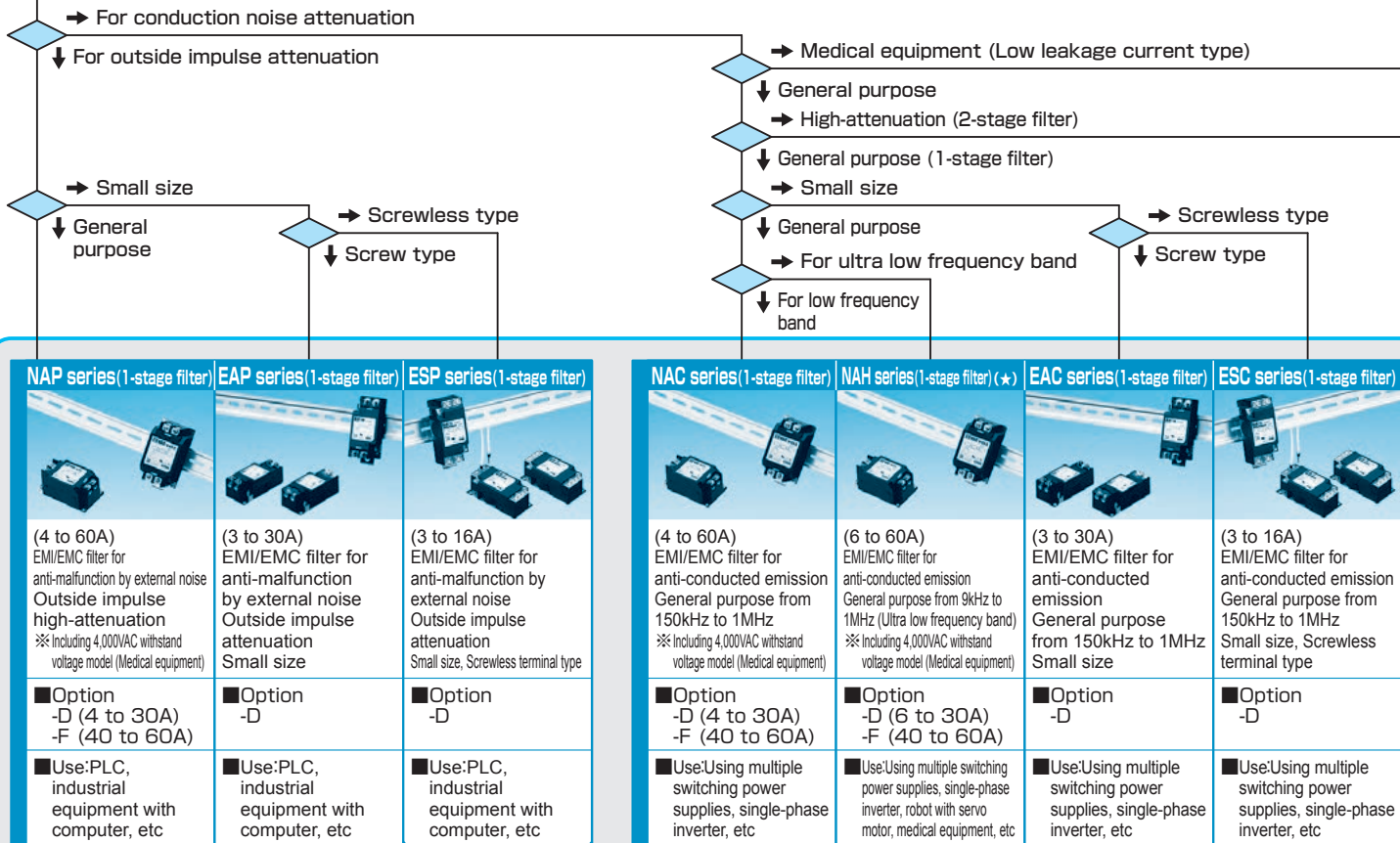

Single-phase EMI/EMC filter

■Option

- D : DIN rail installation type
- G : With switch of line to ground capacitor
- L : Ultra high-attenuation type for EU
- T : Terminal block type

- F : High input voltage (Rated voltage 500VAC/600VDC)
- H : Ultra high-attenuation type
- S : Hexagon socket head cap screw (Standard type is Hexagon head screw)
- U : Improve differential mode attenuation (Rated voltage 250V)

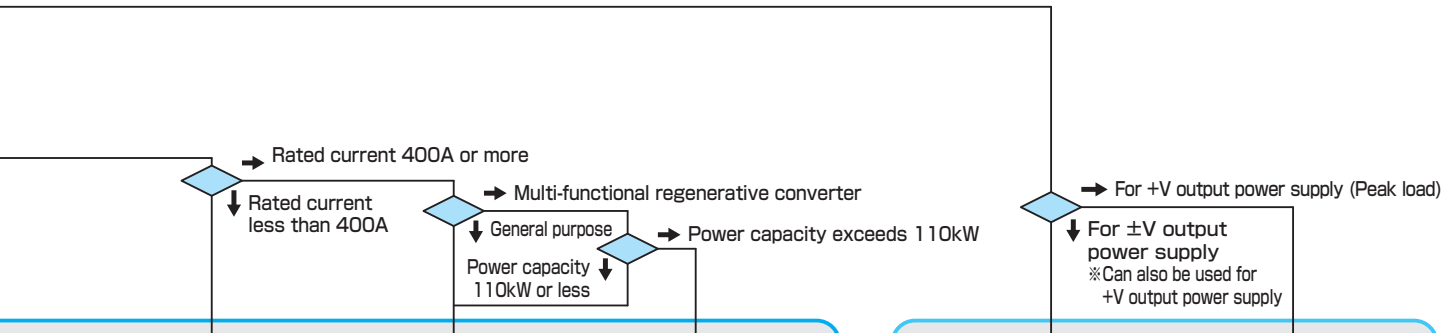

TBC series(2-stage filter)	TSC series(multi-stage filter)	TSO series(multi-stage filter)
(50 to 300A) EMI/EMC filter for anti-conducted emission of servomotor and device having inverter High-attenuation from 150kHz to 1MHz	(400, 600A) EMI/EMC filter for anti-conducted emission of servomotor and device having inverter Ultra high-attenuation from 150kHz to 1MHz	(400 to 1000A) Ultra high-attenuation for motor drive system (Multi-functional regenerative converter) Improve saturation resistance
■Option —	■Option ※1 -H	■Option ※1 —
■Use:Robot with inverter or servomotor, Welding machine, Elevator, Medical equipment, etc	■Use:Robot with inverter or servomotor, Welding machine, Elevator, Medical equipment, etc	■Use:Large equipment with Multi-functional regenerative converter (Transferred equipment, air conditioning equipment), etc

※1 Please contact us about low leakage current type (Change to low grounding capacitor)

SNA series(1-stage filter)	SNR series(1-stage filter)
(1, 3, 6A) Ripple noise attenuation for switch mode power supplies (DC+50V)	(10A) Ripple noise attenuation for switch mode power supplies (DC+50V)
■Option -D, -T(6A), -DT(6A)	■Option -D, -T, -DT
■Use:DC EMI/EMC filter for ±V output power supply of analog circuit (Operational amplifier etc.)	■Use:DC EMI/EMC filter for +V output power supply of analog circuit

DC EMI/EMC filter

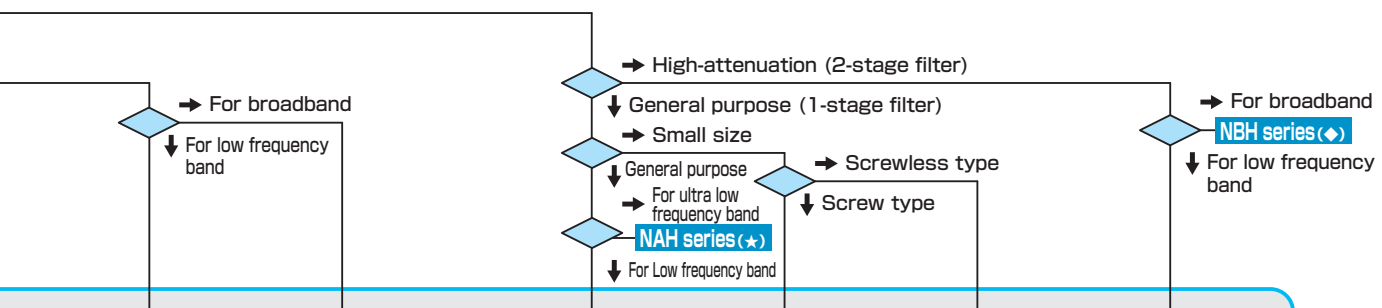

NBC series(2-stage filter)	NBH series(2-stage filter) (♦)	NAM series(1-stage filter)	EAM series(1-stage filter)	ESM series(1-stage filter)	NBM series(2-stage filter)
(6 to 30A) EMI/EMC filter for anti-conducted emission High-attenuation from 150kHz to 1MHz	(6 to 30A) EMI/EMC filter for anti-conducted emission Ultra high-attenuation and broadband from 9kHz to 10MHz ※Including 4,000VAC withstand voltage model (Medical equipment)	(4 to 60A) EMI/EMC filter for medical applications Low leakage current type General purpose from 150kHz to 1MHz ※Including 4,000VAC withstand voltage model	(3 to 30A) EMI/EMC filter for medical applications Low leakage current type General purpose from 150kHz to 1MHz Small size	(3 to 16A) EMI/EMC filter for medical applications Low leakage current type General purpose from 150kHz to 1MHz Small size, Screwless terminal type	(6 to 30A) EMI/EMC filter for medical applications Low leakage current type General purpose from 150kHz to 1MHz with stand voltage 4,000VAC
■Option -D	■Option -D	■Option -D (4 to 30A)	■Option -D	■Option -D	■Option -D
■Use:Using multiple switching power supplies, single-phase inverter, etc	■Use:Using multiple switching power supplies, single-phase inverter, robot with servo motor, medical equipment, etc	■Use:A case when using multiple switching power supplies, or for medical applications like endoscope, etc	■Use:A case when using multiple switching power supplies, or for medical applications like endoscope, etc	■Use:A case when using multiple switching power supplies, or for medical applications like endoscope, etc	■Use:A case when using multiple switching power supplies, or for medical applications like endoscope, etc

EMI Filter

1 Noise Basics

- 1 What Is Noise?
- 2 Noise Sources
- 3 What Is EMC?
- 4 Propagation Paths of Noise
 - a. Conductive noise
 - b. Inductive noise
 - c. Radiated noise
- 5 Basics of Noise Reduction
- 6 Types of Conductive Noise
- 7 Types of and Countermeasures for Noise
 - a. High-frequency noise
 - b. Pulse noise
 - c. Surge noise

2 Selection of EMI Filters

- 1 Rated Voltage
- 2 Rated Current
- 3 Test Voltage (Withstand Voltage)
- 4 Insulation Resistance (Isolation Resistance)
- 5 Leakage Current
- 6 DC Resistance
- 7 Temperature/Humidity
- 8 Circuitry
 - a. Single-phase one-stage filter
 - b. Single-phase two-stage filter
- 9 Safety Standards
 - a. Overview of safety standards
 - b. Safety standards for EMI filters
 - c. CCC approval from China
- 10 Attenuation Characteristic (Static Characteristic)
- 11 Pulse Attenuation Characteristic
- 12 Ground Capacitor Codes
- 13 Options
 - a. DIN rail installation type
 - b. Terminal block type
 - c. High permeability choke coil type
 - d. Hexagon socket head cap bolt type
 - e. With switch of line to ground capacitor type
 - f. Improve differential mode attenuation type
 - g. Ultra high attenuation type for EU
 - h. High input voltage type

3 How to Use EMI Filters

- 1 Ground Wiring
- 2 Input and Output Wiring

4 Noise Reduction

- 1 Input and Output Impedance and Filter Circuit
- 2 EMI Filter Installation and Orientation
- 3 Combining Multiple EMI Filters
- 4 External Ferrite Core

5 EMC Test

- 1 CE Marking
 - a. Machinery directive
 - b. EMC directive
 - c. Low voltage directive
- 2 Conducted Emission
- 3 Radiated Emission
- 4 Power Supply Harmonic Current
- 5 Electrostatic Discharge
- 6 Radio frequency electromagnetic field
- 7 Fast Transient/Burst
- 8 Surge
- 9 Conducted Radio-frequency Interference
- 10 Power Frequency Magnetic Field
- 11 Voltage Dip/Momentary Power Interruption
- 12 Unit of Noise
- 13 Detection Method
 - a. Peak detection
 - b. Quasi-peak detection
 - c. Average detection
- 14 Noise Terminal Voltages, Radiated Emission Limits (Extractions)
- 15 Terminology related to EMC Test

6 Supplement

- 1 Source Voltages in the World

1 Noise Basics

1 What Is Noise?

Noises refers to unwanted variations or fluctuations in voltage, current, signals, etc.

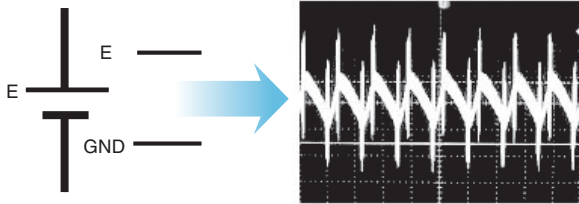

What a designer expects (an ideal steady voltage source)

In reality, noises are included.

Figure 1.1.1 What Is Noise?

2 Noise Sources

Noise comes in two types: natural noise and manmade noise. While natural noises are generated by a lightning strike or static electricity, manmade noises are generated by familiar devices such as industrial equipment, fluorescent bulbs, or communication equipment.

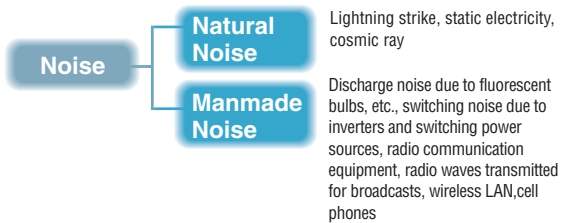

Figure 1.2.1 Noise Sources

Typical devices that generate noise are switching power sources and general-purpose inverters. Such devices include switching elements such as FETs and IGBTs, and are major noise sources due to high-frequency switching of those elements.

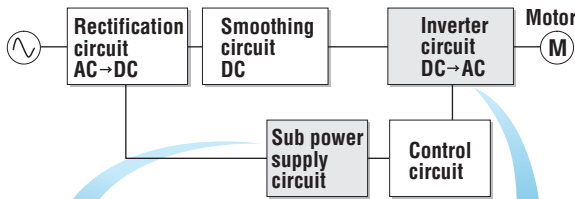

Figure 1.2.2 Inverter block diagram

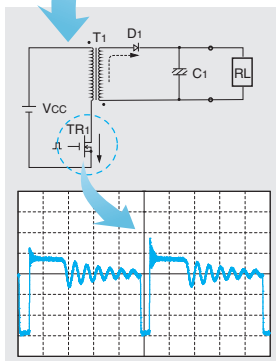

Figure 1.2.3 Sub power supply inverter operation waveform

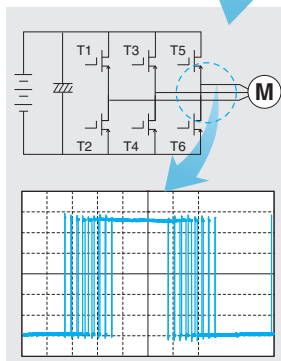

Figure 1.2.4 Inverter PWM output waveform

3 What Is EMC?

EMC stands for electromagnetic compatibility, and refers to the ability of electrical equipment to have both EMI and EMS at once; the former indicates the ability to suppress noise radiated from the equipment itself and the latter means the ability to endure noise from other equipment.

What are EMC compliant products?

The EMC compliant products refer to those that meet standards required by EMI and EMS.

They provide various types of parts that can deal with noise from the viewpoint of EMI and/or EMS.

Our noise filters (hereinafter, "EMI filters") are parts that mainly deal with conducted interference in terms of EMI.

$$EMC = EMI + EMS$$

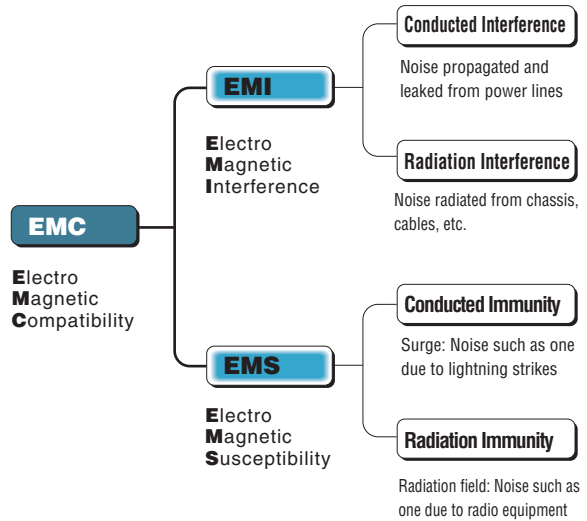

Figure 1.3.1 Concept of EMC

1 Noise Basics

4 Propagation Paths of Noise

a. Conductive noise

Refers to noise that propagates through a power line or PCB tracing.

b. Inductive noise

Refers to noise that is induced due to electromagnetic or electrostatic induction caused by a power line or a signal line of a peripheral device when it is placed near a line or pattern in which noise current flows and propagates through the line.

c. Radiated noise

Noise radiated by an antenna (or a line be having as an antenna) that propagates to other devices through the air.

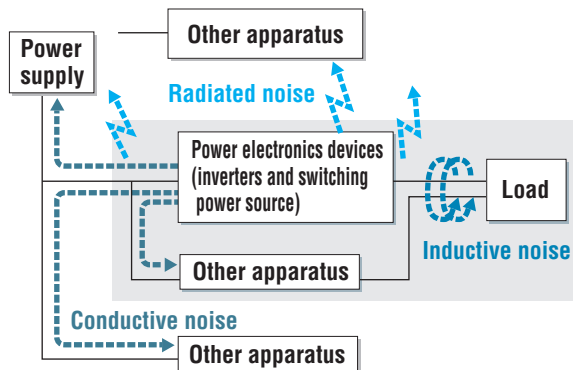

Figure 1.4.1 Propagation Paths of Noise

5 Basics of Noise Reduction

The propagation of noise consists of a noise source, an entity that is affected by the noise, and propagation path that connects both. To reduce noise:

- Reduce the noise level of a noise source
- Make it more difficult for noise to propagate
- Make equipment less vulnerable to noise

In addition to the above, designs must consider standards, quality and cost of noise reduction methods.



Figure 1.5.1 Overview of Noise Generation and Propagation Path

6 Types of Conductive Noise

Noise is divided into two types based on its generation mode: normal mode noise and common mode noise. Normal mode noise is also called differential mode noise, and refers to noise generated between power lines. Common mode noise refers to noise generated between a power line and ground line.

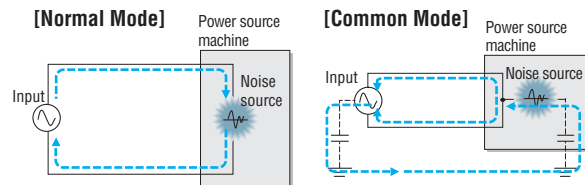
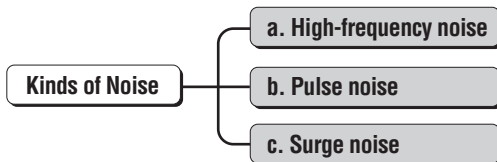

Figure 1.6.1 Noise Generation Paths (Example in which a noise source is within power equipment)

7 Types of and Countermeasures for Noise



a. High-frequency noise

Also called EMI noise or power supply noise and refers to high-frequency components such as the clock frequency of a computer and switching frequency of power sources. As an antinoise measure, an EMI filter should be installed on the input side. An appropriate filter should be selected based on requirements such as attenuation, mechanical design and cost.

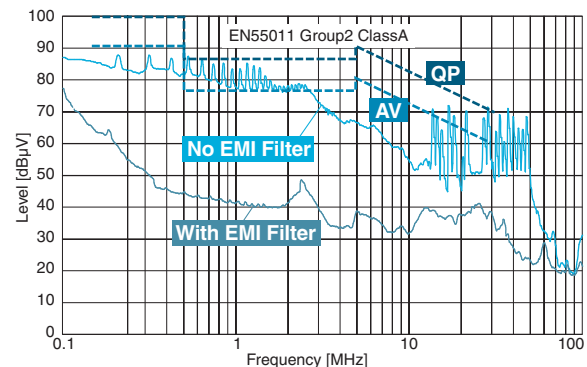
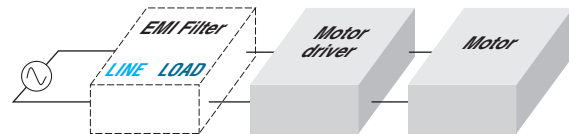

Figure 1.7.1 Example of Noise Reduction by an EMI Filter

1 Noise Basics

Output ripple noise from a switching power source is also a type of high-frequency noise.

Ripple noise can be reduced with a DC filter designed for it.

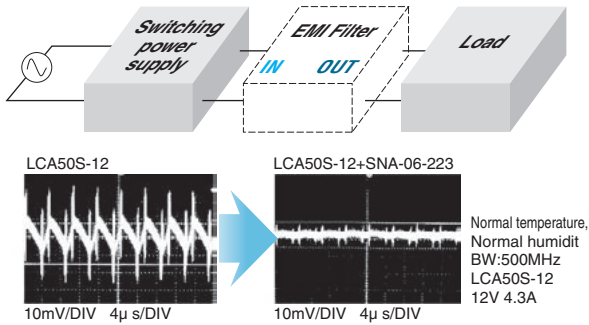

Figure 1.7.2 Example of Effectiveness of Ripple Noise Filter

b. Pulse noise

This noise is generated when a relay or motor is driven. As peak voltage may reach as high as a few thousand volts, generic filters may not be able to sufficiently attenuate noise because its choke coil gets saturated. As an antinoise measure, one could select a filter that uses an amorphous core for its superior pulse attenuation characteristic.

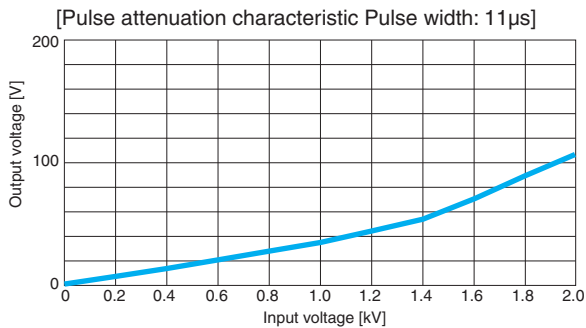
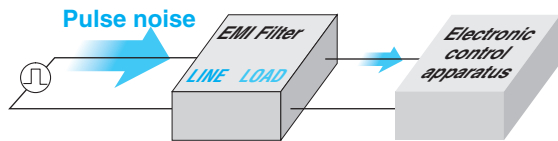

Figure 1.7.3 Example of Pulse Attenuation Characteristic(NAP-16-472)

c. Surge noise

This noise occurs when a natural discharge (such as lightning) affects a power line. As the generated voltage reaches as extremely high as a few kilovolts or more, EMI filters cannot suppress surge noise. As an antinoise measure, one could use a part such as a varistor to control surge voltage between power lines or between a power line and ground. EMI filters can withstand approximately 2 kV between power lines and approximately 4 kV between a power line and ground (these values are not guaranteed).

If surges are a concern, surge countermeasures should be selected and installed to handle the EMI filter's capabilities.

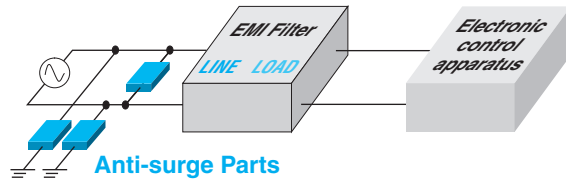

Figure 1.7.4 Proper Installation Location of surge Countermeasures

2 Selection of EMI Filters

1 Rated Voltage

The rated voltage is the maximum line voltage (nominal value) allowable to be used.

As the rated voltages for some parts used within an EMI filter are high in reality, however, voltages higher than the rated voltage of the EMI filter may be used without causing any trouble.

In fact, the rated voltages of filter components are often higher, in which case the filter can handle actual voltages that exceed its ratings.

In the case of some EMI filters, the maximum operation voltages are defined by specifications for them, separately from rated voltages.

Note that using EMI filters at voltages lower than their rated voltages do not pose any problems. For example, an EMI filter with a rated voltage of AC 250 V can be used for power lines of AC 100V.

As for line frequency, EMI filters for AC power supply lines have been basically designed to be used with the commercial frequency (50 Hz/60 Hz).

Higher frequencies such as 400Hz can cause problems such as excessive capacitor heating.

Note that EMI filters for AC power lines can also be used for DC power supply lines.

2 Rated Current

The rated current is the maximum load current (nominal value) that can be continuously carried. If the ambient temperature is high, however, the load current needs to be derated.

Figure 2.2.1 shows an example of a derating characteristic.

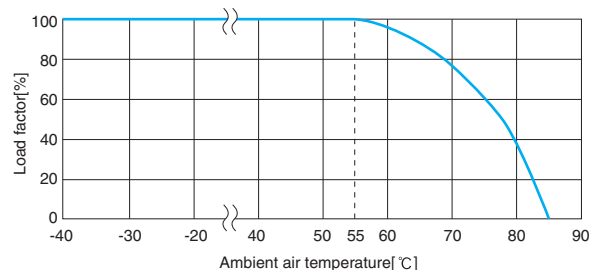

Figure 2.2.1 Derating Curve

This example indicates that when the maximum ambient temperature reaches 75, the EMI filter should be used with a load factor of approximately 60% (approximately 60% of the rated current) or lower.

Current higher than the rated current would be allowed to flow in EMI filters for a short period of time only. Inrush current (Up to 40A or 10 times the rated current, single shots with a length of a few milliseconds) from devices such as a general switching power source does not cause any problems, but relatively long and / or repetitive peak current draws can result in the average current exceeding the filter's rating.

3 Test Voltage (Withstand Voltage)

The test voltage is a voltage value that is applied at the time of withstand voltage test. The withstand voltage test is to verify that the part does not break when applying a high voltage in a short period of time between a terminal (line) and the mounting plate (ground) of an EMI filter.

In the case of EMI filters for AC power lines, the test voltage is generally AC 2000 V or AC 2500 V.

In withstand voltage tests, the high voltage applied between a line and ground, results in abnormally high leakage current flow. When carrying out a withstand voltage test in an acceptance inspection, please set the cutoff current of withstand voltage test equipment to an appropriate value (the cutoff current defined in the specifications for the EMI filter).

For some EMI filters that have ground capacitors with extremely large capacity, DC voltages may be used for test voltages because the leakage current becomes too high when AC voltages are applied.

4 Insulation Resistance (Isolation Resistance)

Insulation resistance is a resistance value when applying a specified DC voltage (normally 500 V) between isolated conductors such as a terminal (line) and the mounting plate (ground), and regarded as one indicator of degree of insulation.

The insulation resistance is found by measuring the very small current that flows in an insulating material such as a resin case and capacitor when DC voltage is applied.

5 Leakage Current

The leakage current is an electric current that flows from the ground terminal of an EMI filter when the filter is connected to an AC power line.

Generally, as one sets the capacitance of a ground capacitor to a higher value, the reduction effect on common mode noise will be heightened and at the same time, the leakage current will increase.

Care must be taken, because large leakage current could cause a circuit breaker to trip or electric shock to occur when the EMI filter is not properly grounded.

Current (I) that flows from each power line to ground is represented with the following expression; it forms the basis of leakage current calculation.

$$I = 2 \pi f C E$$

f : Power frequency
 C : Capacitance between line and ground
 E : Power supply voltage between line and ground

2 Selection of EMI Filters

6 DC Resistance

DC resistance is a resistance value between the input and output of an EMI filter (the sum of resistance values for both directions).

It is mostly accounted for with the coil resistances but also includes connections between the coils and terminals.

The voltage drop caused by an EMI filter is represented with the following expression:

$$\text{Voltage drop} = \text{DC resistance} \times \text{Load current}$$

Note that specifications for some products define voltage drops when rated current is carried, instead of resistance values.

7 Temperature/Humidity

a. Operating temperature

This is the range of ambient temperatures for which the product's usage is guaranteed.

If an ambient temperature is high, the load current needs to be derated.

b. Operating humidity

This is the range of ambient humidities for which the product's usage is guaranteed.

It assumes no condensation.

c. Storage temperature and humidity

The specified ranges of ambient temperatures and humidities that EMI filters in an unenergized state can be stored without deteriorating performance. No condensation is assumed for the storage humidity.

8 Circuitry

The following represents examples of EMI filter circuit structures.

a. Single-phase 1-stage filter

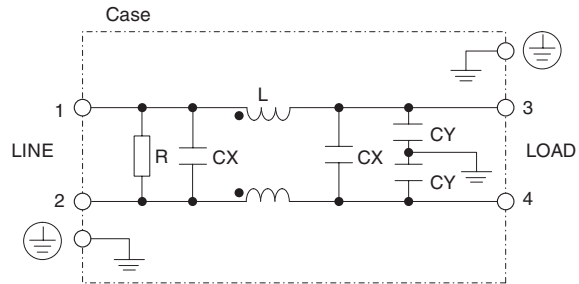

Figure 2.8.1 Circuit Structure Example of a Single-phase 1-stage EMI Filter

This figure shows a standard circuit structure for single-phase EMI filters.

L and CYs reduce the common mode noise; CXs and leakage inductance from L reduce the normal mode noise.

R indicates a discharge resistance for capacitors.

b. Single-phase 2-stage EMI filter

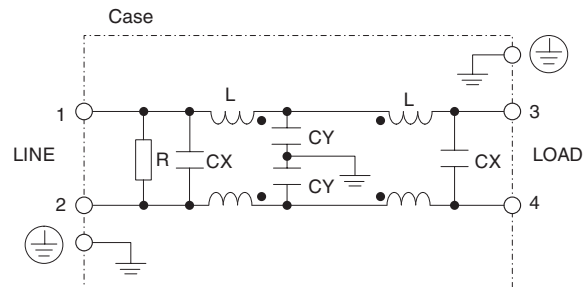

Figure 2.8.2 Circuit Structure Example of a Single-phase 2-stage EMI filter

The above figure represents a circuit structure example of placing choke coils in two stages to improve the attenuation characteristic.

The following graph shows an example comparison of attenuation characteristics for a 1-stage and 2-stage EMI filter.

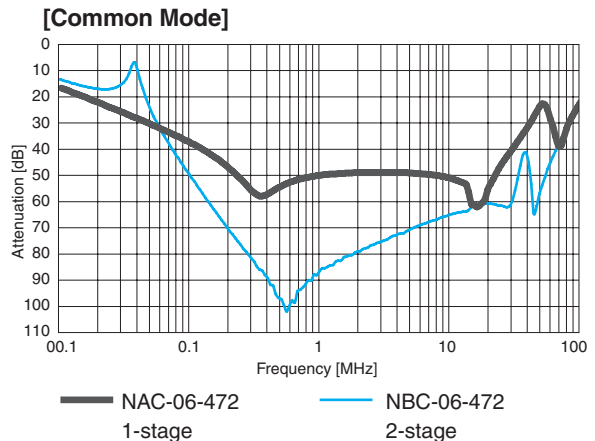

Figure 2.8.3 Example of Comparing Attenuation Characteristics between 1-stage and 2-stage EMI filters.

2 Selection of EMI Filters

9 Safety Standards

a. General description of safety standards

The international standards consist of IEC standards which concern the electrical fields, and ISO standards which concern the non-electrical fields.

IEC

(International Electrotechnical Commission)

Standardization organization for standards related to the electrical fields; its headquarters is located in Switzerland.

It releases technical standards for electricity based on the latest sciences and technologies, and each country develops its own specific safety standards based on the corresponding IEC standards.

CISPR

(Comite International Special des

Perturbations Radioelectriques

=International Special Committee

on Radio Interference)

One of IEC's special committees; it was established with the aim to integrate standards such as allowable values and measurement methods for interfering waves causing radio communication failures, and includes a standardization committee for EMC (Electro Magnetic Compatibility).

European Standard / EN Standard





(Europäische Norm=European Standard)

The EN Standard was created based on the IEC and CISPR standards, and consists of items almost similar to those in both standards.

A unique number is assigned to each standard.

(Example: IEC939 EN60939)

[An example of Certification Authorities in Europe based on EN Standard]

VDE	Germany	
TUV	Germany	
DEMKO	Denmark	
SEMKO	Sweden	

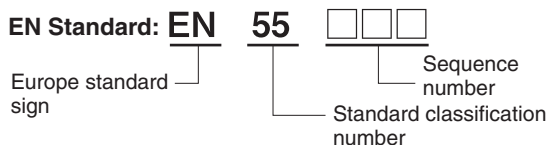

Standard classification number	Reference standards
EN50000 series	General European standards
EN55000 series	CISPR standards
EN60000 series	IEC standards

ENEC



(European Norm Electrical Certification)

The safety approval mark in Europe that enables products to smoothly be delivered among all the EU signatories, EFTA (European Free Trade Area), and East European countries.

Electronic products that are authorized to bear the ENEC mark do not need to be subjected to application procedures among the signatories. It provides a benefit of eliminating the need to obtain approval from each signatory to which they are distributed. The ENEC mark is intended to apply to products such as lighting equipment, transformers, information processing equipment, switches and EMI filters.

★ EU signatories... Germany, UK, Italy, Denmark, and 24 other countries

★ EFTA... Iceland, Norway, Switzerland, and Lichtenstein

★ East European... Ukraine, Estonia, Belorussia, Moldova, Latvia, and Lithuania

North America

UL (Underwriters Laboratories Inc.)

A test organization established in 1894 by the Electrical Bureau of the National Board of Fire Underwriters. Since then, it has been performing compliance tests on various electric products.

CSA (Canadian Standard Association)

A non-profit standardization organization established in Canada in 1919. Each state law in Canada requires that electric equipment that needs to be connected to a public power source conforms to the CSA standards.

UL	USA	
CSA	Canada	

As the US and Canada have signed MRA (Mutual Recognition Agreement), mutual approval can be obtained. If UL verifies that a certain electric product conforms to the CSA standard, or to the UL and CAS standards, the product is authorized to bear the following approval marks:

CSA	
UL, CSA	

b. Safety standards for EMI filters

Different products may conform to different safety standards and bear different approval marks (for use in different countries). Check the approved safety standards when considering purchasing them.

IEC939	International standard	IEC
EN60939	EU	EN
UL1283	USA	UL
C22.2 No.8	Canada	CSA

c. CCC approval from China

EMI filters do not fall within the scope of CCC. (as of November 2011)

2 Selection of EMI Filters

10 Attenuation Characteristic (Static Characteristic)

Attenuation characteristic provides a rough indication of noise reduction effect. The graph is derived from plotting an attenuation characteristic when connecting a EMI filter to a specified measurement circuit with frequency on the horizontal axis and with attenuation on the vertical axis.

The measurement methods are shown in Figure 2.10.1 and Figure 2.10.2. The attenuation is given as the ratio of U_{01} to U_{02} , where U_{01} is output when EMI filters are not in the measured circuit and U_{02} is when an EMI filter is in the circuit, and normally expressed with the logarithm of that ratio in [dB].

$$\text{Attenuation} = 20\text{Log}_{10} (U_{01}/U_{02}) \text{ [dB]}$$

U_{01} :Generated voltage when a EMI filter is not inserted [V]

U_{02} :Generated voltage when a EMI filter is inserted [V]

*An attenuation of 20 [dB] means that the noise level reduces to 1/10 of the one without an EMI filter. Similarly, 40 [dB] and 60 [dB] mean a 1/100 and 1/1000 reduction of the noise level, respectively.

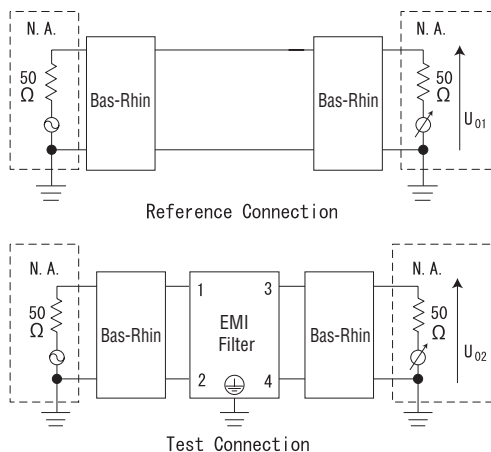

Figure 2.10.1 Attenuation Characteristic Measurement Method (Single-phase Normal Mode)

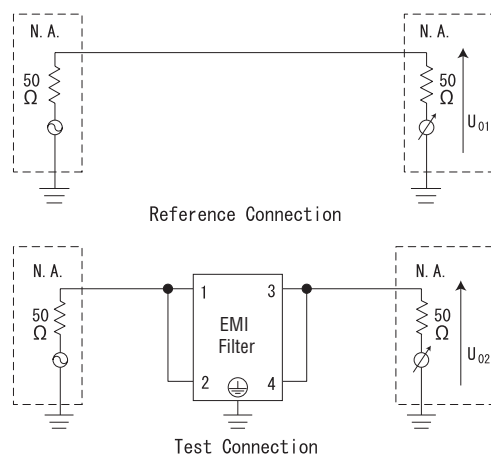

Figure 2.10.2 Attenuation Characteristic Measurement Method (Single-phase Common Mode)

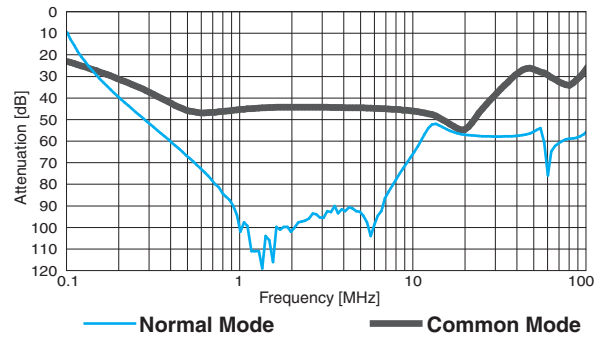

Figure 2.10.3 Example of Attenuation Characteristic (NAC-16-472)

The attenuation characteristic of EMI filters is affected by the input and output impedances of a measured circuit. This attenuation characteristic (static characteristic) is measured under the constant condition of input and output impedances of 50 Ω regardless of measurement frequencies. This enables the attenuation characteristics of different filters to be compared under the same conditions.

However, actual electronic devices have different power line impedances, and impedance itself has its own frequency characteristic and does not take a constant value.

For these reasons, the attenuation characteristics (static characteristics) that are specified in the catalogs for EMI filters do not necessarily coincide with those when they are attached to actual electronic devices.

One must also be careful that when connecting EMI filters in series, the static characteristic of the resultant series is not derived from simply adding the static characteristics [dB] of the individual filters.

11 Pulse Attenuation Characteristic

Figure 2.11.2 represents how much the EMI filter can attenuate pulse common mode noises, which may cause malfunctions of electronic equipment, connected to a power line. Figure 2.11.1 illustrates the measurement method.

When terminating the input and output of the EMI filter with 50 Ω , and applying a specified pulse waveform on the input, pulse voltages appearing on the output are measured and plotted with the horizontal axis representing input pulse voltage and with the vertical axis representing output pulse voltage.

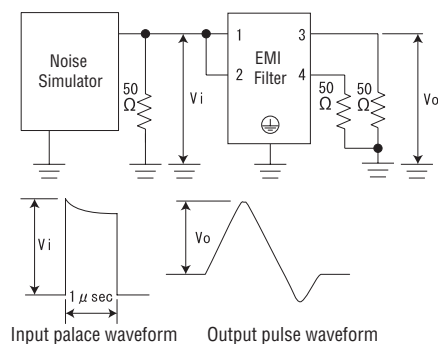

Figure 2.11.1 Measurement Method for Pulse Attenuation Characteristic (Single Phase)

2 Selection of EMI Filters

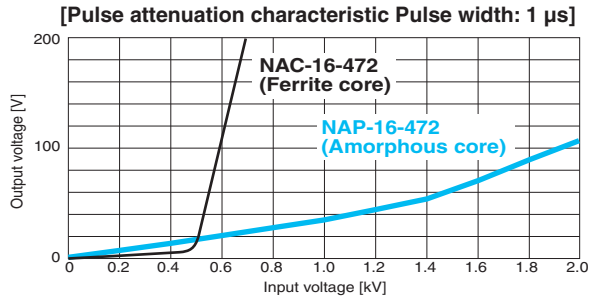

Figure 2.11.2 Example of Comparing Pulse Attenuation Characteristics

Figure 2.11.2 gives an example of comparing pulse attenuation characteristics for an EMI filter using a general ferrite core and one using an amorphous core.

The graph suggests that the amorphous core prevents the voltage of output pulses from increasing quickly in relation to rising input pulse voltage (a good pulse attenuation characteristic).

Beyond a given volt-time product the choke coil of an EMI filter will saturate, resulting in significantly reduced noise suppression. The volt-time product (V·T) that causes the core to reach magnetic saturation is found with the following calculation expression:

$$V \cdot T = \Delta B \cdot N \cdot Ae$$

V : Pulse voltage [V]
T : Pulse width [sec]
ΔB : Change of core's magnetic flux density = $B_m - B_r$ [T]
B_m : Saturation magnetic flux density
B_r : Residual magnetic flux density
N : Number of turns in a coil [turns]
A_e : Effective cross section [m²]

According to the expression, an EMI filter using a core that has larger ΔB (for example, an amorphous core) is less vulnerable to magnetic saturation, assuming that the numbers of turns and the sizes of cores are the same.

12 Ground Capacitor Codes

Many EMI filters can support various capacities of ground capacitors by specifying an appropriate code. The selectable ground capacitor codes depend on the types of EMI filters; the following table lists an example of ground capacitor codes and attenuation characteristics.

Table 2.12.1 Example of Ground Capacitor Codes (EAP series)

Code	Leak Current (input 125/250V 60Hz)	Line to ground capacitor (nominal value)
000	5 μA / 10 μA max	Not Provided
101	12.5 μA / 25 μA max	100pF
221	25 μA / 50 μA max	220pF
331	37.5 μA / 75 μA max	330pF
471	50 μA / 100 μA max	470pF
681	75.5 μA / 150 μA max	680pF
102	0.13 mA / 0.25 mA max	1000pF
222	0.25 mA / 0.5 mA max	2200pF
332	0.38 mA / 0.75 mA max	3300pF
472	0.5 mA / 1.0 mA max	4700pF

EAP -10 -472 -□
 Model Name | Rated Current | Ground Capacitor Codes | Option

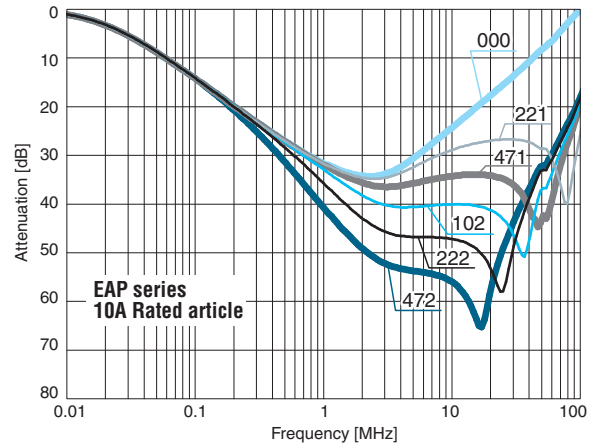

Figure 2.12.1 Example of Ground Capacitor Codes and Common Attenuation Characteristics

Generally, the larger capacity one sets a ground capacitor to, the better the common mode attenuation characteristic. But, the leakage current will also become larger, which means that there is a tradeoff.

The abundant selections of ground capacitor capacities make it possible for one to develop the best balance between attenuation characteristic and leakage current.

13 Options

Our EMI filters can be customized by specifying an option code.

As the types of set options depend on filter products, please refer to our catalog.

The following describes the outline of each option:

a. DIN rail installation type: D

This type of EMI filter can be installed to a DIN rail often used for control consoles, etc.

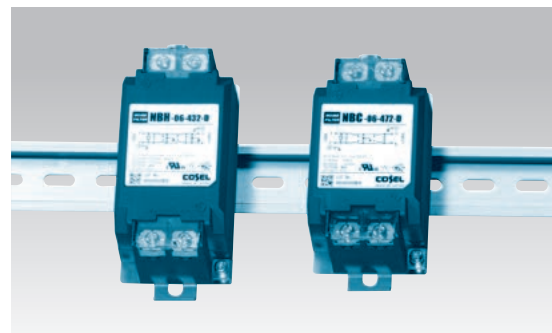

Figure 2.13.1 Examples of DIN Rail Installation Type EMI Filters

Note that as this type of EMI filter may not produce proper noise attenuation with grounding through a DIN rail, one must connect the ground to the protective earth terminal (PE) of the EMI filter. For EMI filters that have two protective earth terminals, it can connect the ground to either one only.

2 Selection of EMI Filters

b. Terminal block type: T

These types of EMI filters use a terminal block as their interface (if the standard product uses a connector).

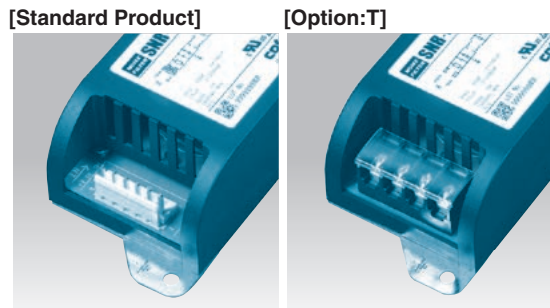

Figure 2.13.2 Comparison between Standard Product and T-option Product

c. High permeability choke coil type (ultra low-frequency and ultra high attenuation): H

These types of EMI filters the choke coil core with a high permeability core. These types improve the common mode attenuation characteristic for low frequencies compared to their standard products.

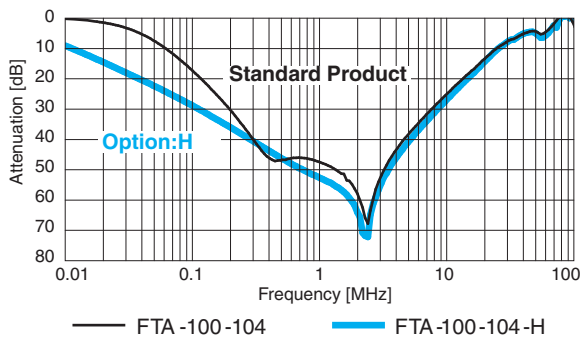

Figure 2.13.3 Example of Comparing Common Mode Attenuation Characteristics between Standard Product and H-option Product

d. Hexagon socket head cap bolt type: S

These types of EMI filters have a hexagon socket head cap (Allen) bolt in their terminal block in instead of the standard bolt (cross recessed (Philips) hexagon head bolt). Customers can select the desired type of bolt for tools they are using.

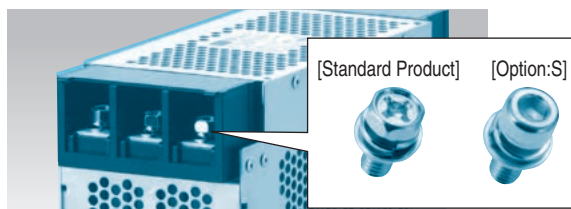

Figure 2.13.4 Comparison between Standard Product and S-option Product

e. With switch of line to ground capacitor type : G

These types of Ultra high attenuation type for EU, With switch of line to ground capacitor.

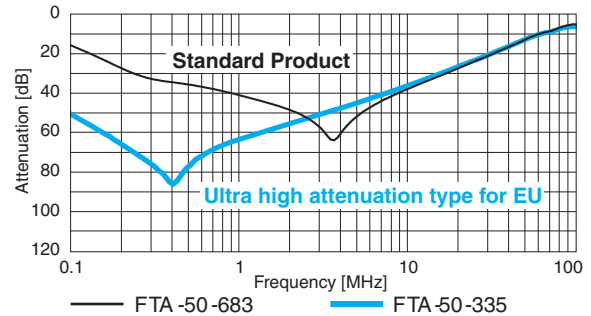

Figure 2.13.5 Example of Comparing Common Mode Attenuation Characteristics between Standard Product and Ultra high attenuation type for EU Product



Figure 2.13.6 With switch of line to ground capacitor type (Customers use when Test Voltage)

f. Improve differential mode attenuation type : U

These types of change the rated voltage 250V.

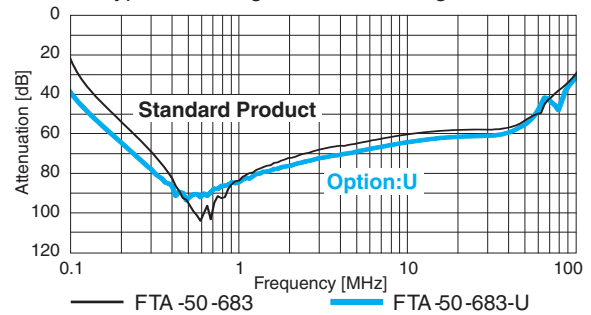

Figure 2.13.7 Example of Comparing differential Mode Attenuation Characteristics between Standard Product and U-option Product

g. Ultra high attenuation type for EU : L

These types of Ultra high attenuation type for EU.

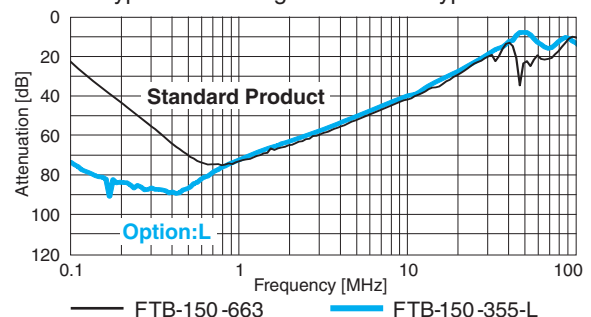

Figure 2.13.8 Example of Comparing Common Mode Attenuation Characteristics between Standard Product and L-option Product

h. High input voltage : F

These types of change the rated voltage 500VAC/600VDC.

Option code is possible combination. Please contact us for more information.

3 How to Use EMI Filters

1 Ground Wiring

When wiring an EMI filter with a ground wire, use a wire as thick and short as possible. A long ground wire will deteriorate attenuation of high frequencies due to inductance in the wire.

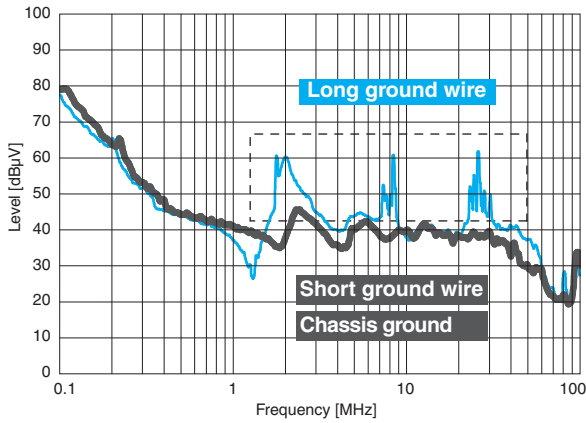

Figure 3.1.1 Example of Ground wiring Effed on Noise

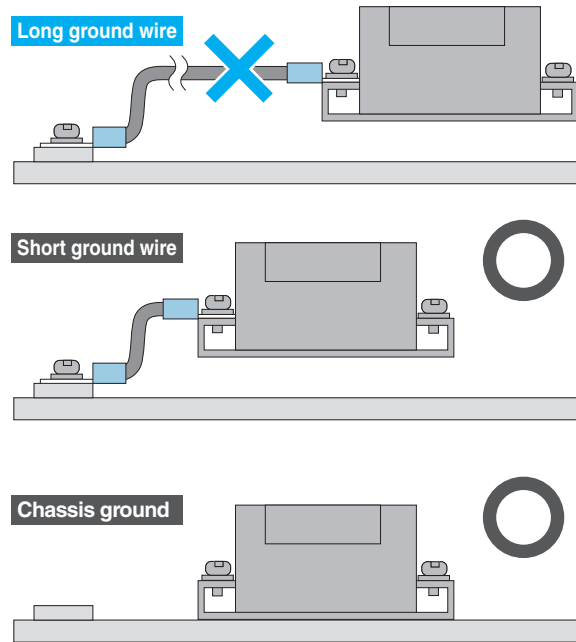

Figure 3.1.2 Proper grounding

If customers connect the metal chassis of their EMI filter, they can obtain an effect similar to a short ground wire.

2 Input and Output Wiring

Separate input wires from output wires. If one binds input and output wires of EMI filters, or lays them close to each other, the filters may lose their proper attenuation effect because the high-frequency noise component may bypass them. Twisting input (and / or output) wires in pairs can reduce noise.

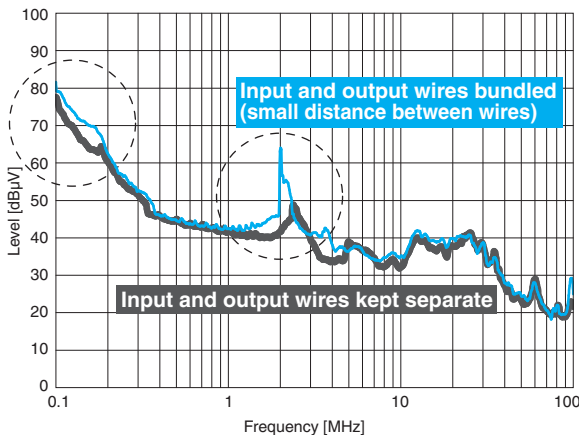

Figure 3.2.1 Example of Effect of wiring on Noise

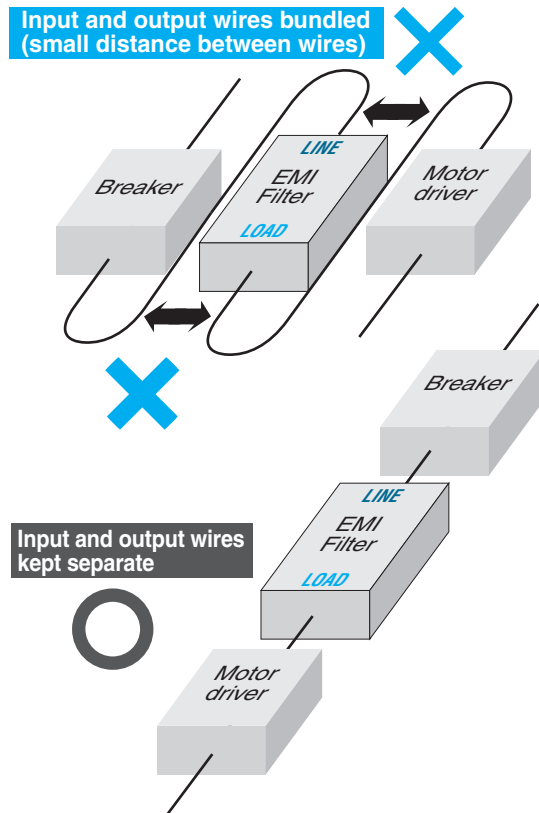

Figure 3.2.2 Input and output wires

4 Noise Reduction

1 Input and Output Impedance and Filter Circuit

The input/output impedances of a noise source and a load will have various optimal filter circuits. General EMI filters take a configuration of a low pass filter that combines L and C. If the expected attenuation effect can not be obtained, impedances of noise source and load may be the reasons.

Table 4.1.1 Combinations of I/O Impedances and Optimal Filters

		Output impedance (Z_o)	
		High	Low
Input impedance (Z_i)	High		
	Low		

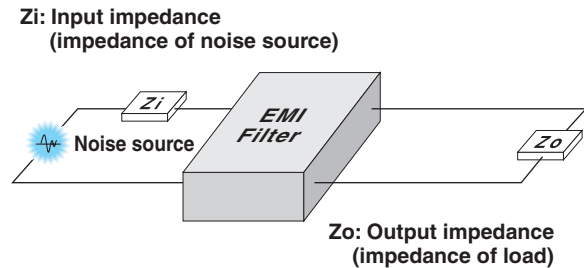

Figure 4.1.1 Input/output Impedances of an EMI Filter Circuit

2 EMI Filter Installation and Orientation

Generally, an EMI filter is placed in a way that the LINE terminal is connected to the input side, but it can also be used in a reverse configuration.

However, it may end up producing a different attenuation effect.

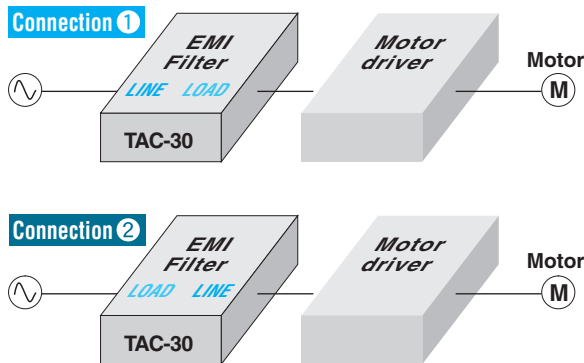

Figure 4.2.1 Direction in which an EMI Filter Is Attached and Connected

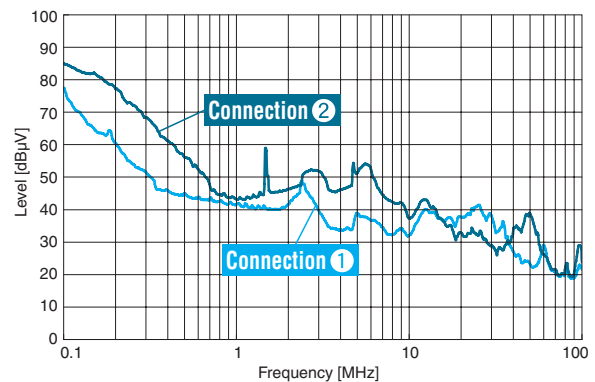

Figure 4.2.2 Example of Effect of Filter Orientation on Noise

If the internal circuit consists of a symmetric EMI filter (one of the NBC series or TBC series), the direction in which the filter is connected will not cause any difference in noise attenuation. But in the case of asymmetric ones, it may cause difference in the attenuation.

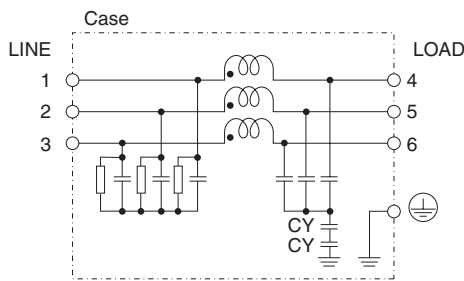

Figure 4.2.3 TAC Series Circuit Diagram (Circuit Is Asymmetric)

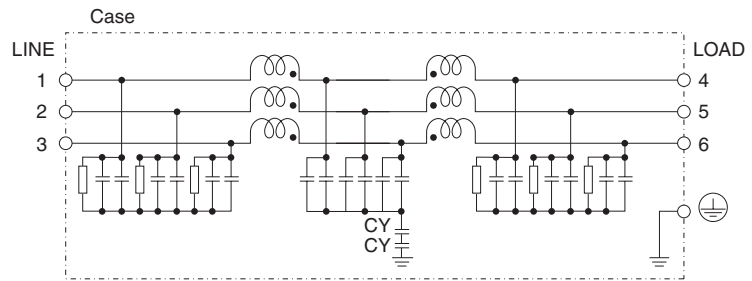

Figure 4.2.4 TBC Series Circuit Diagram (Circuit Is Symmetric)

CY: Line to ground capacitor
 : Mounting Plate

4 Noise Reduction

3 Combining Multiple EMI Filters

If one EMI filter cannot provide sufficient attenuation, the attenuation effect can be improved by connecting two filters in series. However, one must pay attention to the fact that it will result in combining the leakage current and voltage drop of two EMI filters.

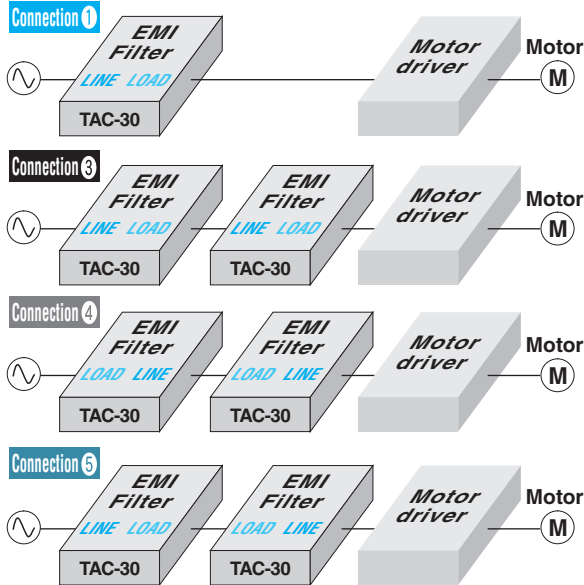

Figure 4.3.1 Example of EMI Filter Connection Directions

When connecting two EMI filters, the direction in which they are connected may also cause difference in the attenuation characteristic. Figure 4.3.3 shows the results of comparing the attenuation characteristics (static characteristics) due to different directions in which two EMI filters are connected.

Figure 4.3.4 shows the actual sample noise characteristics caused by the connection directions.

Unlike the static characteristic data, connection 4 does not improve the attenuation in this case. This phenomenon occurred because the input and output impedances of the EMI filters were different from the conditions of static characteristics.

When trying to optimize the way EMI filters are connected, one must evaluate by checking actual noise levels.

4 External Ferrite Core

If one EMI filter cannot provide sufficient attenuation, the effect can be improved by inserting an external core.

Whether a core is inserted on the LINE side or on the LOAD side of an EMI filter may cause difference in the attenuation characteristic.

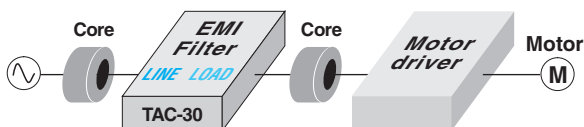

Figure 4.4.1 Example of Placing an External Core

When adding a core on the LINE side, one needs a core that can generate sufficiently large inductance for the choke coil within the EMI filter.

Just inserting on the LINE side a core whose performance is equal to or less than that of the internal choke coil does not contribute to reducing noise.

When inserting it on the LOAD side, it will produce a large attenuation effect because the circuit takes a configuration of a T-type EMI filter circuit.

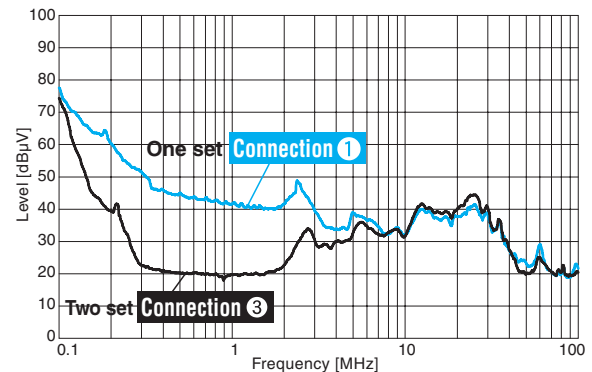

Figure 4.3.2 Example of Effect of Combining Multiple Filters

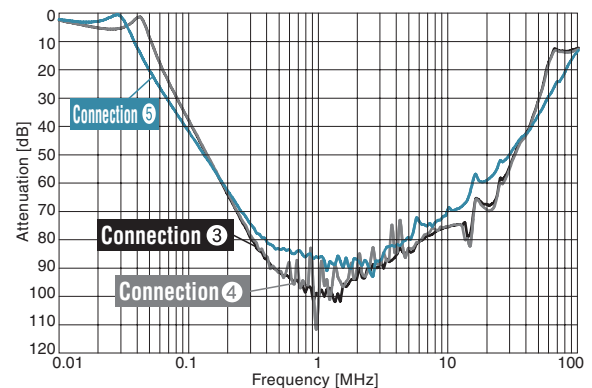

Figure 4.3.3 Comparing Static Characteristics of Different 2-filter configurations

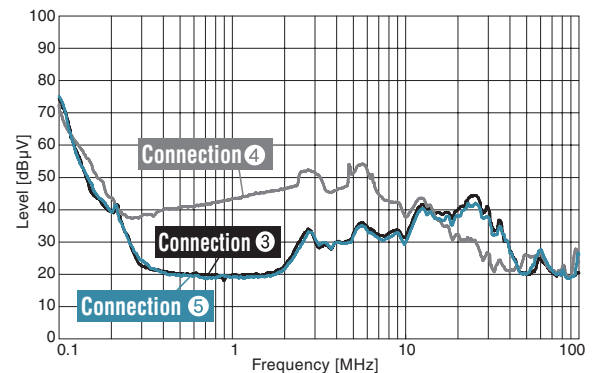

Figure 4.3.4 Comparing Effects of Different 2-filter Configurations

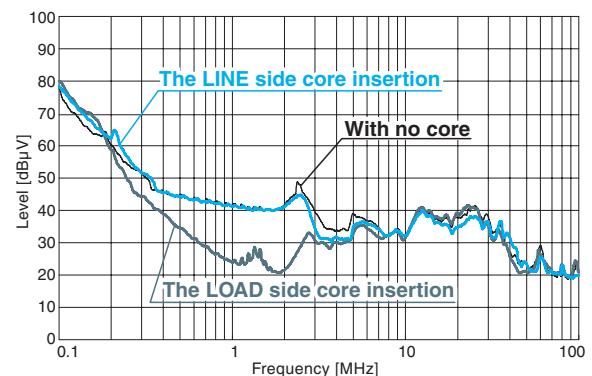

Figure 4.4.2 Example of Effect of Adding an External Ferrite Core

1 CE Marking

For machines and electric products to be sold in the EU area, manufacturers are required to bear a CE mark to prove they are in compliance with safety requirements, quality control, and ecocide prevention. To be allowed to do so, they must meet appropriate EC directives. The following describes the EC directives that are applied to general machinery products:

a. Machinery directive

This directive covers products that are an assembly of parts and have a driving section (with the central focus on industrial equipment).

b. EMC directive

This directive is intended to apply to electric parts which can be sources of radio disturbance or are affected by electromagnetic interference. It requires that two items, emission (EMI) and immunity (EMS), be met.

c. Low voltage directive

This directive is intended to apply to products that operate with a rated voltage in the range of 50 to 1000 V AC or 75 to 1500 V DC.

As there are no appropriate EC directives (including the ones described above) which apply to EMI filters, EMI filter products cannot bear a CE mark.

However, EMI filters can obtain an ENEC mark, which has a similar effect on bypassing application procedures of its signatories.

2 Conducted Emission EN61000-6-4

The voltages of interfering waves propagated through a power cable from equipment to the outside are measured with LISN in an open site or anechoic chamber.

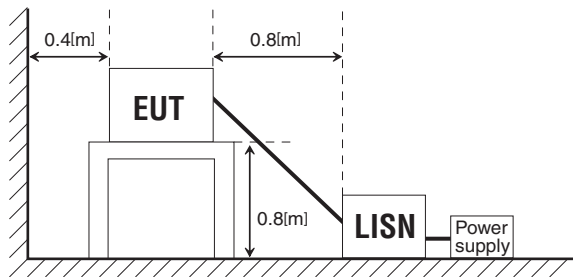

Figure 5.2.1 Example of Conducted Emissions Measurement Configuration

★ : Refer to the description in "Terminology related to EMC Test" in this document.

3 Radiated Emission EN61000-6-4

When operating equipment, the strength of electromagnetic waves is measured in a range of specified frequencies at a location 3 or 10 m away from the equipment

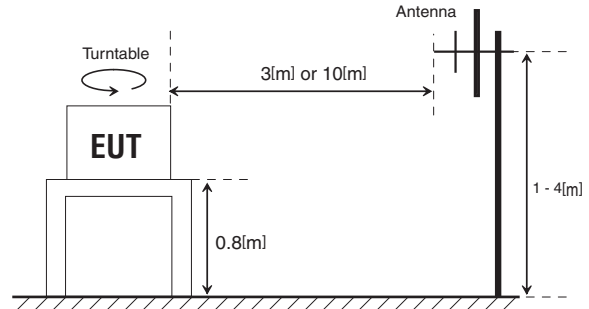

Figure 5.3.1 Example of Radiated Emission Measurement Configuration

4 Power Supply Harmonic Current EN61000-3-2

One analyzes the frequencies of input currents and checks the value of the harmonic current for each order.

5 Electrostatic Discharge EN61000-4-2

This test simulates effects of electrostatic discharge (malfunctions or destruction of semiconductor elements) and includes contact discharge and aerial discharge in its scope.

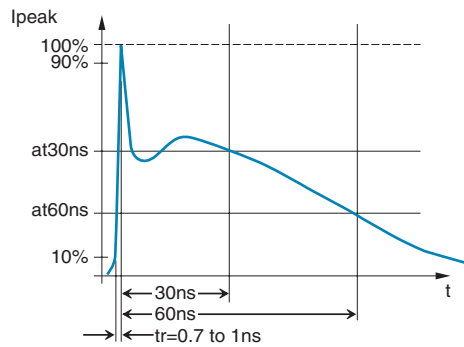

Figure 5.5.1 Discharge current waveform

Table 5.5.1 Application Level

Level	Specified voltage	First peak discharge current ($\pm 10\%$) I_p	Rise time	Current value at 30 ns ($\pm 30\%$)	Current value at 60 ns ($\pm 30\%$)
1	2kV	7.5A	0.7 - 1ns	4A	2A
2	4kV	15A	0.7 - 1ns	8A	4A
3	6kV	22.5A	0.7 - 1ns	12A	6A
4	8kV	30A	0.7 - 1ns	16A	8A

6 Radio frequency electromagnetic field EN61000-4-3

This test checks immunities of equipment to effects of electromagnetic waves.

7 Fast Transient/Burst EN61000-4-4

This test checks immunities to burst waves by from injecting via cable pulses that resemble the results of a discharge.

8 Surge EN61000-4-5

This test checks immunities to surges by applying a specified surge waveform.

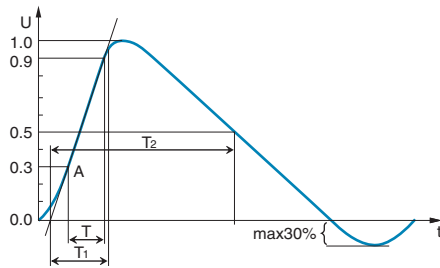

Figure 5.8.1 Example of a Surge Waveform in Voltage

Table 5.8.1 Level

Level	Open circuit test voltage±10% [kV]
1	0.5
2	1.0
3	2.0
4	4.0
X	special

9 Conducted Radio-frequency Interference EN61000-4-6

This test checks immunities to conducted disturbances when electromagnetic waves pass into equipment through a cable.

10 Power Frequency Magnetic Field EN61000-4-8

This test checks immunities to magnetic fields generated by power frequency currents flowing through an input line or a power wiring.

11 Voltage Dip/Momentary Power Interruption EN61000-4-11

These tests check if equipment functions normally after momentary voltage drop, or power failure that decreases voltage to 0.

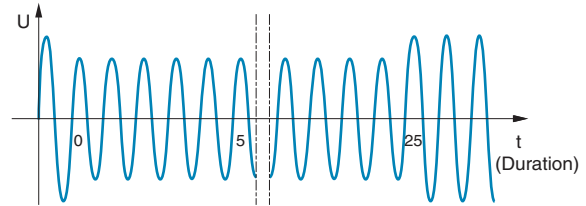

Figure 5.11.1 Example of a Waveform of Voltage Dips

12 Unit of Noise

Noise is represented with 1 [μV] as its reference in [dB]. It is assumed that 1 [μV] equals 0 [dBμV]. For example, 1 [V] is represented as follows:

$$20\text{Log}_{10} \frac{1}{1 \times 10^{-6}} = 120 \text{ [dB}\mu\text{V]}$$

$$\begin{aligned} 10 \text{ [V]} &\Rightarrow 140 \text{ [dB}\mu\text{V]} \\ 100 \text{ [V]} &\Rightarrow 160 \text{ [dB}\mu\text{V]} \\ 1000 \text{ [V]} &\Rightarrow 180 \text{ [dB}\mu\text{V]} \end{aligned}$$

13 Detection Method

a. Peak detection (PK)

It detects the heights of peaks of an output waveform.

b. Quasi-peak detection (QP)

It detects quasi-peaks through a circuit that has time constants at the time of charge and discharge. Quasi-peak detection value equals an intermediate value between peak and average ones.

This detection has high measurement results when noise has a long duration or occurs frequently.

c. Average detection (AV)

It detects an average of values of an output waveform.

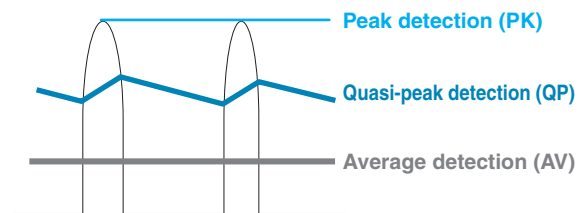

Figure 5.13.1 Relations between Detection Methods and Measurement Levels

14 Conducted and Radiated Emission Limits (Excerpt)

Test item	Standard	EN61000-6-3	EN61000-6-4	EN55011			EN55022		EN60601-1-2			EN50370-1	
	Classification	Common standard	Common standard	Group 1 ★			Standard for product groups		Standard for product groups			Standard for product groups	
	Product	-	-	ISM equipment ★			Information processing equipment (ITE equipment)		ISM equipment (medical equipment)			Machine tool	
		-	-	-	20 kVA or less	Exceeding 20 kVA			-	20 kVA or less	Exceeding 20 kVA	16A or less	Exceeding 16A
	Operating environment	Class B	Class A	Class B	Class A	Class B	Class A	Class B	Class A	Class B	Class A	Class A	Class A

Level:Unit [dBµV]

Conducted emission	Limit	QP	0.1 - 50.5MHz	66 - 56	79	66 - 56	79	100	66 - 56	79	66 - 56	79	100	79	100		
			0.5 - 5MHz	56	73	56	73	86	56	73	56	73	56	73	86	73	86
			5 - 30MHz	60	73	60	73	90 - 73	60	73	60	73	60	73	90 - 73	60	90 - 70
		AV	0.15 - 0.5MHz	56 - 46	66	56 - 46	66	90	56 - 46	66	56 - 46	66	56 - 46	66	90	66	90
			0.5 - 5MHz	46	60	46	60	76	46	60	46	60	46	60	76	60	76
			5 - 30MHz	50	60	50	60	80 - 60	50	60	50	60	50	60	80 - 60	60	80 - 60

Level:Unit [dBµV/m]

Radiated emission	Limit	10m Law	30 - 230MHz	30	40	30	40	50	30	40	30	40	50	40	50		
			230MHz - 1GHz	37	47	37	47	50	37	47	37	47	37	47	50	47	50
		30m Law	30 - 230MHz	-	30	-	-	-	-	-	-	-	-	-	-	-	-
			230MHz - 1GHz	-	37	-	-	-	-	-	-	-	-	-	-	-	-

★ : Refer to the description in "Terminology related to EMC Test" in this document.

(As of November 2011)

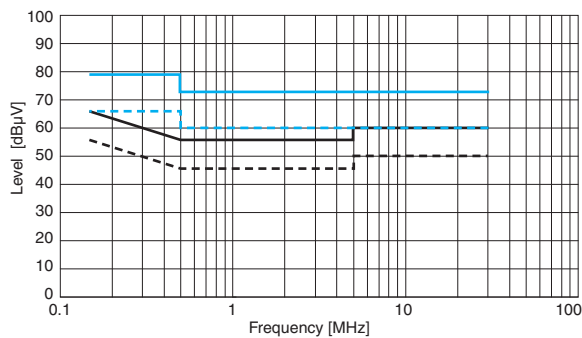

— EN55011 ClassA QP (Group 1)
 - - - EN55011 ClassA AV (Group 1)
 — EN55011 ClassB QP (Group 1)
 - - - EN55011 ClassB AV (Group 1)
 (the above is also applied to EN55013, EN55014-1, EN55022, and EN60601-1)

Figure 5.14.1 Conducted Emission Limit Graph

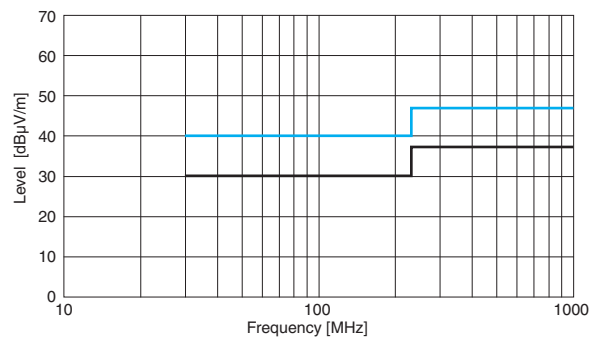

Figure 5.14.2 Radiated Emission Limit Graph

15 Terminology related to EMC Test

★ EUT

Stands for Equipment Under Test, and refers to equipment that will be tested or provided for a test.

★ Immunity test

Refers to a test to evaluate the durability of EUT against electromagnetic interference.

★ Emission test

Refers to a test to evaluate whether the strength of electromagnetic interference emitted from EUT exceeds a given limit.

★ Open site

Refers to an experimental facility installed outdoors to be used for activities such as EMC measurement.

★ Anechoic chamber

Refers to a facility to be used to create an electromagnetically isolated environment; the interior surfaces of the chamber absorb radio frequency waves.

★ CISPR

One of IEC's special committees; it was established to integrate standards such as those for allowable values and measurement methods for interfering waves causing radio communication failures and includes a standardization committee for EMC (Electro Magnetic Compatibility).

★ Group 1 and Group 2 in EN55011

Group1 : Equipment for laboratories, healthcare, and sciences (Example: frequency counters, spectrum analyzers, switching power source, and measuring apparatus)

Group2 : Industrial induction heating equipment, induction heating equipment, industrial microwave heating equipment, household microwave ovens, medical equipment, spark erosion equipment, and spot welders.

























★ ISM equipment

Stands for Industrial, Scientific and Medical radio-frequency equipment and refers to radio-frequency equipment for industry, science, and health care.

★ LISN

Stands for Line Impedance Stabilization Network. It refers to equipment that sends noise components to a measurement device while monitoring impedances, looking at the power source from EUT. It is also called AMN (Artificial Mains Network).

1 Source Voltages in the World

	People's Republic of China	Single phase 2 wire 220V	Three phase 4 wire 380V
	Taiwan	Single phase 2 wire 110V, 220V	Three phase 4 wire 380V
	India	Single phase 2 wire 230V, 240V	Three phase 4 wire 400V, 415V
	Indonesia	Single phase 2 wire 220V	Three phase 4 wire 380V
	Japan	Single phase 2 wire 100V, 200V	Three phase 3 wire 200V
	Korea	Single phase 2 wire 110V, 220V	Three phase 3 wire 200V Three phase 4 wire 380V
	Philippines	Single phase 2 wire 220V, 230V, 240V	Three phase 3 wire 480V
	Singapore	Single phase 2 wire 230V	Three phase 4 wire 400V
	Thailand	Single phase 2 wire 220V	Three phase 4 wire 380V
	Malaysia	Single phase 2 wire 240V	Three phase 4 wire 415V
	Egypt	Single phase 2 wire 220V	Three phase 4 wire 380V
	Saudi Arabia	Single phase 2 wire 127V, 220V	Three phase 4 wire 380V
	Australia	Single phase 2 wire 240V	Three phase 4 wire 415V
	New Zealand	Single phase 2 wire 230V, 240V	Three phase 4 wire 400V, 415V
	Austria	Single phase 2 wire 230V	Three phase 4 wire 400V
	France	Single phase 2 wire 230V	Three phase 4 wire 400V
	Germany	Single phase 2 wire 230V	Three phase 4 wire 400V
	UK	Single phase 2 wire 240V	Three phase 4 wire 415V
	Netherlands	Single phase 2 wire 230V	Three phase 4 wire 400V
	Italy	Single phase 2 wire 220V	Three phase 4 wire 380V
	Spain	Single phase 2 wire 127V, 220V	Three phase 4 wire 380V
	Switzerland	Single phase 2 wire 230V	Three phase 4 wire 400V
	Russia (former republics of the Soviet Union)	Single phase 2 wire 127V, 220V	Three phase 4 wire 380V
	USA	Single phase 2 wire 120V, 265V, 277V Single phase 3 wire 115/230V, 120/240V, 240/480V	Three phase 4 wire 208V, 460V, 480V
	Brazil	Single phase 2 wire 127V	Three phase 4 wire 220V

EAC/EAM/EAP series

EAC -10 -472 -□

① ② ③ ④

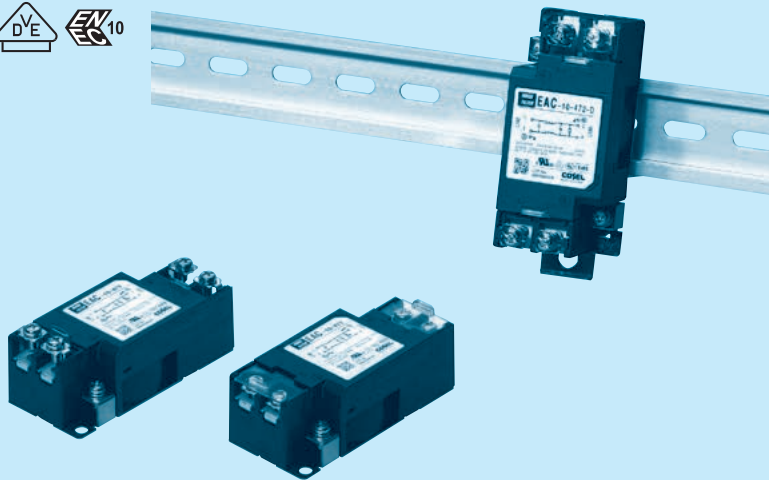

The terminal cover is retracted inside the unit

DIN rail installation type is option

- ① Series Name
- ② Rated Current
- ③ Line to ground capacitor code: Refer to table 1.1.

table 1.1 Line to ground capacitor code

Code	E A C	E A M	E A P	Leakage Current (Input 125/250V 60Hz)	Line to ground capacitor (nominal value)
000	●	●	●	5 μ A / 10 μ A max	Not Provided
101	●	●	●	12.5 μ A / 25 μ A max	100pF
221	●	●	●	25 μ A / 50 μ A max	220pF
331	●	●	●	37.5 μ A / 75 μ A max	330pF
471	●	●	●	50 μ A / 100 μ A max	470pF
681	●	●	●	75.5 μ A / 150 μ A max	680pF
102	●	●	●	0.13mA / 0.25mA max	1,000pF
222	●	●	●	0.25mA / 0.5 mA max	2,200pF
332	●	●	●	0.38mA / 0.75mA max	3,300pF
472	●	●	●	0.5 mA / 1.0 mA max	4,700pF

*When the line to ground capacitor code is different, the attenuation characteristic is different.

- ④ Option
- D: DIN rail installation type

* The dimensions change when the option is set. Refer to External view.

Features of EAC/EAM/EAP series

- Single Phase 250VAC (1-Stage filter)
 - Small size
 - Quick and easy push-down terminal
- Just connect the wires, push-down and tighten the screws with a screwdriver

■ EAC: Attenuation type from 150kHz to 1MHz

■ EAM: Low leakage current type

■ EAP: Outside impulse attenuation type

Specifications

No.	Items	EAC-03-472	EAC-06-472	EAC-10-472	EAC-16-472	EAC-20-472	EAC-30-472
		EAM-03-000	EAM-06-000	EAM-10-000	EAM-16-000	EAM-20-000	EAM-30-000
		EAP-03-472	EAP-06-472	EAP-10-472	EAP-16-472	EAP-20-472	EAP-30-472
1	Rated Voltage[V]	AC 1 ϕ 250 / DC250					
2	Rated Current[A]	3	6	10	16	20	30
3	Test Voltage (Terminal-Mounting Plate)	2,500 VAC (Cutoff Current = 20mA), 1minute at room temperature and humidity					
4	Isolation Resistance (Terminal-Mounting Plate)	500 VDC 500M Ω min at room temperature and humidity					
5	Leakage current	Refer to table 1.1					
6	DC resistance	180m Ω max	110m Ω max	40m Ω max	20m Ω max	10m Ω max	6m Ω max
7	Safety agency approval temperatures	-25 to +85 $^{\circ}$ C (Refer to Derating Curve)					
8	Operating temperature	-40 to +85 $^{\circ}$ C (Refer to Derating Curve)					
9	Operating humidity	20 to 95%RH (Non condensing)					
10	Storage temperature/humidity	-40 to +85 $^{\circ}$ C/20 to 95%RH (Non condensing)					
11	Vibration	10 to 55Hz, 19.6m/s 2 (2G), 3min. Period, 1hour each X, Y and Z axis					
12	Impact	196.1m/s 2 (20G), 11ms Once each X, Y and Z axis					
13	Safety agency approvals	UL1283, CSA C22.2 No.8 (C-UL), DIN EN60939 VDE0565 Teil3-1, ENEC (At only AC input)					
14	Case size (without projection) /Weight	39 X 30 X 85 mm [1.54 X 1.18 X 3.35 inches] (W X H X D) /170g max (Option : -D refer to external view)					

Circuit Diagram

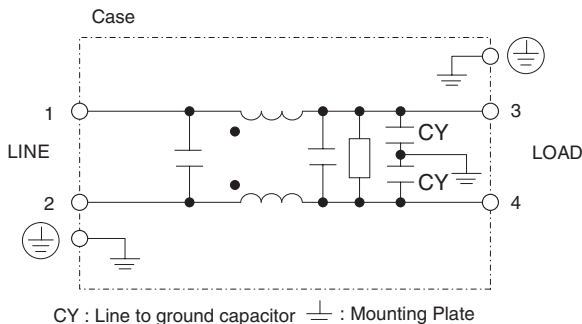

Derating Curve

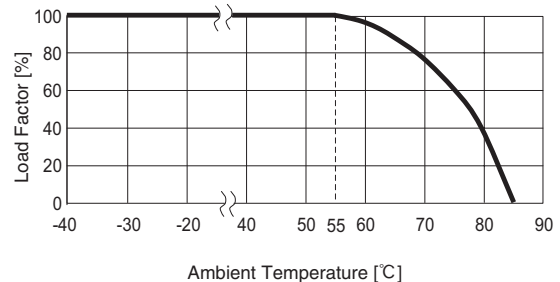

External view

This product is shipped in the following condition, because it is equipped with push-down terminals.

- ① The terminal cover is retracted inside the unit.
- ② The screws for connecting the terminals are held in the up right position.

Standard Type

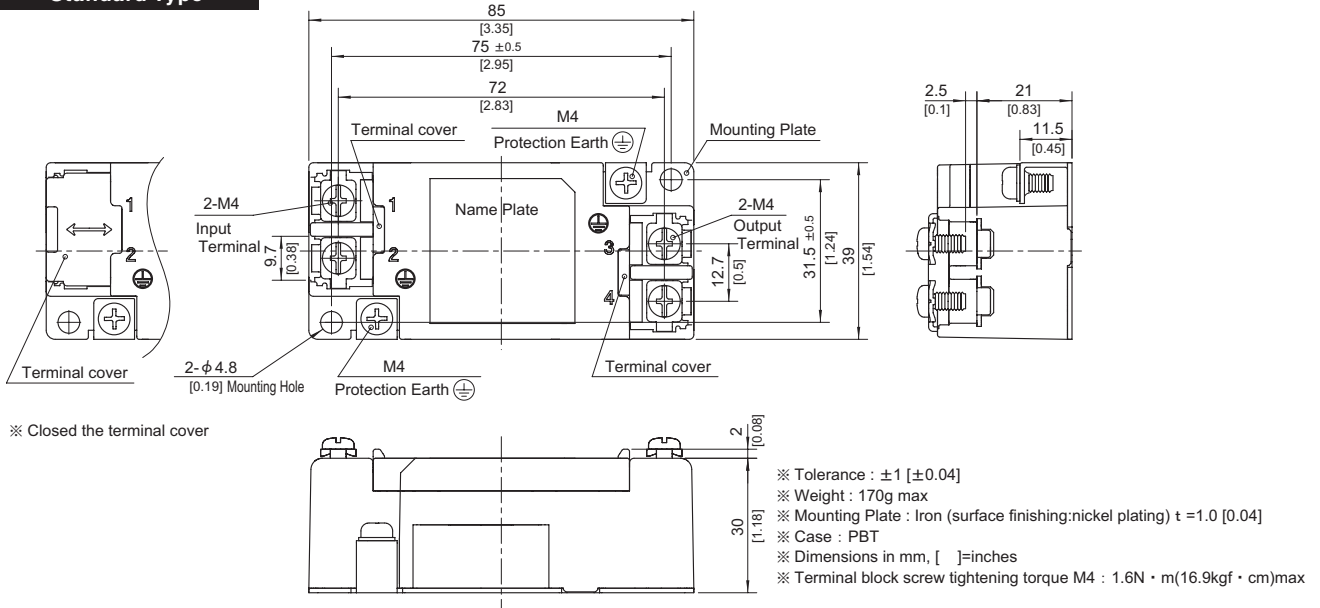

DIN rail installation Type

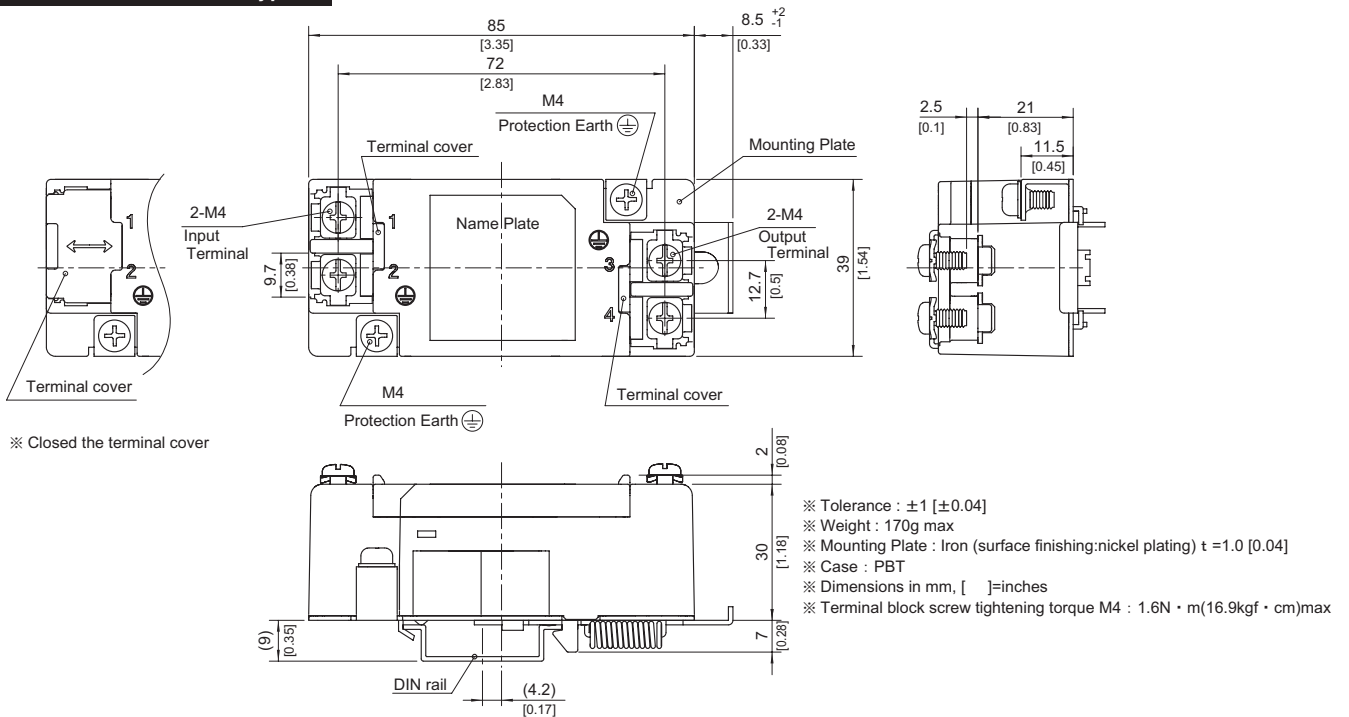

■ Note when installing the EMI/EMC Filter on a DIN rail.

When the EMI/EMC Filter is grounded through the DIN rail, the proper noise attenuation may not be achieved.

Be sure to connect the protection earth (PE) of the EMI/EMC Filter body to the earth. At least one PE connection is required.

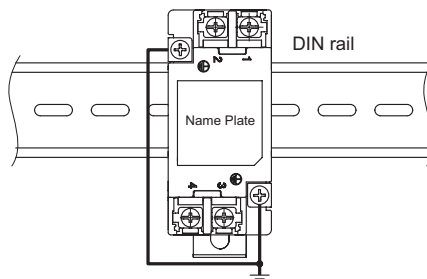

ESC/ESM/ESP series

ESC -10 -472 -□

① ② ③ ④

- ① Series Name
- ② Rated Current
- ③ Line to ground capacitor code: Refer to table 1.1.

table 1.1 Line to ground capacitor code

Code	E S C	E S M	E S P	Leakage Current (Input 125/250V 60Hz)	Line to ground capacitor (nominal value)
000	●	●	●	5 μ A / 10 μ A max	Not Provided
101	●	●	●	12.5 μ A / 25 μ A max	100pF
221	●	●	●	25 μ A / 50 μ A max	220pF
331	●	●	●	37.5 μ A / 75 μ A max	330pF
471	●	●	●	50 μ A / 100 μ A max	470pF
681	●	●	●	75.5 μ A / 150 μ A max	680pF
102	●	●	●	0.13 mA / 0.25mA max	1,000pF
222	●	●	●	0.25 mA / 0.5 mA max	2,200pF
332	●	●	●	0.38 mA / 0.75mA max	3,300pF
472	●	●	●	0.5 mA / 1.0 mA max	4,700pF

* When the line to ground capacitor code is different, the attenuation characteristic is different.

- ④ Option
- D: DIN rail installation type

* The dimensions change when the option is set. Refer to External view.

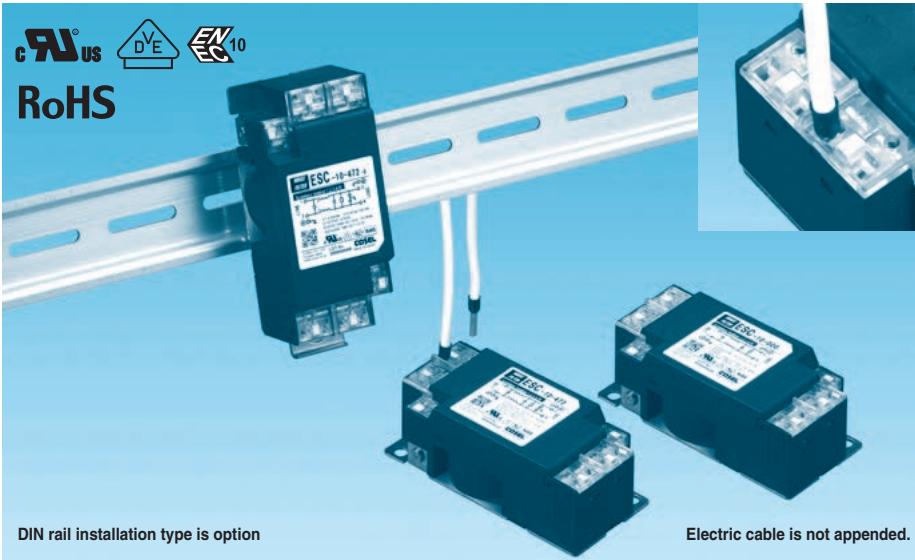

Features of ESC/ESM/ESP series

- Single Phase 250VAC (1-Stage filter)
- Small EMI/EMC Filters that change input-output terminal and protection earth terminal of EA series into screwless terminal type
- Torque management is unnecessary with screwless

■ ESC : Attenuation type from 150kHz to 1MHz

■ ESM : Low leakage current type

■ ESP : Outside impulse attenuation type

Specifications

No.	Items	ESC-03-472	ESC-06-472	ESC-10-472	ESC-16-472
		ESM-03-000	ESM-06-000	ESM-10-000	ESM-16-000
		ESP-03-472	ESP-06-472	ESP-10-472	ESP-16-472
1	Rated Voltage[V]	AC 1 ϕ 250 / DC250			
2	Rated Current[A]	3	6	10	16
3	Test Voltage (Terminal-Mounting Plate)	2,500 VAC (Cutoff Current = 20mA), 1minute at room temperature and humidity			
4	Isolation Resistance (Terminal-Mounting Plate)	500 VDC 500M Ω min at room temperature and humidity			
5	Leakage current	Refer to table 1.1			
6	DC resistance	180m Ω max	110m Ω max	40m Ω max	20m Ω max
7	Safety agency approval temperatures	-25 to +85 $^{\circ}$ C (Refer to Derating Curve)			
8	Operating temperature	-40 to +85 $^{\circ}$ C (Refer to Derating Curve)			
9	Operating humidity	20 to 95%RH (Non condensing)			
10	Storage temperature/humidity	-40 to +85 $^{\circ}$ C/20 to 95%RH (Non condensing)			
11	Vibration	10 to 55Hz, 19.6m/s 2 (2G), 3min. Period, 1hour each X, Y and Z axis			
12	Impact	196.1m/s 2 (20G), 11ms Once each X, Y and Z axis			
13	Safety agency approvals	UL1283, CSA C22.2 No.8 (C-UL), DIN EN60939 VDE0565 Teil3-1, ENEC (At only AC input)			
14	Case size (without projection) /Weight	39X30X85 mm [1.54X1.18X3.35 inches] (W X H X D) /170g max (Option : -D refer to external view)			

Circuit Diagram

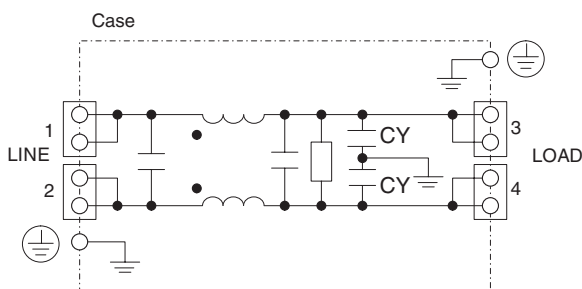

CY : Line to ground capacitor \perp : Mounting Plate

Derating Curve

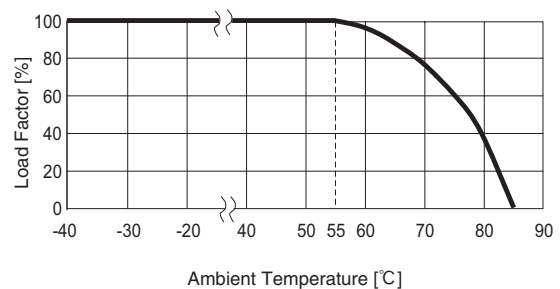

External view

Standard Type

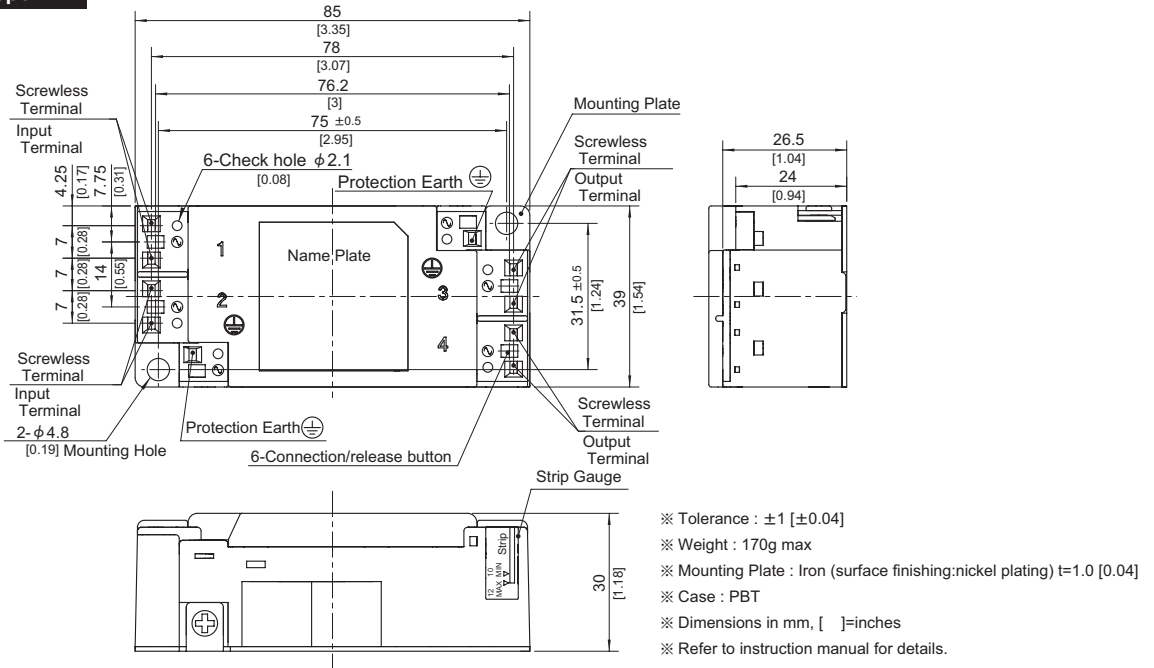

DIN rail installation Type

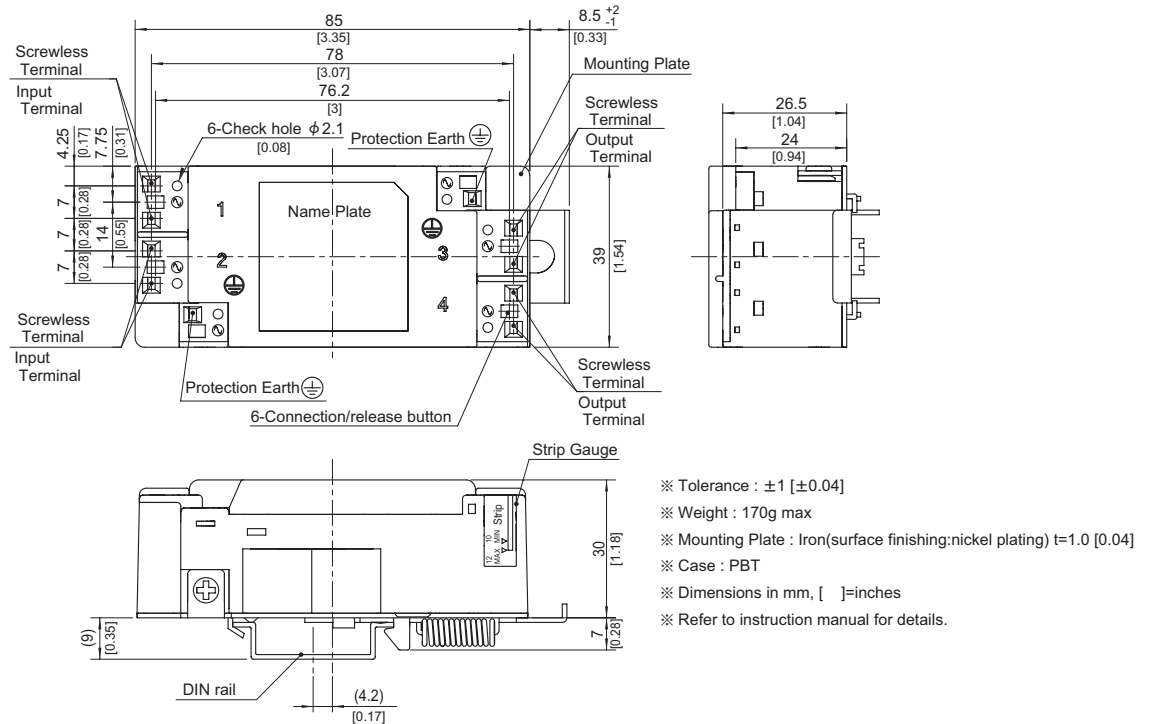

■Note when installing the EMI/EMC Filter on a DIN rail.

When the EMI/EMC Filter is grounded through the DIN rail, the proper noise attenuation may not be achieved.

Be sure to connect the protection earth (PE) of the EMI/EMC Filter body to the earth. At least one PE connection is required.

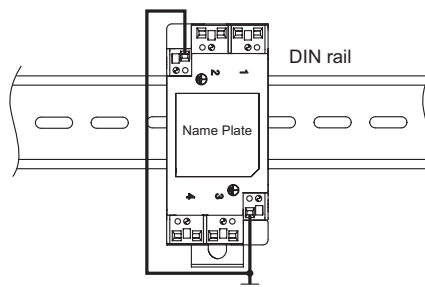

EAC-03-472 / ESC-03-472

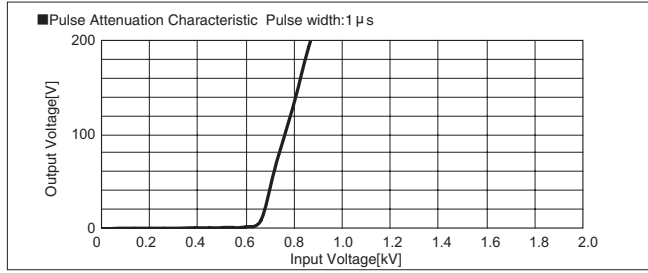
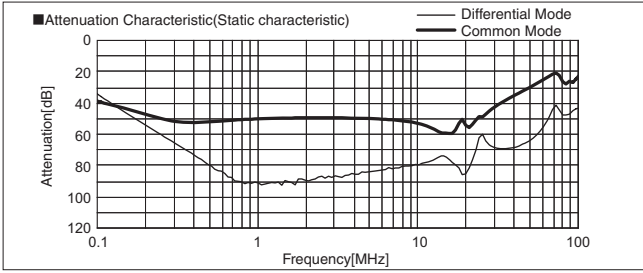

EAC-06-472 / ESC-06-472

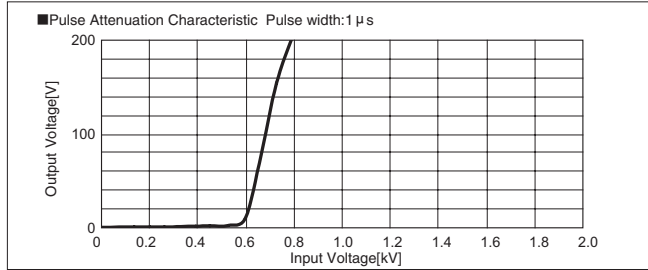
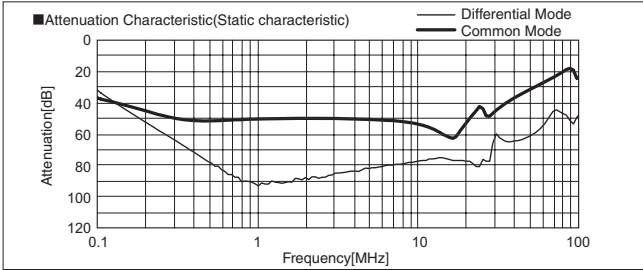

EAC-10-472 / ESC-10-472

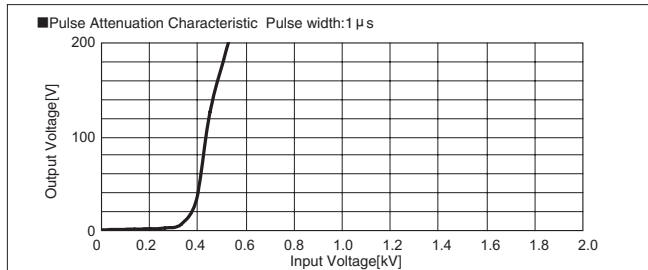
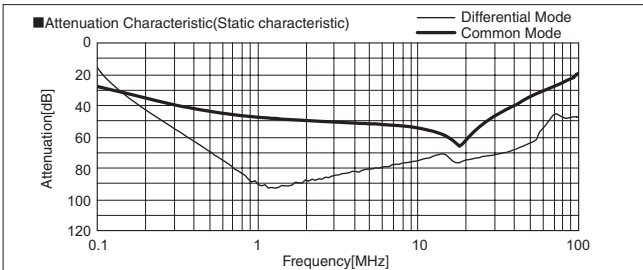

EAC-16-472 / ESC-16-472

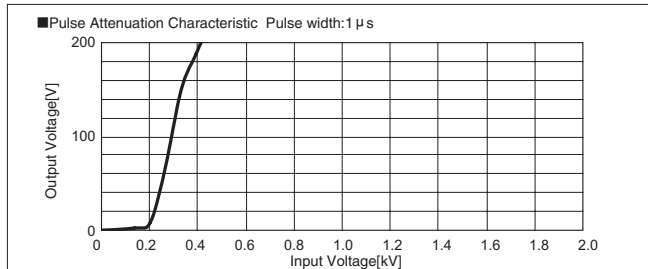
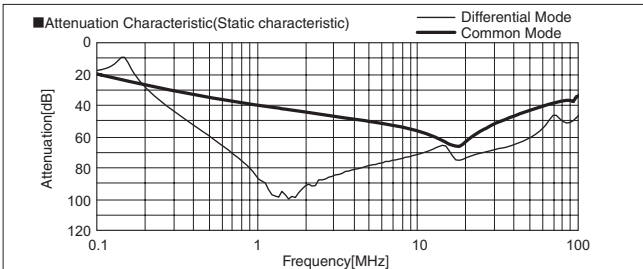

EAC-20-472

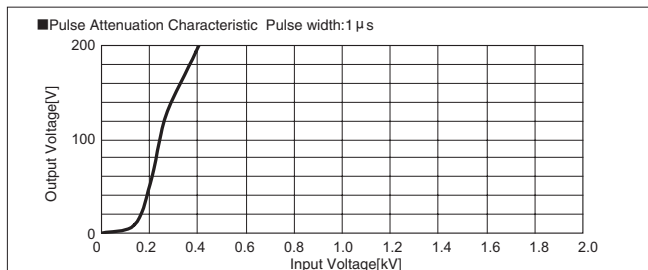
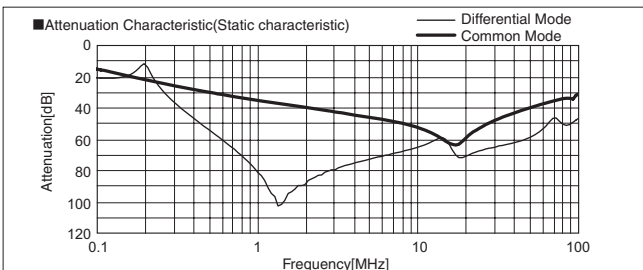

EAC-30-472

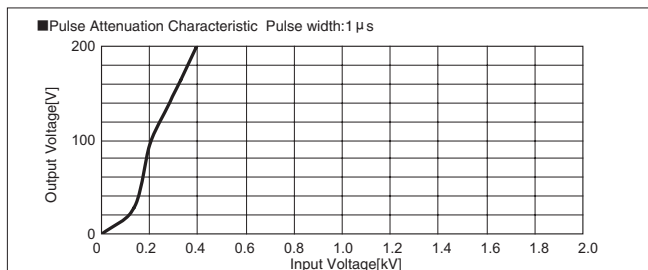
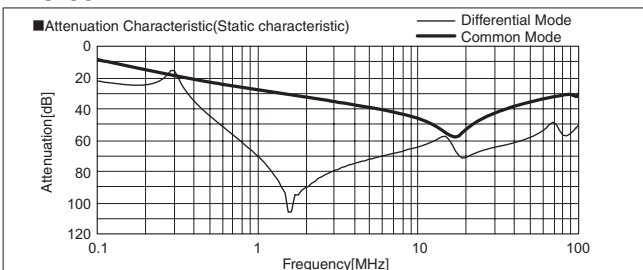

EAM-03-000 / ESM-03-000

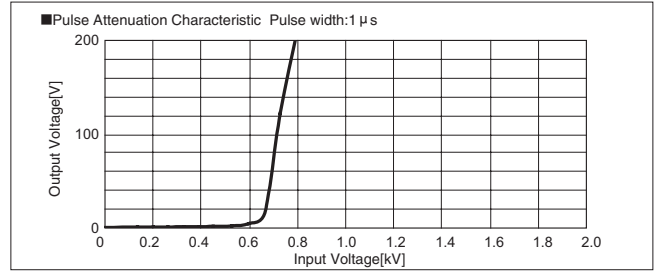
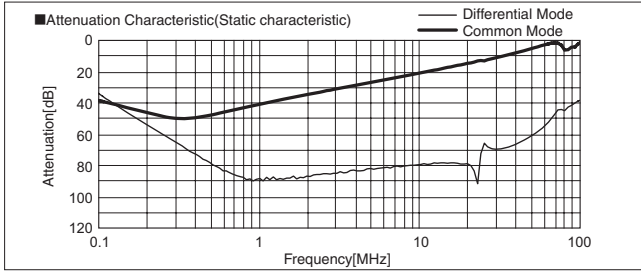

EAM-06-000 / ESM-06-000

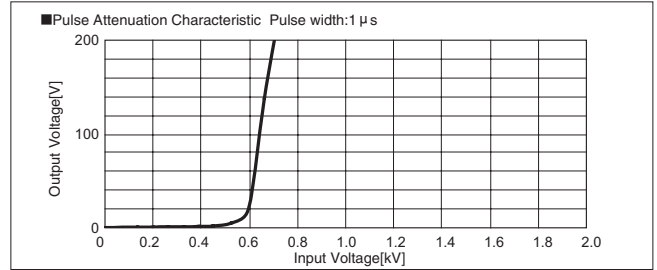
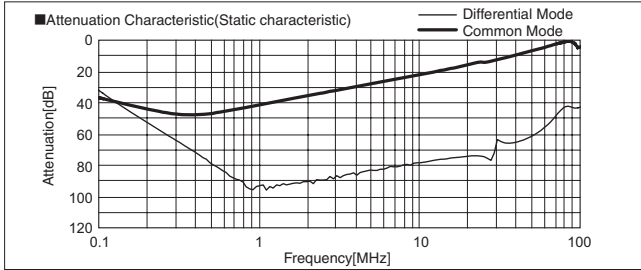

EAM-10-000 / ESM-10-000

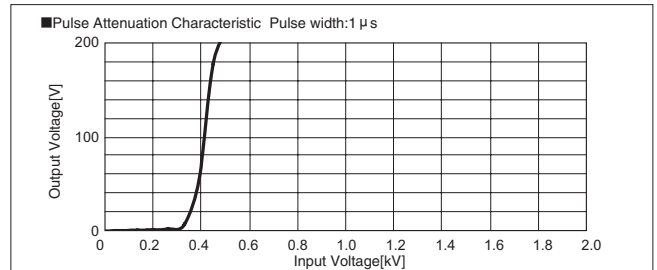
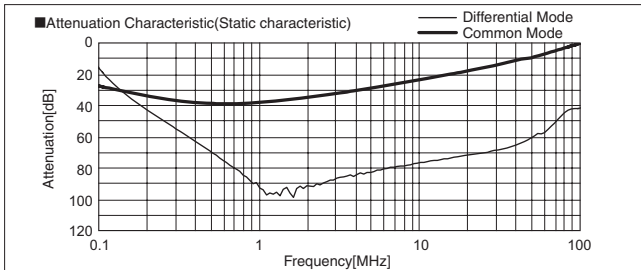

EAM-16-000 / ESM-16-000

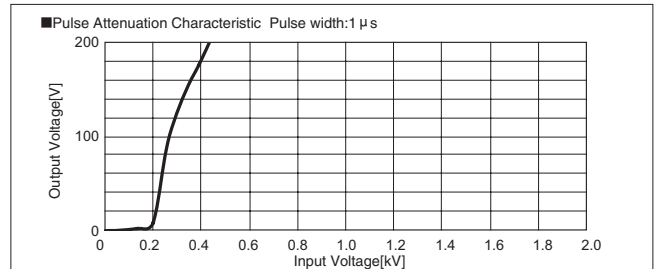
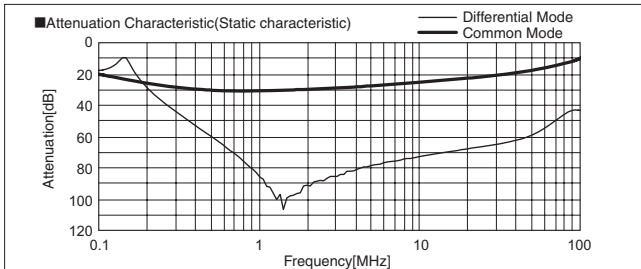

EAM-20-000

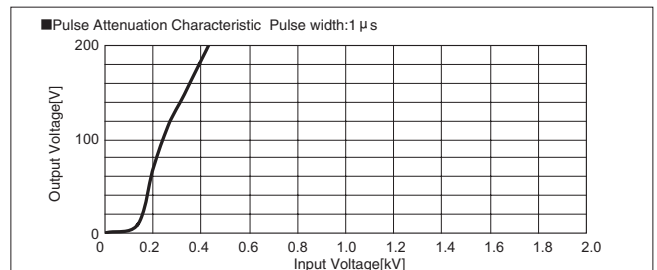
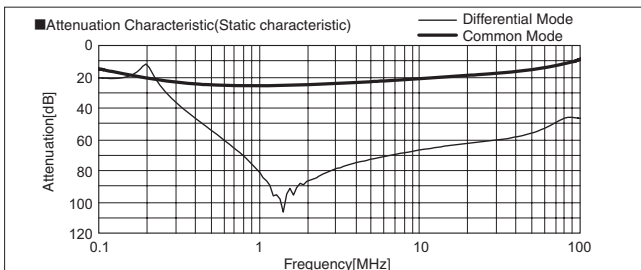

EAM-30-000

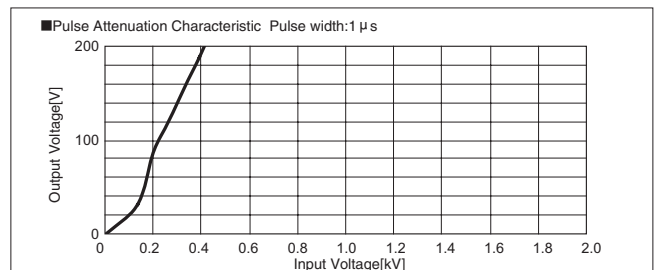
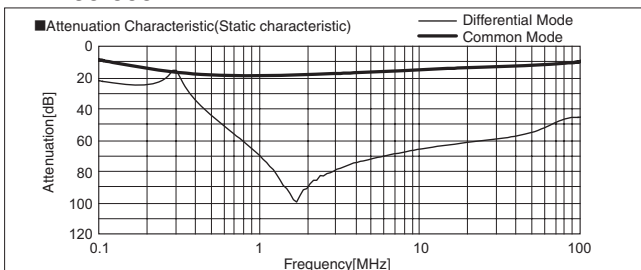

EAP-03-472 / ESP-03-472

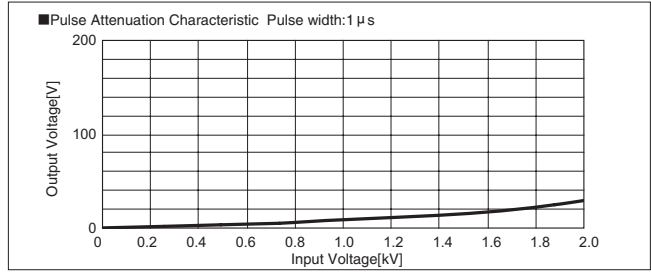
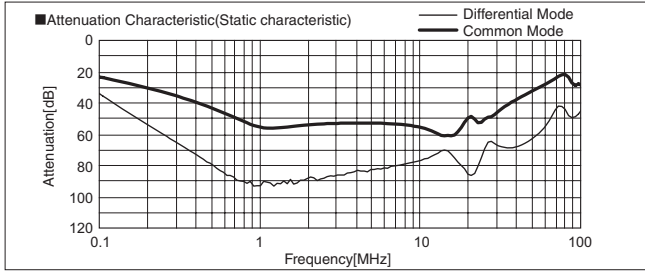

EAP-06-472 / ESP-06-472

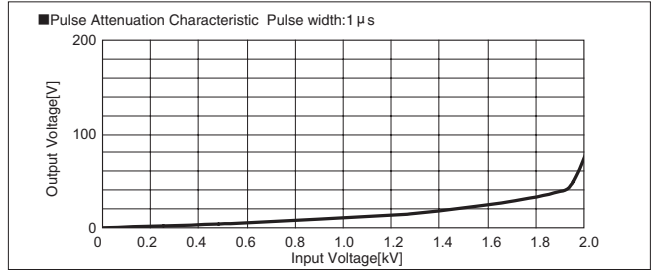
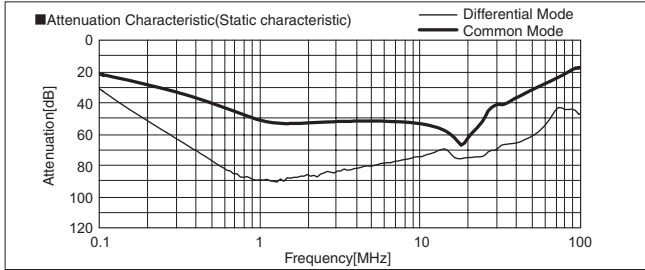

EAP-10-472 / ESP-10-472

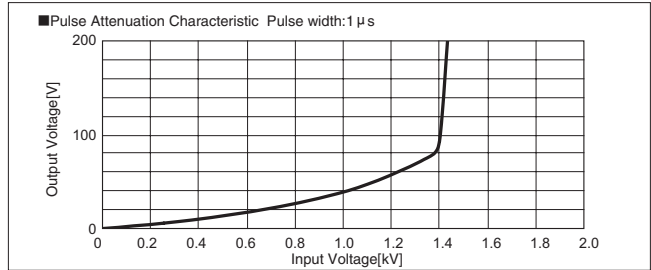
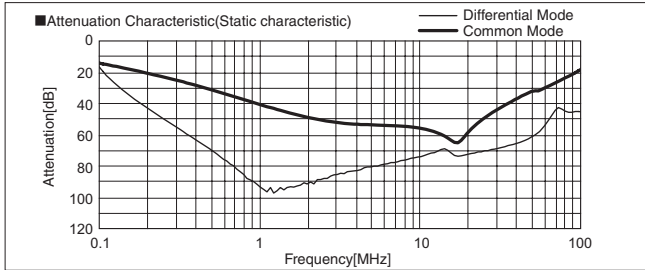

EAP-16-472 / ESP-16-472

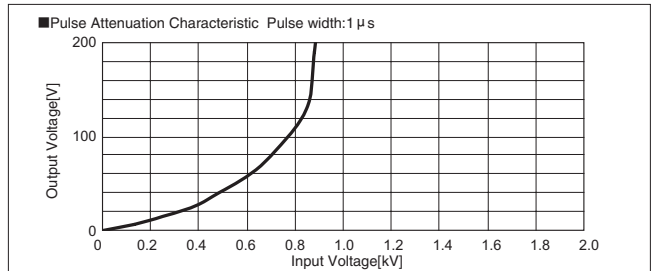
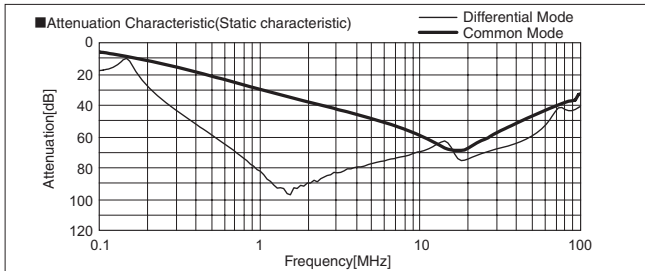

EAP-20-472

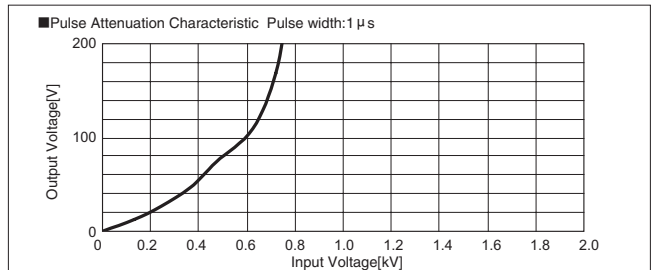
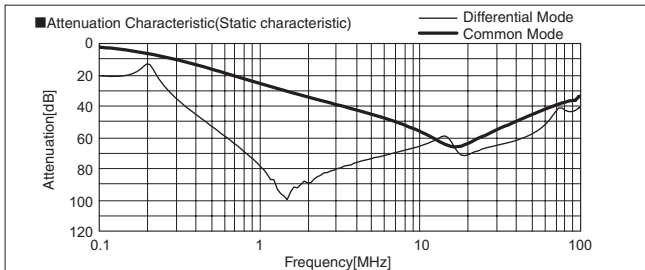

EAP-30-472

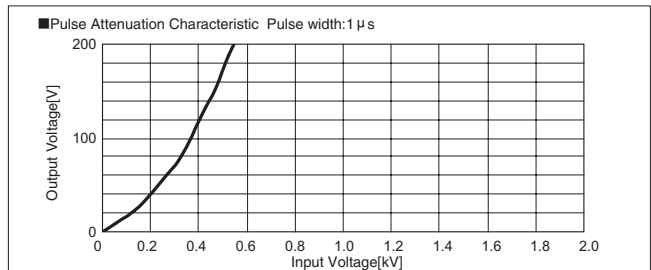
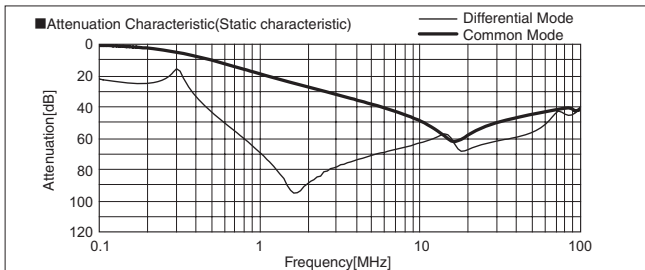

1 Applicable Electric Cable

- Only use the electric cable that exists in the Table1.
- Use the cable that conductor material is copper. Do not use the cable that conductor material is iron or aluminum. Never use the one other than the electric cable.
Ex. Steel wire, Stick made of resin, other wire
- Note that the current rating is different in each electric cable.
- Strip so as not to damage the conductor at stripping sheath.
- Strip specified length of cable sheath (Refer to Table1).
Strip Length can be confirmed with a gauge of the body case. Refer to External view.
- Do not put solder on the conductor. It becomes impossible to connect cable.

Table.1 Applicable Wire

Solid wire	Diameter 0.5mm to 1.2mm (AWG.22 to AWG.16)
Stranded wire	0.3mm ² to 1.25mm ² (AWG.22 to AWG.16) Conductor diameter more than 0.18 mm
Sheath strip length	10mm to 12mm

2 Applicable bar-type terminal

- The applicable bar-type terminal (Refer to Table 2) must be used, and after crimp, the size of bar-type terminal must be kept value of Table 3. Use the applicable terminal (Refer to Table 2) and keep the size of terminal, or you will not be able to connect cable. Contact us when the bar-type terminals other than the applicable bar-type terminal (Refer to Table 2) are used.
- Connect cable so as not to conceal the button with the sleeve of the cable when a round terminals other than the applicable terminal are used.

Table.2 Applicable bar-type terminal

Manufacturer	Size	model	Crimp tool
Phoenix Contact	AWG.22	AI0.34-12TQ	CRIMPFOX UD6-4
	AWG.20	AI0.5-10WH AI0.5-12WH	
	AWG.18	AI0.75-10GY AI0.75-12GY AI1-10RD AI1-12RD	
	AWG.16	AI1.5-10BK AI1.5-12BK	
Nichifu	AWG.22-16	TGN TC-1.25-11T TGV TC-1.25-11T	NH11 NH32 NH65

<Square type>

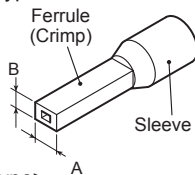

<Round type>

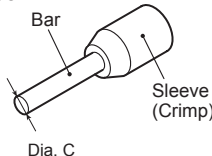
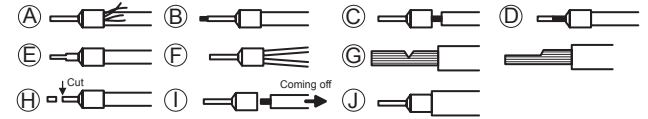

Table.3 Dimension of terminal at crimp
[Dimensions in mm]

Part	Dimension
A	1.1 to 2.6
B	0.8 to 1.6
Dia. C	0.8 to 1.6

3 State of crimped bar-type terminal

● Bad condition



- Ⓐ The wire protrudes from the sleeve.
- Ⓑ The conductor extremely protrudes from the point of the bar-type terminal.
- Ⓒ The electric conductor is not inserted enough and the conductor has been exposed from the terminal.
- Ⓓ The sheath strip length doesn't suffice and the conductor is not enough inserted in the ferrules.
- Ⓔ Crimp is only the point of conductor.
- Ⓕ It crimps two electric cables.
- Ⓖ There is a damage or a disconnection part in the conductor.
- Ⓗ The point of the terminal is cut.
- Ⓘ It comes off the terminal when the cable is pulled.
- Ⓙ The sheath of the cable protrudes from the sleeve.

4 Wiring Terminal Blocks (connecting/releasing)

- One electric cable one insertion hole. When two or more is connected, it causes trouble.
- Do connecting and releasing of the electric cable by using a flat-blade driver while pushing the connection/release button. Moreover, insert the conductor or the bar-type terminal to the end fully.
- When you connect the stranded cable, connect wires after lightly stranding wires.
- Confirm the electric cable is surely connected with the terminal after connecting.
- The check hole can be used for the check of wire connecting and insulation and for the operation monitor etc.

● Connecting : Stranded cable, Solid cable (Diameter 0.5 to 0.9)

- StepI Push the button with a flat-blade driver.
- StepII Insert the cable into the hole while pushing the button.
- StepIII Release the flat-blade driver and cable connection is completion.

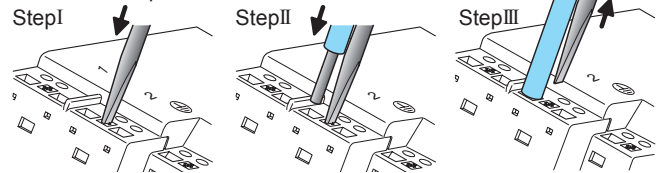

● Connecting : Solid wire (except diameter 0.5 to 0.9), bar type terminal

Insert the cable into the insertion hole.

* Insert it while pushing the button when it is not easy to insert it.

● Releasing : Stranded wire, Solid wire, bar type terminal

Pull out the electric cable while pushing the button with flat-blade driver.

* Notice : Two insertion holes are released at the same time by pushing the button once. (Except PE terminal)

- Use the flat-blade driver that meets the size in Table 4.

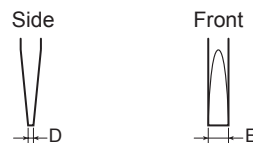

Table.4 Dimension of flat-blade driver
[Dimensions in mm]

Part	Dimension
D	1.0max
E	3.0max

NAC/NAM/NAH/NAP series(4-30A)

NAC -10 -472 -□

① ② ③ ④

- ① Series Name
- ② Rated Current
- ③ Line to ground capacitor code: Refer to table 1.1.

table 1.1 Line to ground capacitor code

Code	N A C	N A H	N A P	Leakage Current (Input 125/250V 60Hz)	Line to ground capacitor (nominal value)
000	●	●	●	5 μ A / 10 μ A max	Not Provided
101	●	●	●	12.5 μ A / 25 μ A max	100pF
221	●	●	●	25 μ A / 50 μ A max	220pF
331	●	●	●	37.5 μ A / 75 μ A max	330pF
471	●	●	●	50 μ A / 100 μ A max	470pF
681	●	●	●	75.5 μ A / 150 μ A max	680pF
102	●	●	●	0.13 mA / 0.25mA max	1,000pF
222	●	●	●	0.25 mA / 0.5 mA max	2,200pF
332	●	●	●	0.38 mA / 0.75mA max	3,300pF
472	●	●	●	0.5 mA / 1.0 mA max	4,700pF

* When the line to ground capacitor code is different, the attenuation characteristic is different.

- ④ Option
- D: DIN rail installation type

* The dimensions change when the option is set. Refer to External view.

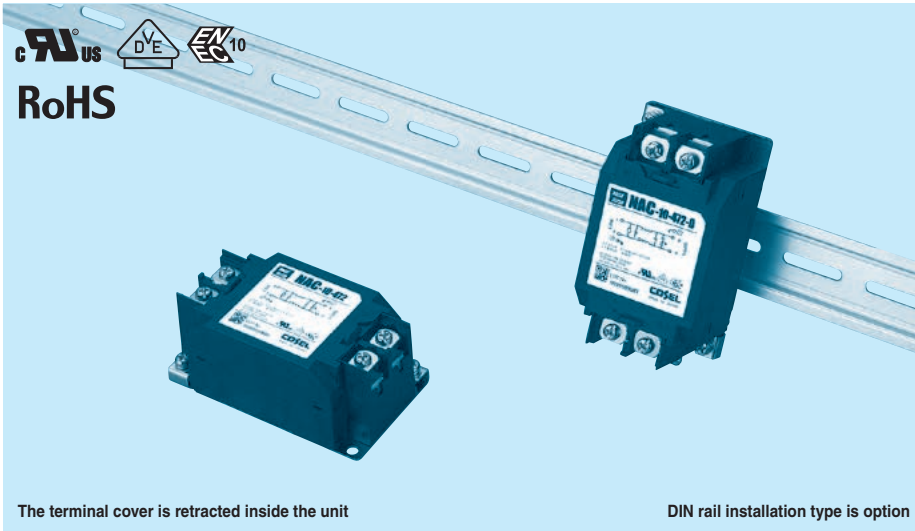

The terminal cover is retracted inside the unit

DIN rail installation type is option

Features of NAC/NAM/NAH/NAP series

- Single Phase 250VAC (1-Stage filter)
 - Quick and easy push-down terminal
- Just connect the wires, push-down and tighten the screws with a screwdriver

- NAC : High-attenuation type from 150kHz to 1MHz
- NAM: Low leakage current type
- NAH: Ultra high-attenuation type from 9kHz to 1MHz
- NAP : Outside impulse high-attenuation type

Specifications

No.	Items	NAC-04-472	NAC-06-472	NAC-10-472	NAC-16-472	NAC-20-472	NAC-30-472
		NAM-04-000	NAM-06-000	NAM-10-000	NAM-16-000	NAM-20-000	NAM-30-000
		-	NAH-06-472	NAH-10-472	NAH-16-472	NAH-20-472	NAH-30-472
		NAP-04-472	NAP-06-472	NAP-10-472	NAP-16-472	NAP-20-472	NAP-30-472
1	Rated Voltage[V]	AC 1 ϕ 250 / DC250					
2	Rated Current[A]	4	6	10	16	20	30
3	Test Voltage (Terminal-Mounting Plate)	2,500 VAC (Cutoff Current = 20mA), 1minute at room temperature and humidity					
4	Isolation Resistance (Terminal-Mounting Plate)	500 VDC 100M Ω min at room temperature and humidity					
5	Leakage current	Refer to table 1.1					
6	Voltage drop	1.0V max					
7	Safety agency approval temperatures	-25 to +85°C (Refer to Derating Curve)					
8	Operating temperature	-40 to +85°C (Refer to Derating Curve)					
9	Operating humidity	20 to 95%RH (Non condensing)					
10	Storage temperature/humidity	-40 to +85°C/20 to 95%RH (Non condensing)					
11	Vibration	10 to 55Hz, 19.6m/s ² (2G), 3min. Period, 1hour each X, Y and Z axis					
12	Impact	196.1m/s ² (20G), 11ms Once each X, Y and Z axis					
13	Safety agency approvals	UL1283, CSA C22.2 No.8 (C-UL), DIN EN60939 VDE0565 Teil3-1, ENEC (At only AC input)					
14	Case size (without projection) /Weight	53X41X92 mm [2.09X1.61X3.62 inches] (W X H X D) /300g max (Option : -D refer to external view)					

Circuit Diagram

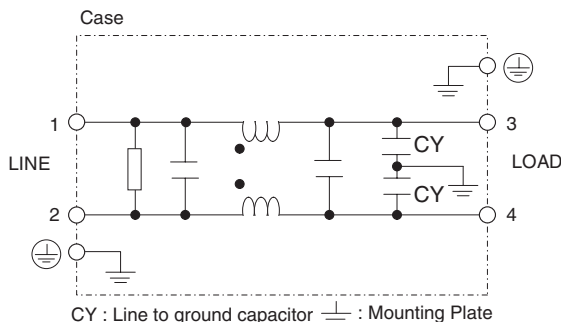

Derating Curve

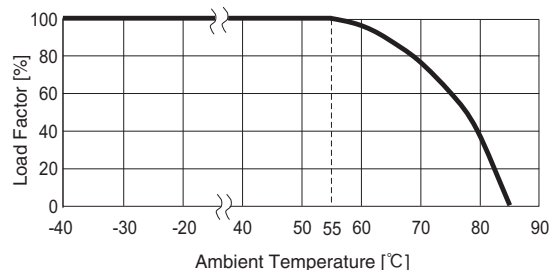

External view

This product is shipped in the following condition, because it is equipped with push-down terminals.

- ① The terminal cover is retracted inside the unit.
- ② The screws for connecting the terminals are held in the up right position.

Standard Type

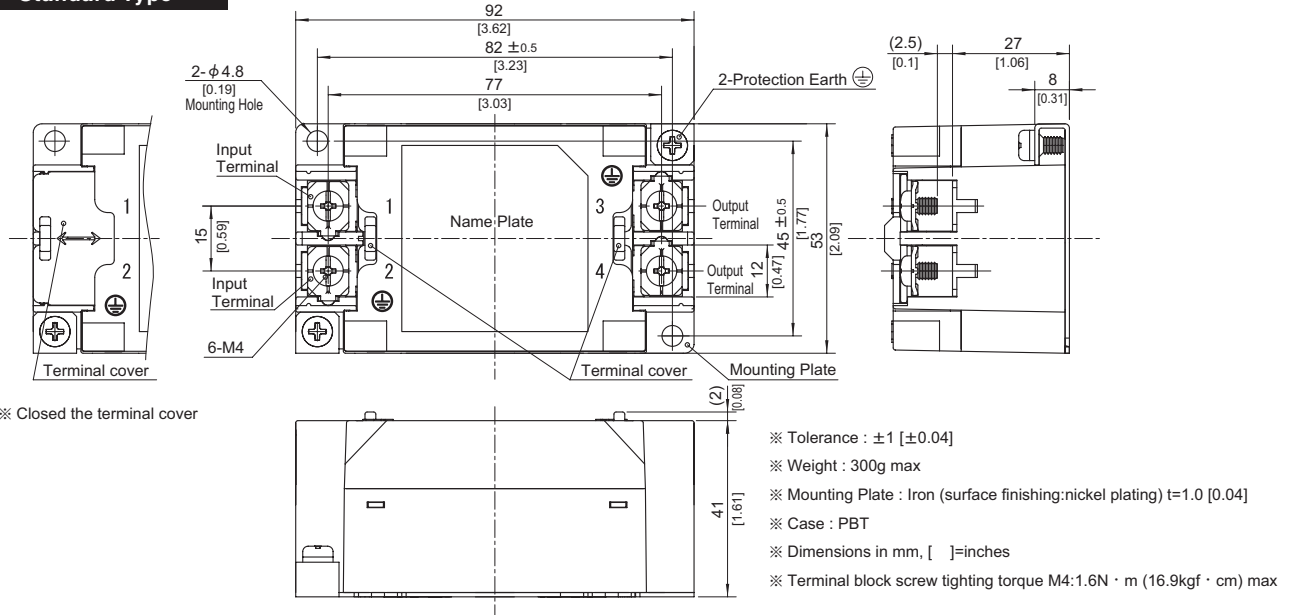

DIN rail installation Type

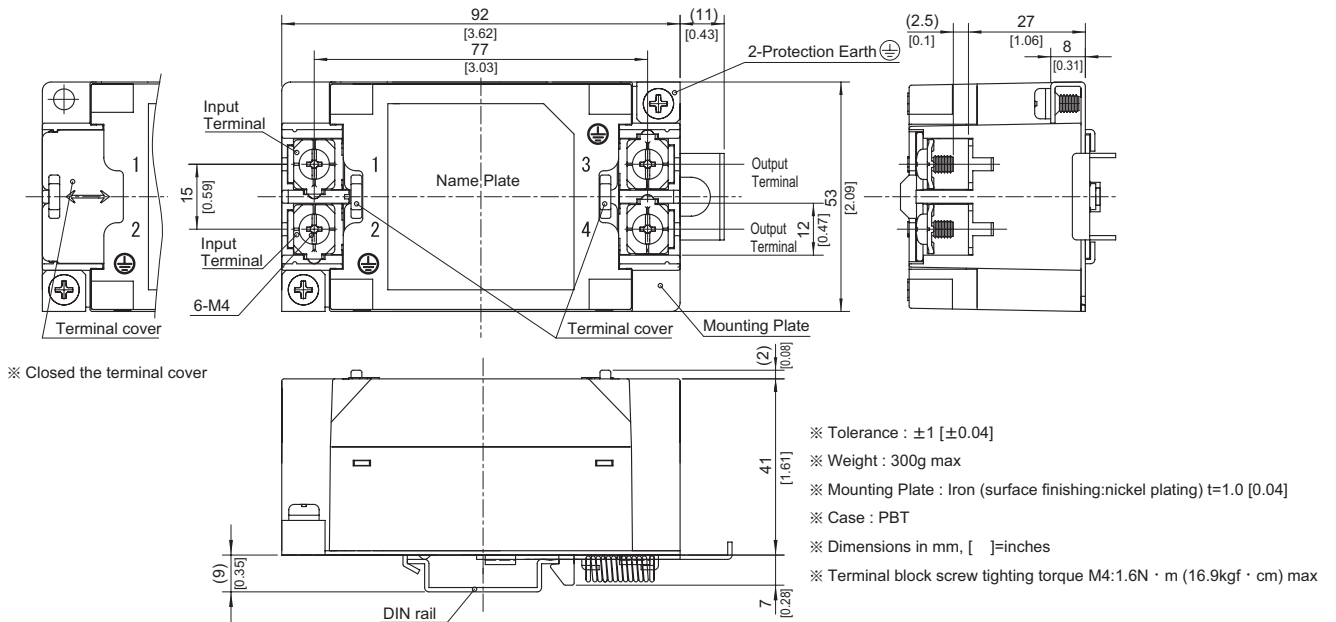

■Note when installing the EMI/EMC Filter on a DIN rail.

When the EMI/EMC Filter is grounded through the DIN rail, the proper noise attenuation may not be achieved.

Be sure to connect the protection earth (PE) of the EMI/EMC Filter body to the earth. At least one PE connection is required.

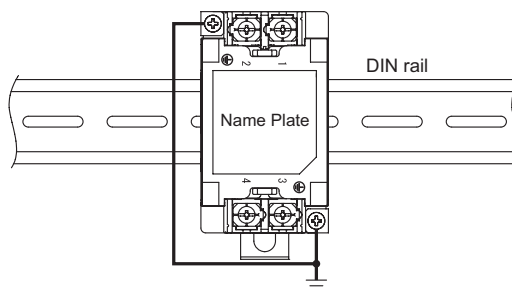

NAC-06-472

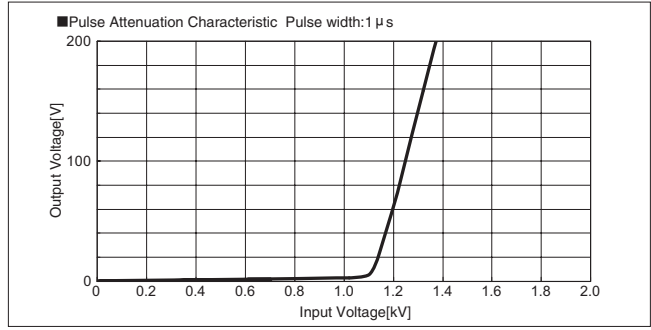
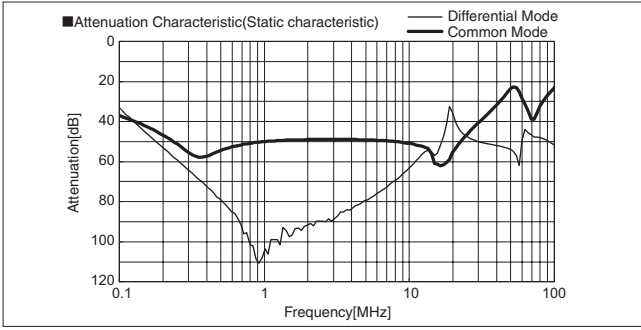

NAC-10-472

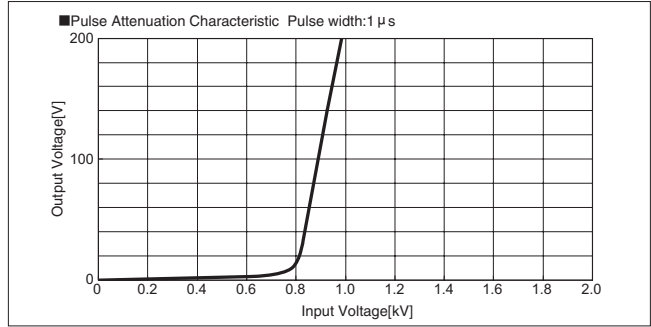
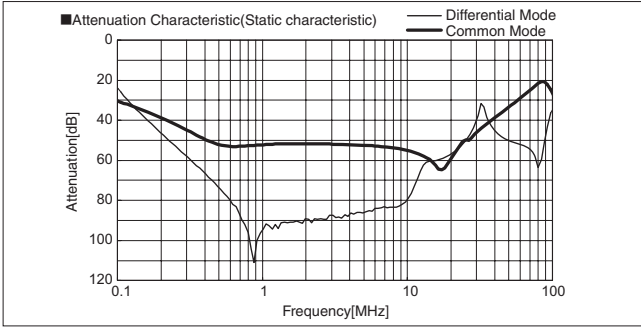

NAC-16-472

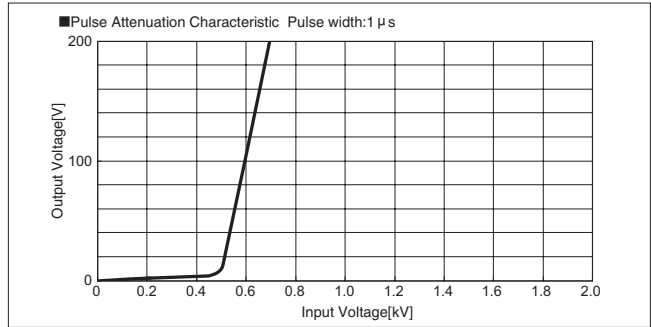
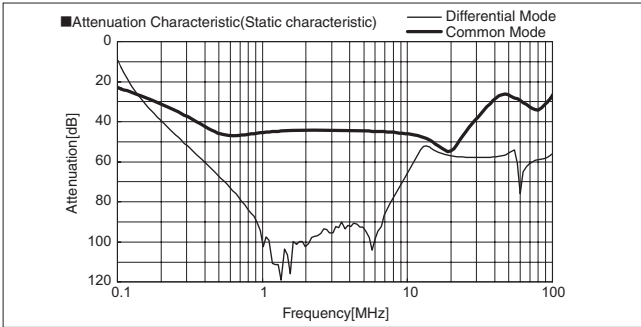

NAC-20-472

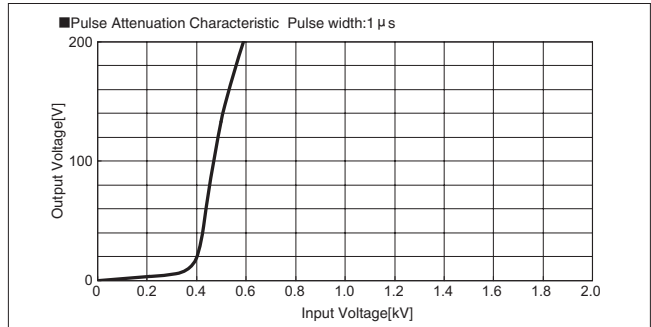
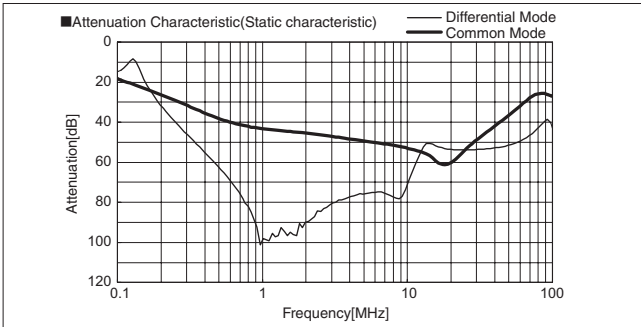

NAC-30-472

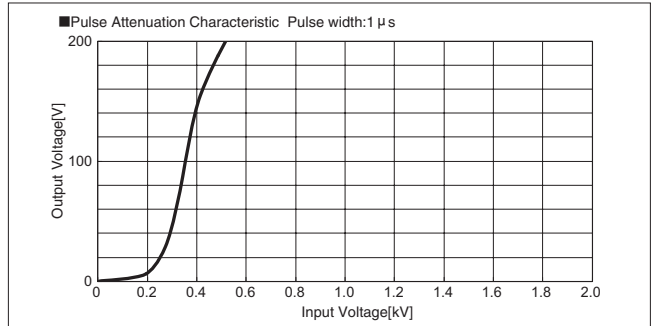
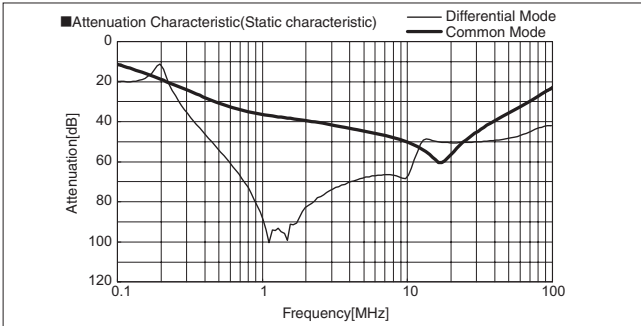

■Characteristic example of conductive noise reduction.

Reference data (PBA150F-5-G : Low leakage current type)

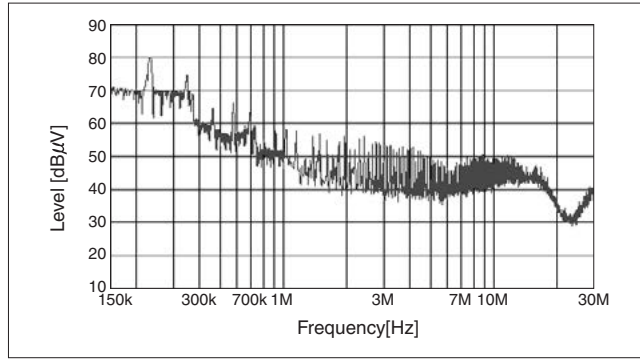

NAC-06-472+PBA150F-5-G

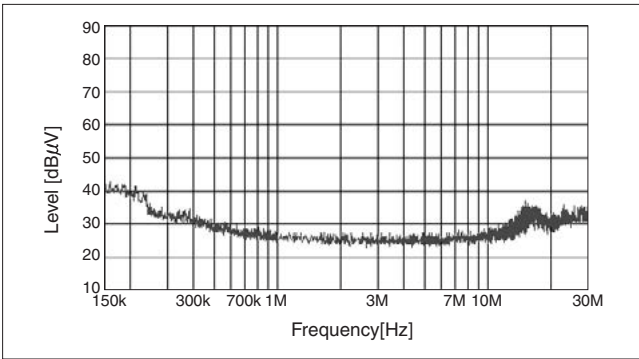

NAC-10-472+PBA150F-5-G

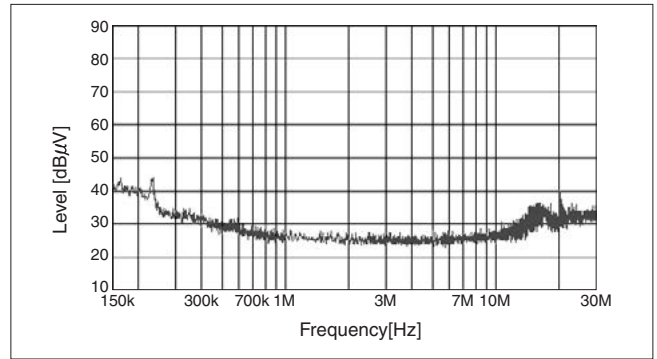

NAC-16-472+PBA150F-5-G

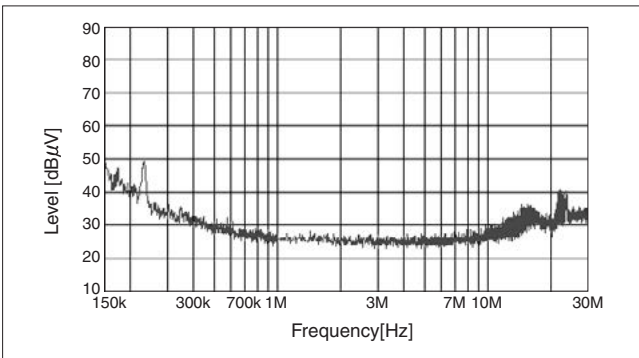

NAC-20-472+PBA150F-5-G

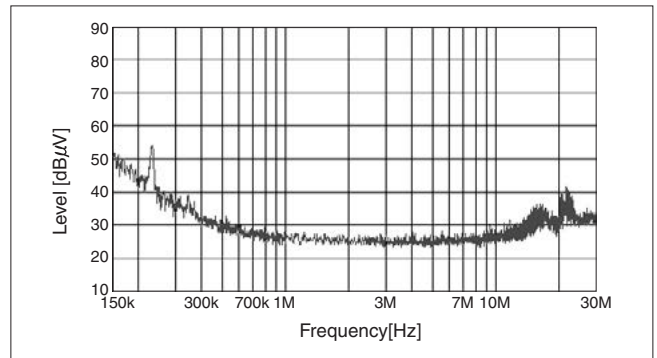

NAC-30-472+PBA150F-5-G

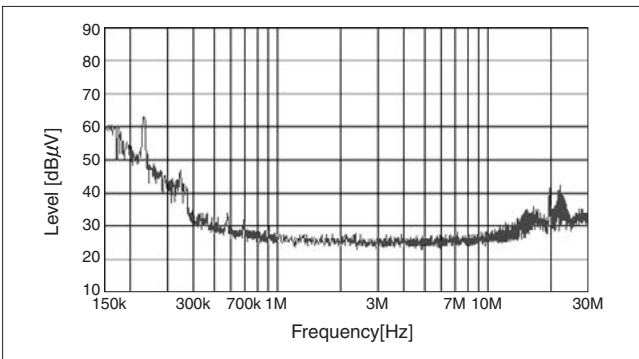

Condition : 230 VAC, I_o=100%

NAM-06-000

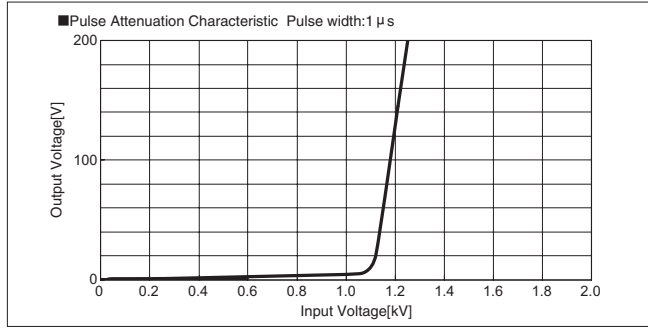
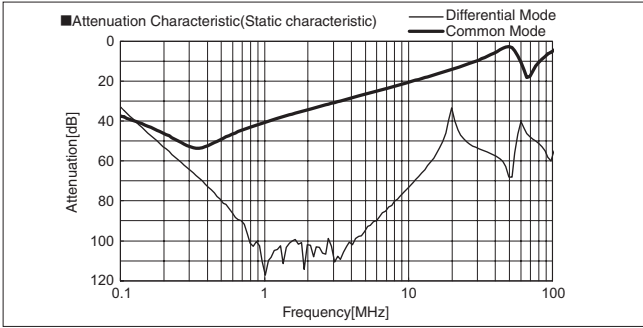

NAM-10-000

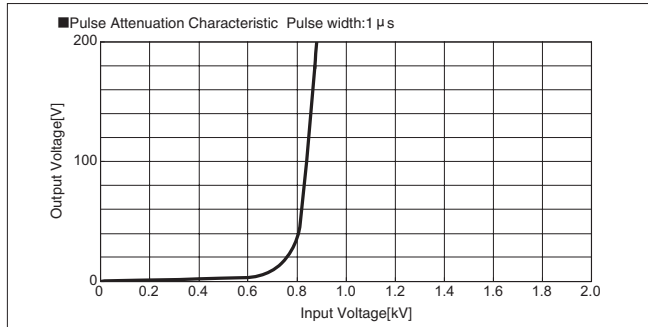
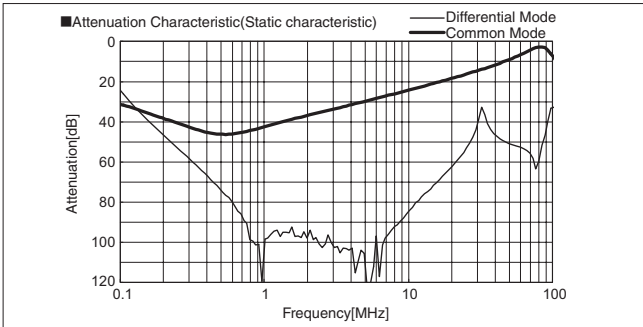

NAM-16-000

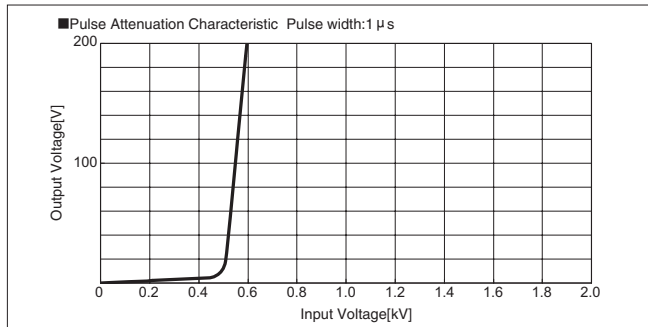
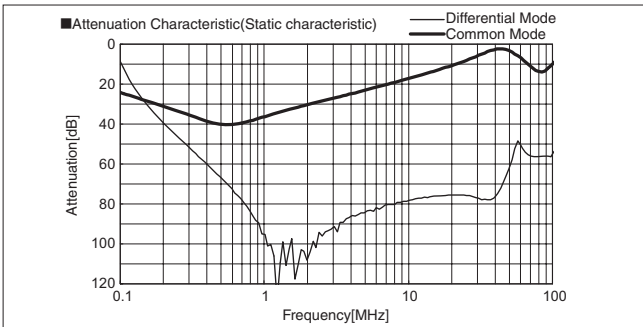

NAM-20-000

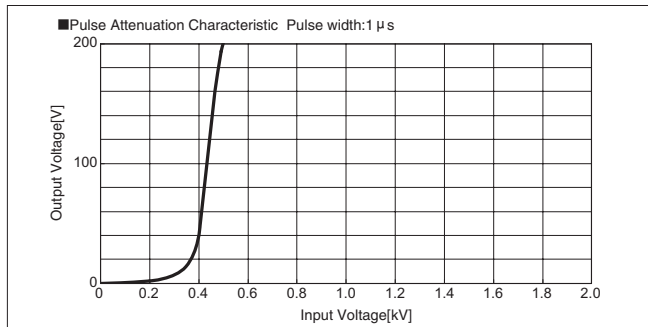
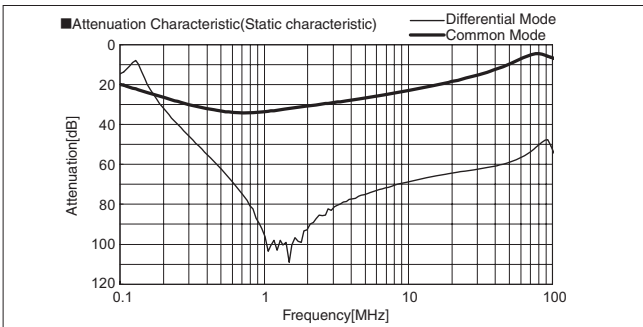

NAM-30-000

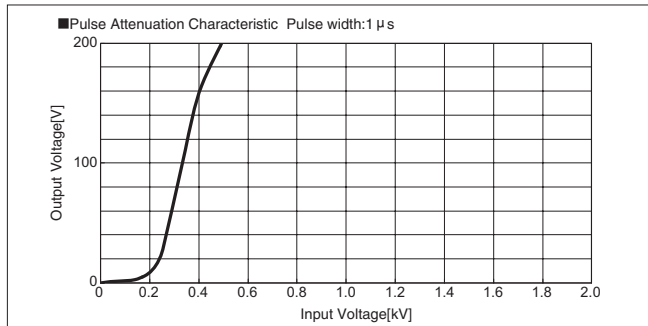
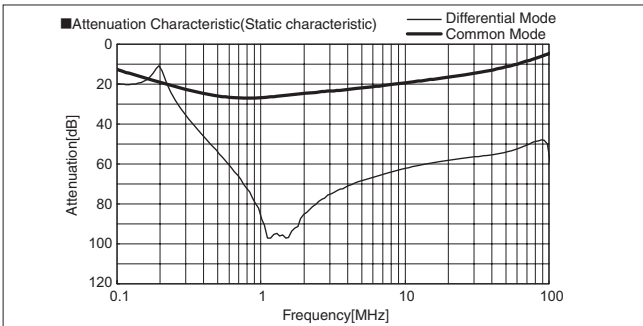

NAH-06-472

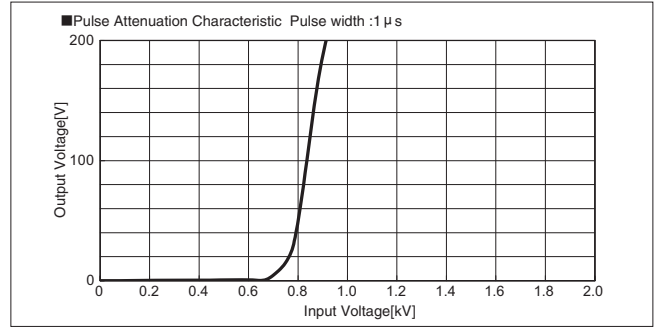
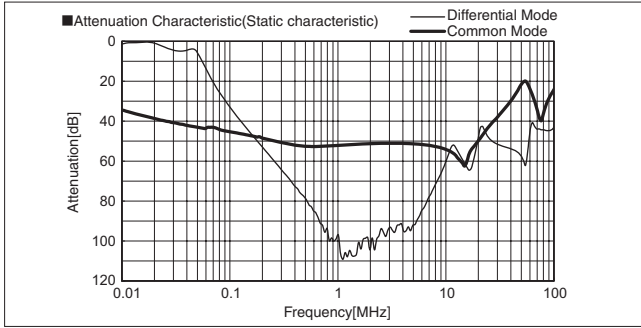

NAH-10-472

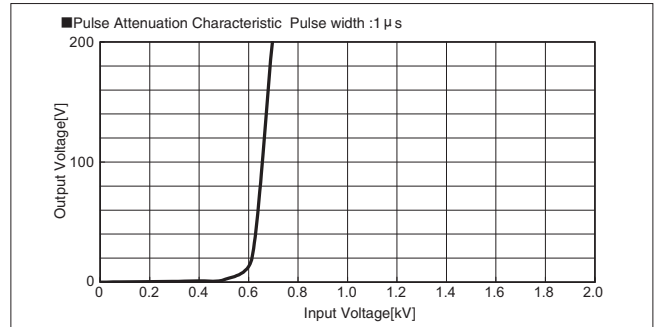
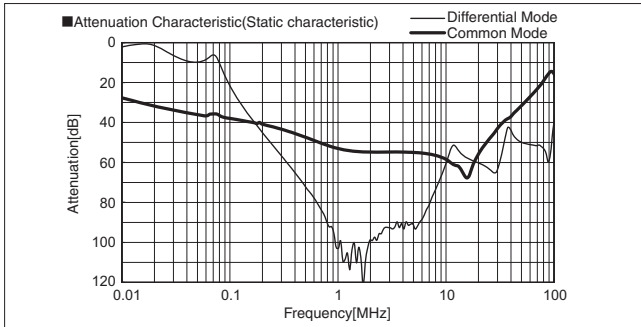

NAH-16-472

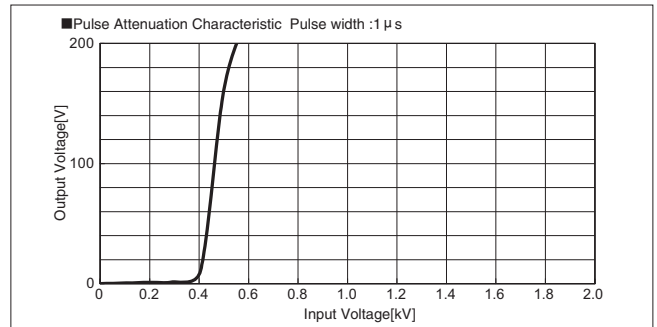
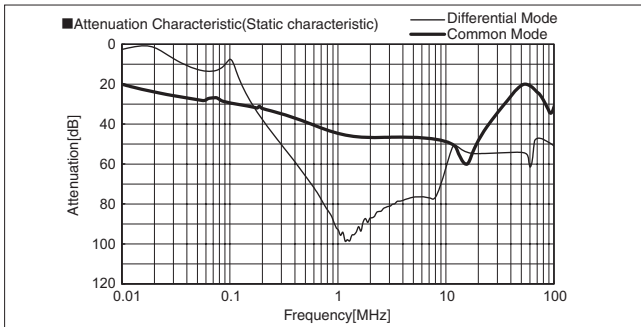

NAH-20-472

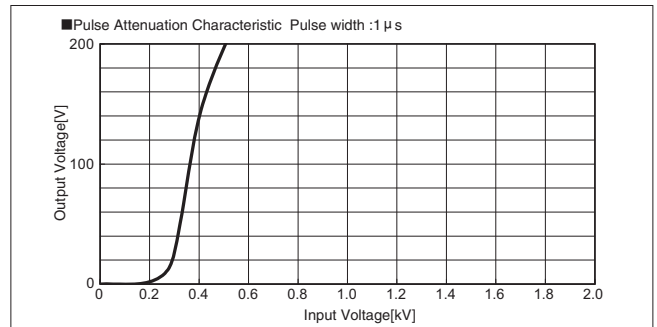
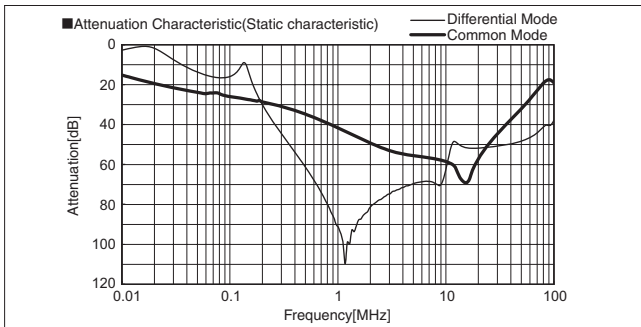

NAH-30-472

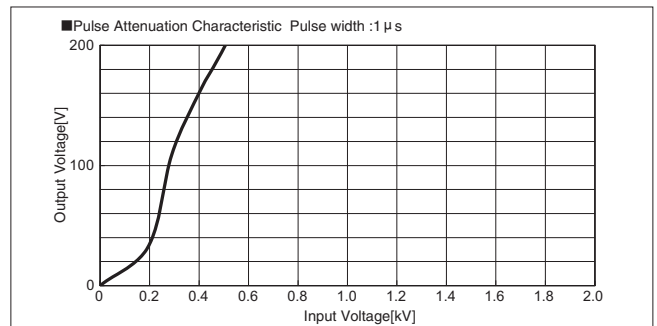
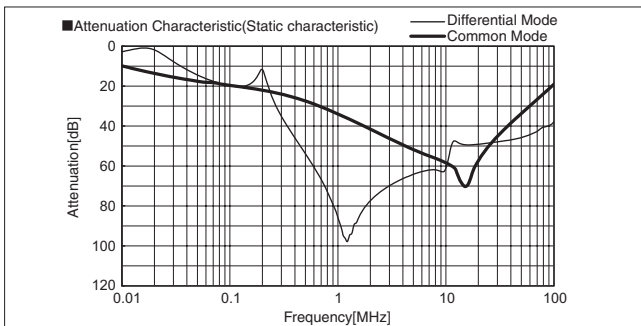

NAP-06-472

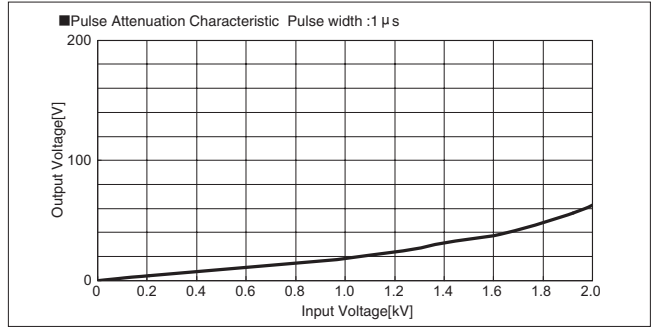
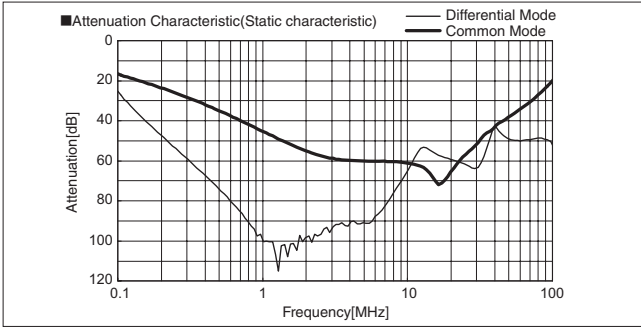

NAP-10-472

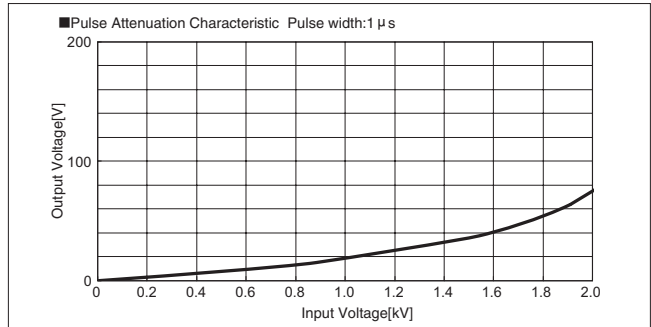
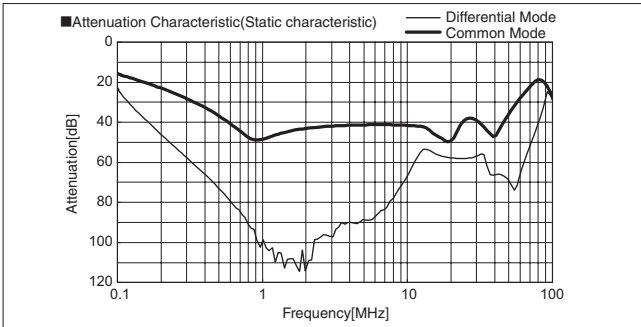

NAP-16-472

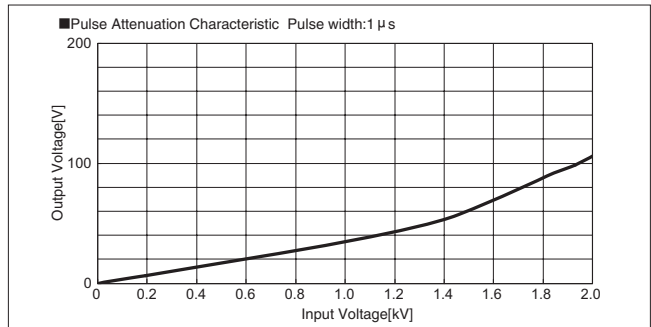
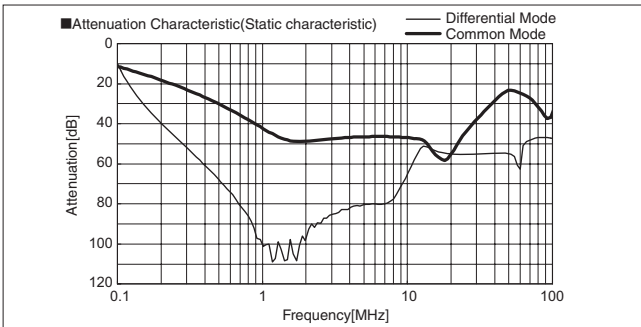

NAP-20-472

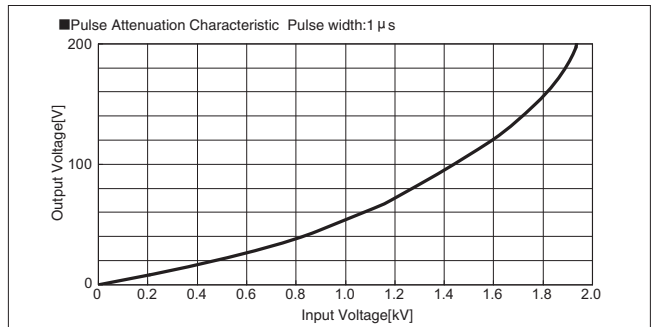
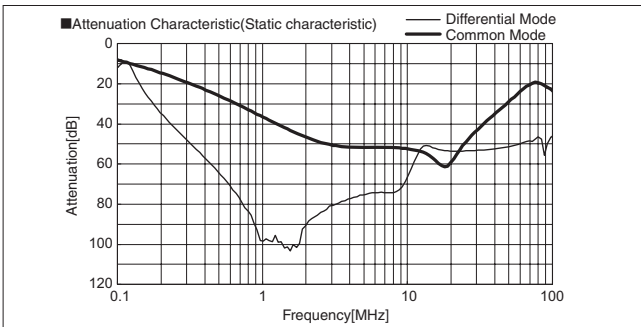

NAP-30-472

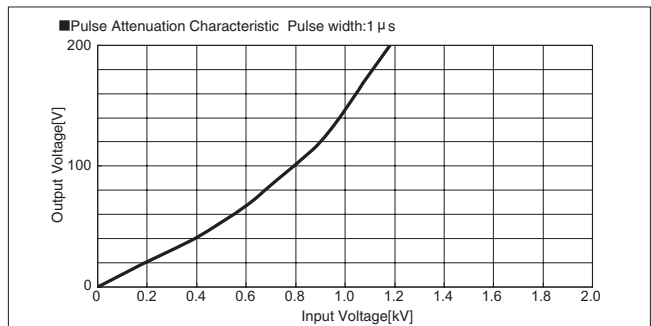
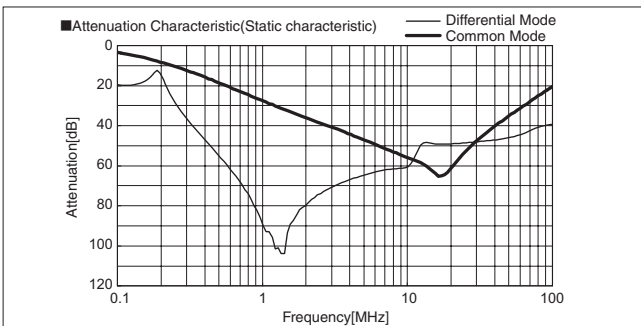

Circuit Diagram

(1) Line to ground capacitor code :000,471,222,472,223

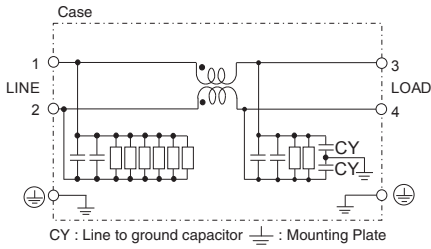

(2) Line to ground capacitor code :683

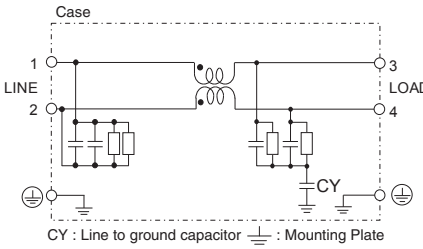

(3) Line to ground capacitor code :224,155

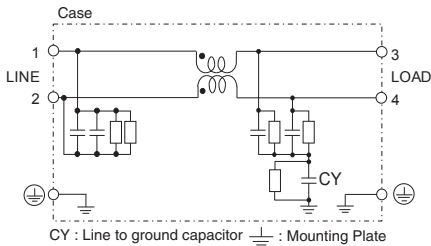

(4) Line to ground capacitor code :103,223,683
Option : F

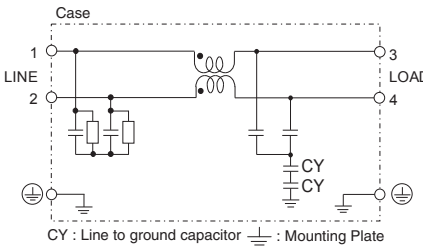

Derating Curve

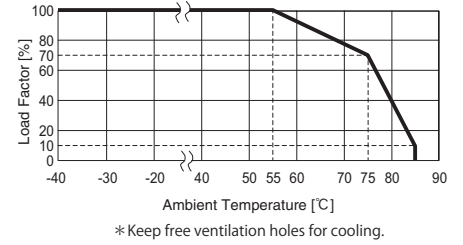

External view

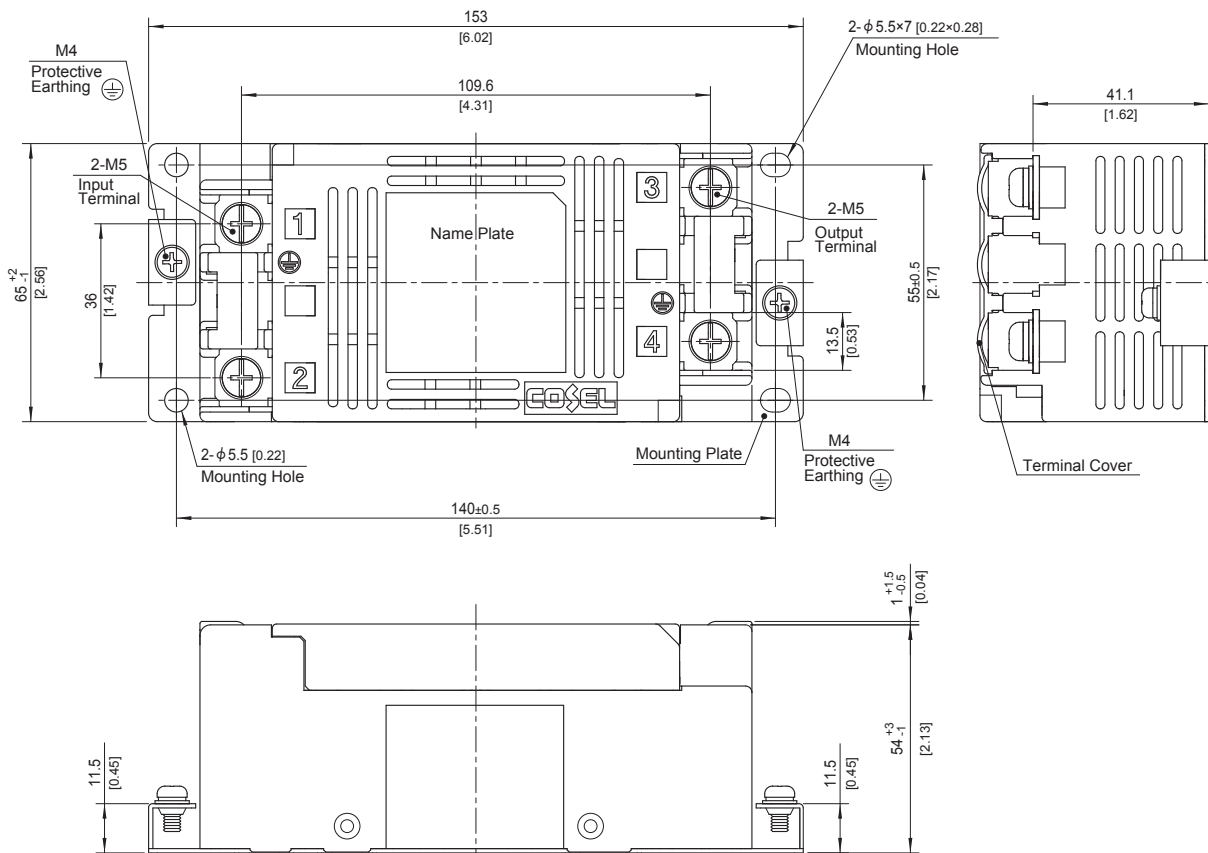

- ※ Dimensions in mm, []=inches
- ※ Tolerance: ± 1 [± 0.04]
- ※ Weight: 750g max
- ※ Mounting Plate: Hot-dip Galvanized Steel board $t=1.0$ [0.04]
- ※ Case Material: PBT
- ※ Terminal block screw tightening torque M5: 3.0N·m max
- ※ Protective Earthing (PE) screw tightening torque M4 : 1.6N·m max
- ※ Can not be mounted upside-down. (mounted the top surface)
- ※ Keep free ventilation holes for cooling.
- ※ Can be mounted using the 2 corner mounting holes.

NAC-40-472

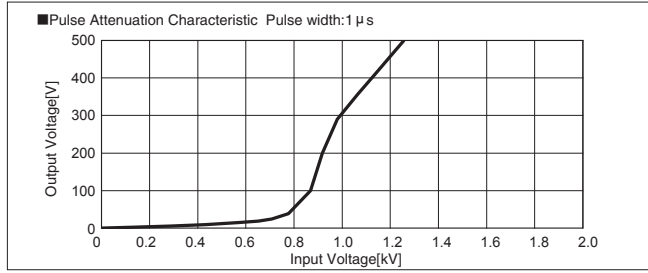
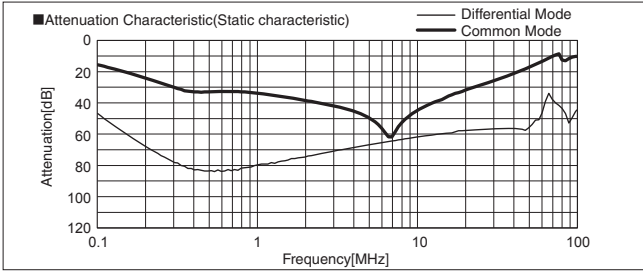

NAC-40-155

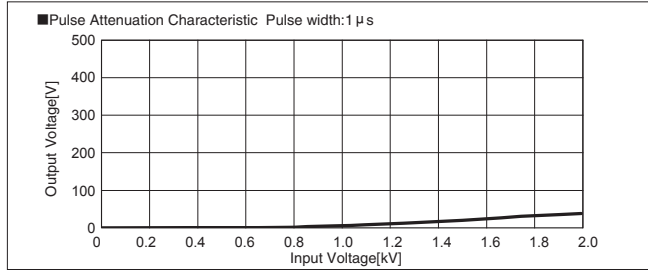
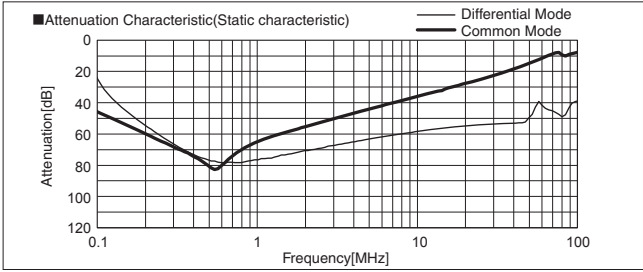

NAC-50-472

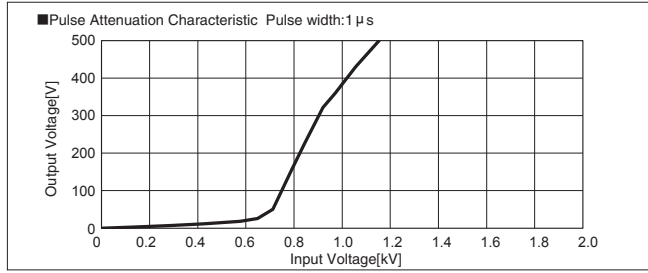
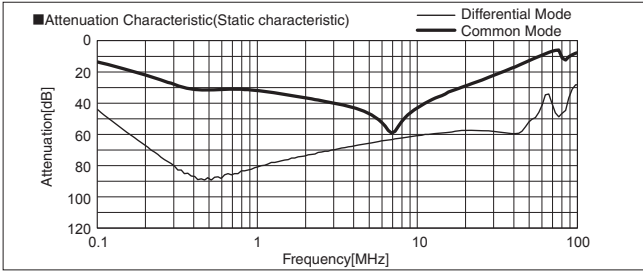

NAC-50-155

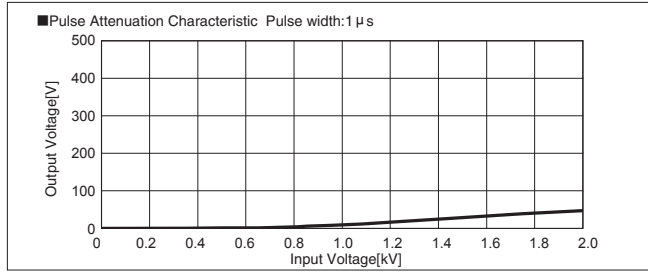
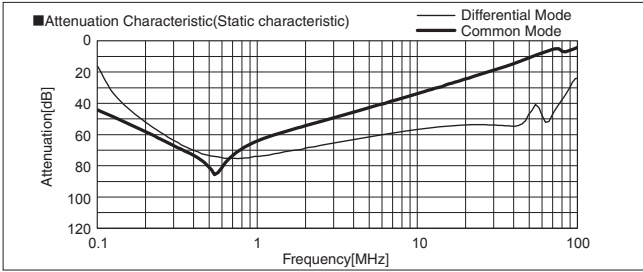

NAC-60-472

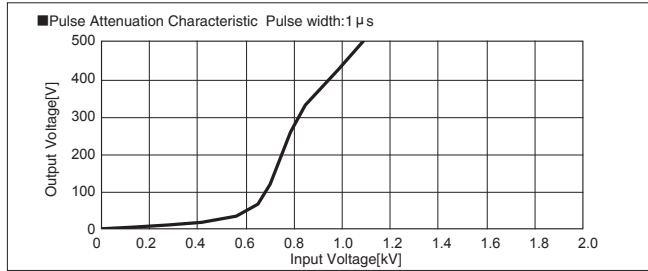
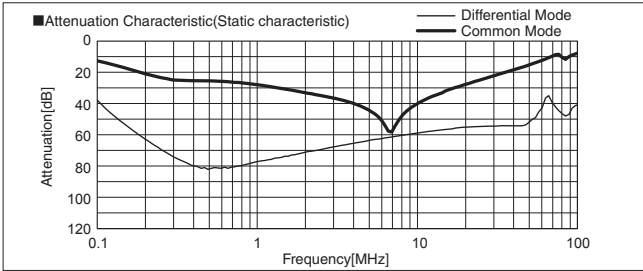

NAC-60-155

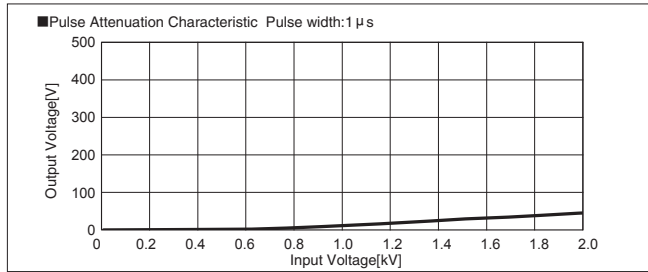
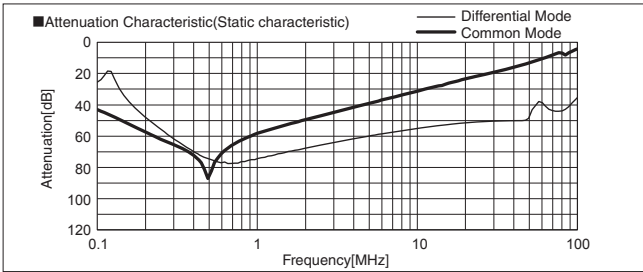

NAM-40-000

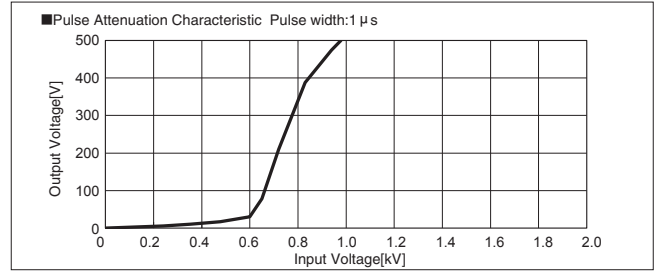
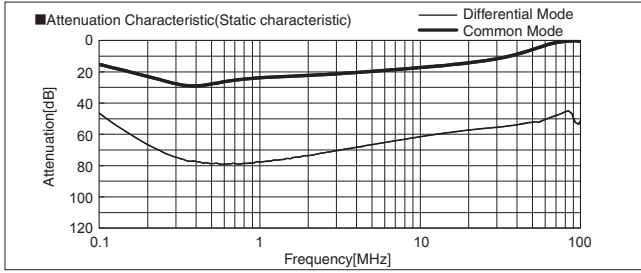

NAM-50-000

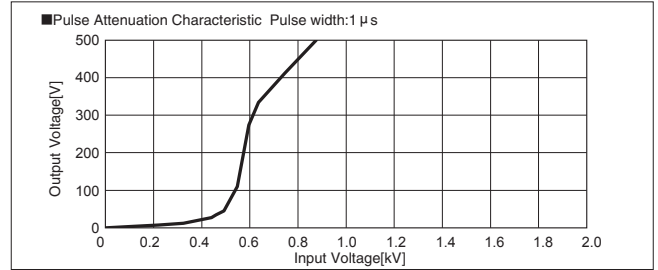
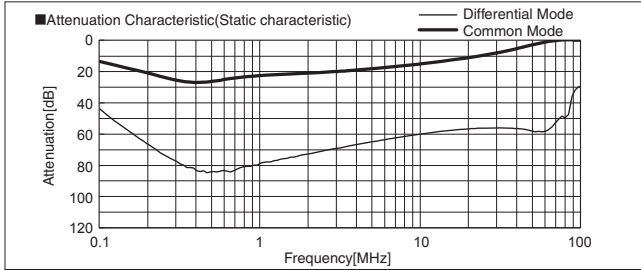

NAM-60-000

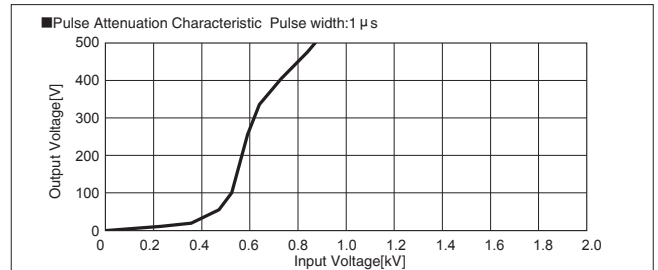
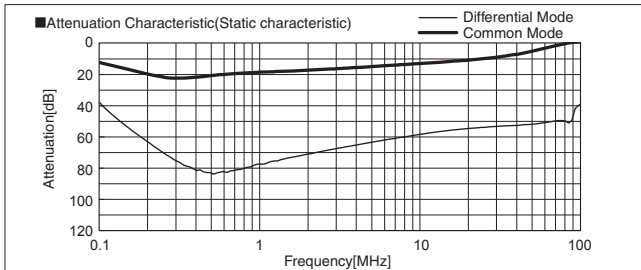

NAH-40-472

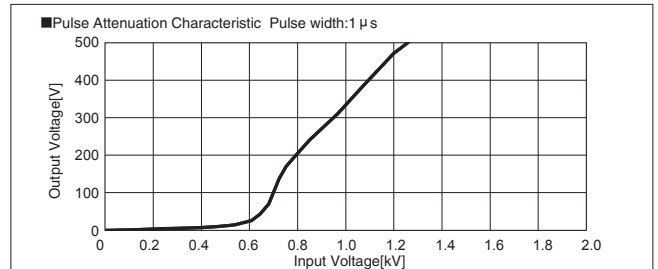
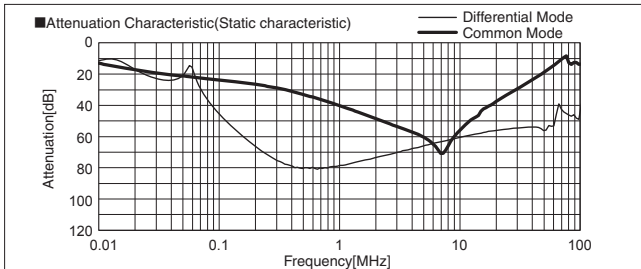

NAH-50-472

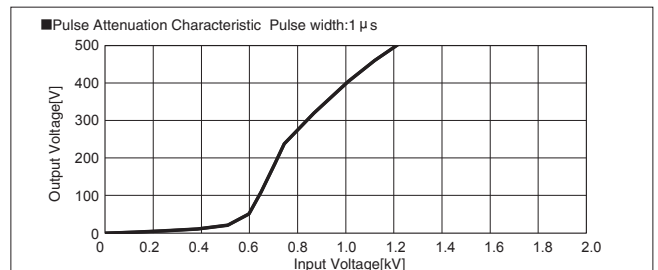
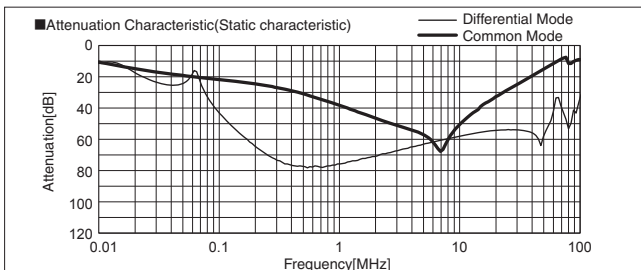

NAH-60-472

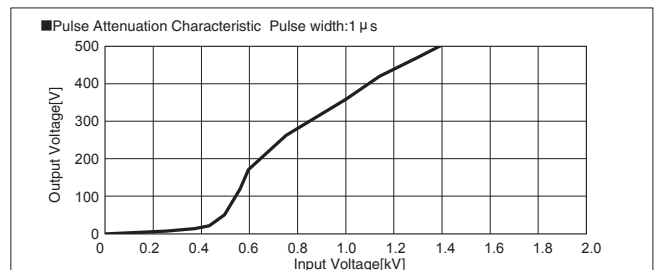
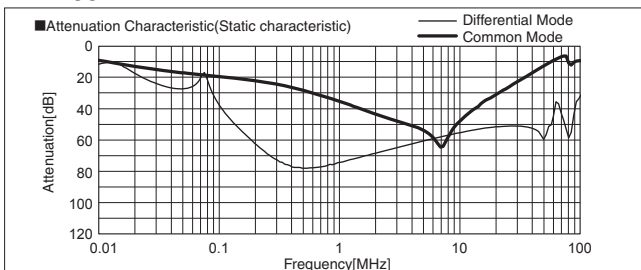

NAP-40-472

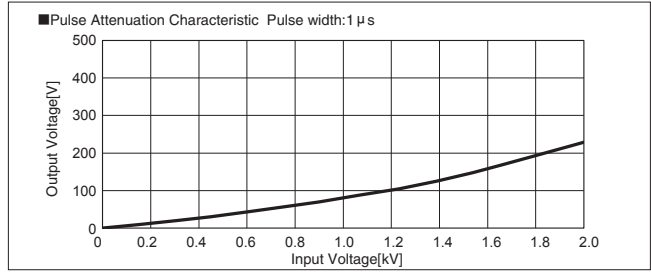
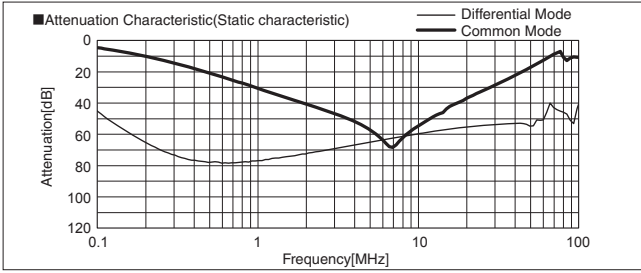

NAP-50-472

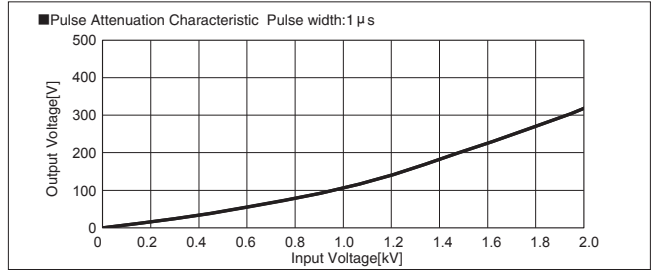
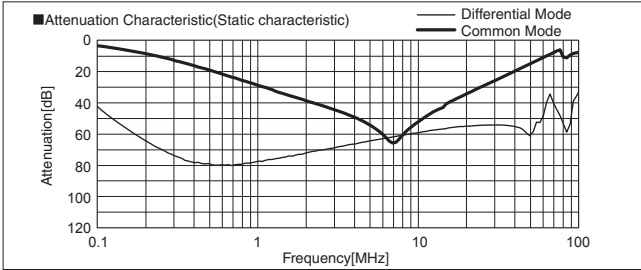

NAP-60-472

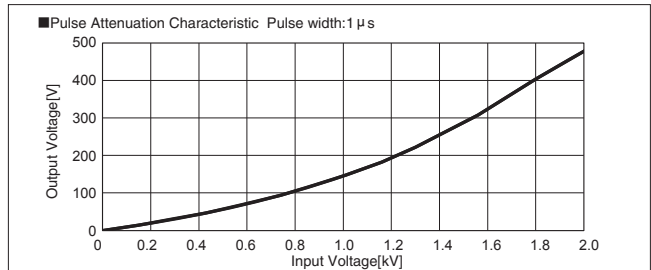
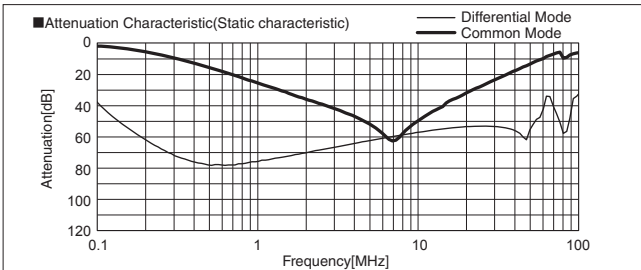

NAC-40-103-F

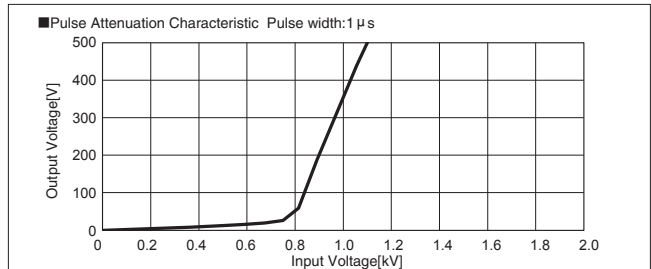
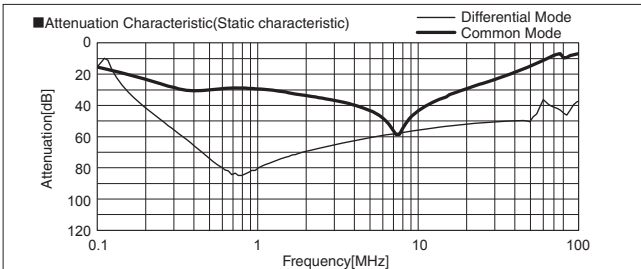

NAC-50-103-F

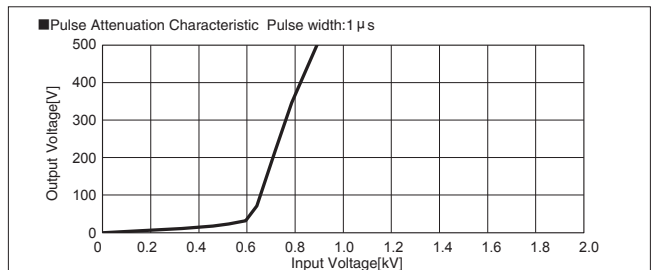
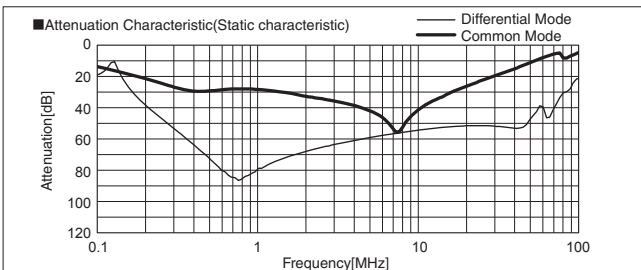

NAC-60-103-F

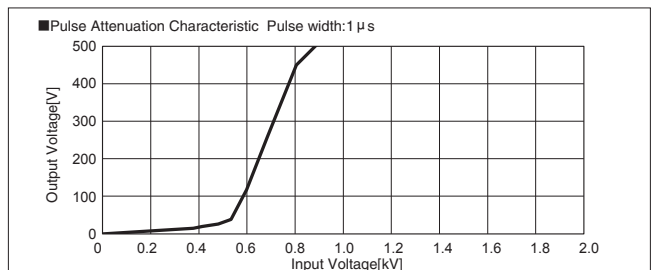
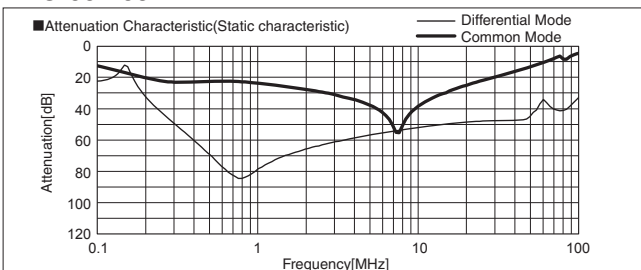

NAH-40-103-F

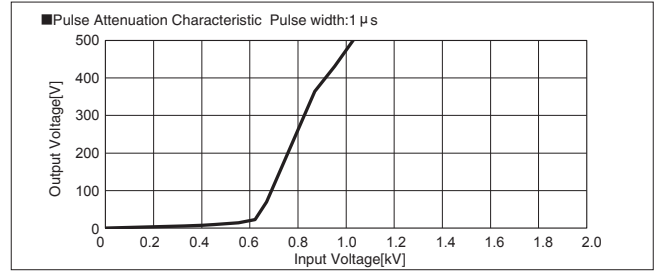
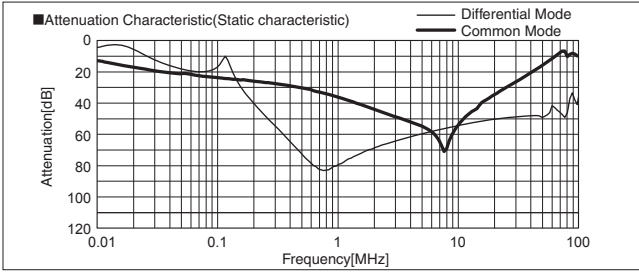

NAH-50-103-F

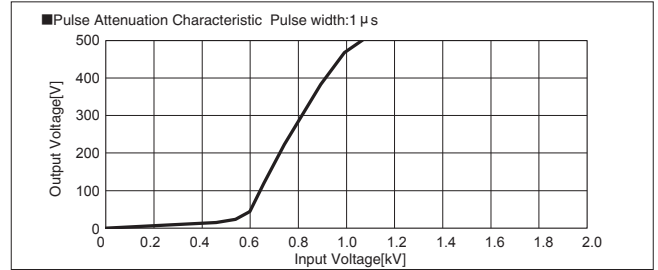
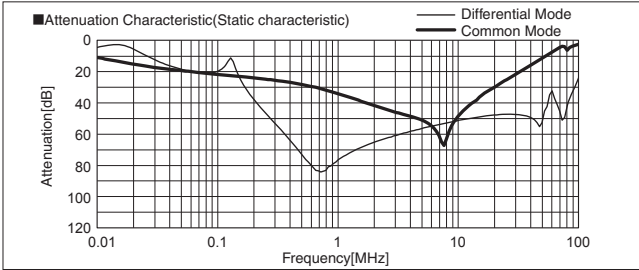

NAH-60-103-F

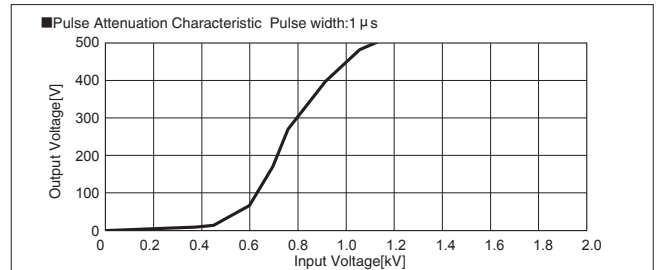
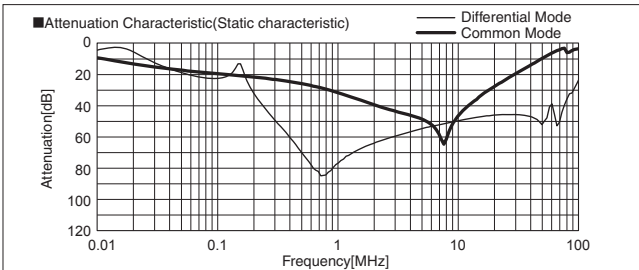

NAP-40-103-F

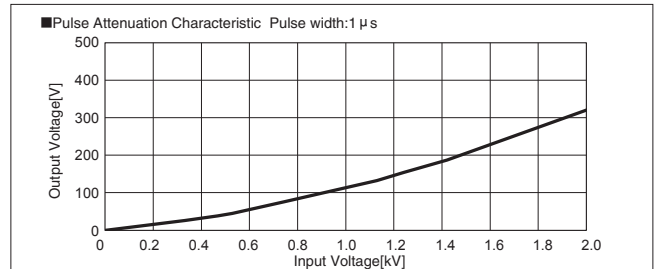
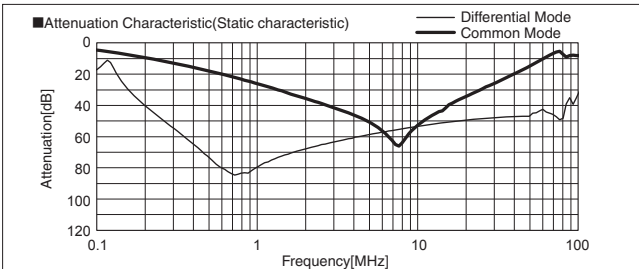

NAP-50-103-F

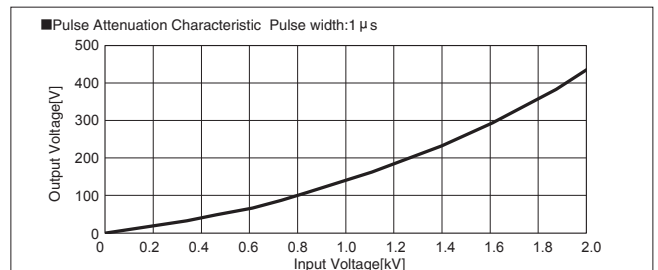
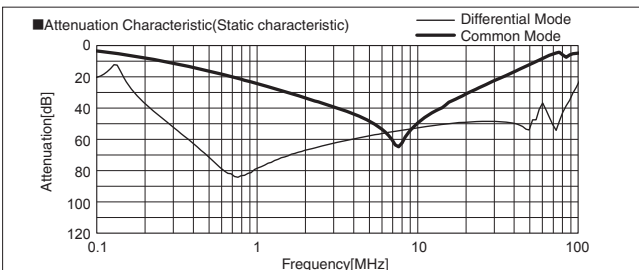

NAP-60-103-F

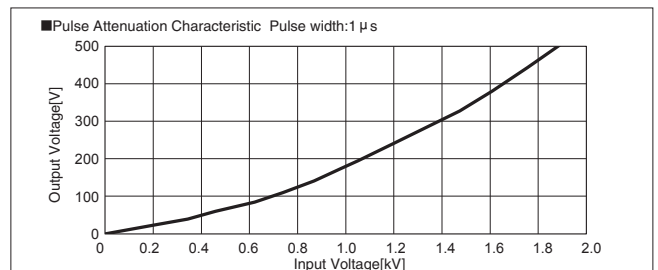
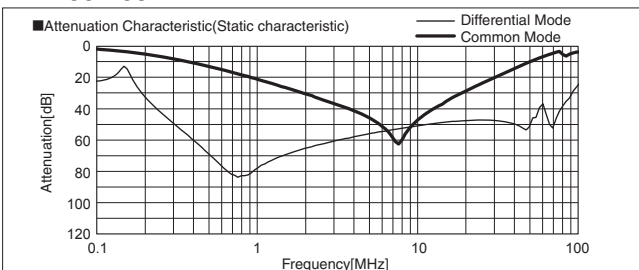

NBH series

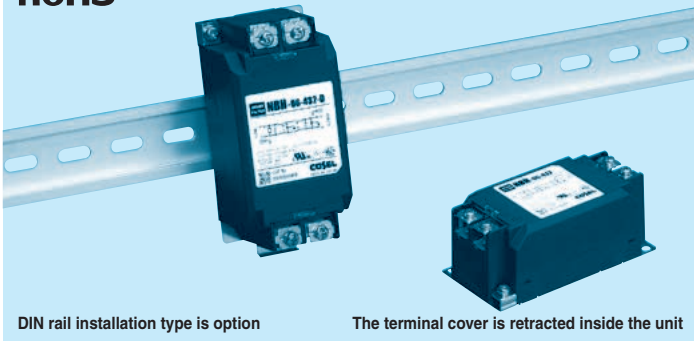

DIN rail installation type is option

The terminal cover is retracted inside the unit

Ordering information

NBH -10 -432 -□

- ① Model Name
- ② Rated Current
- ③ Line to ground capacitor code: Refer to table 1.1.

table 1.1 Line to ground capacitor code

Code	Leakage Current (Input 125/250V 60Hz)	Line to ground capacitor (nominal value)		Test voltage (Terminal- Mounting Plate)
		CY1	CY2	
000	5 μ A/ 10 μ A max	Not Provided	Not Provided	4,000VAC
101	12.5 μ A/ 25 μ A max	100pF	Not Provided	
221	25 μ A/ 50 μ A max	220pF	Not Provided	
331	37.5 μ A/ 75 μ A max	330pF	Not Provided	
471	50 μ A/100 μ A max	470pF	Not Provided	
681	75.5 μ A/150 μ A max	680pF	Not Provided	2,500VAC
102	0.13mA/0.25mA max	1000pF	Not Provided	
202	0.25mA/0.5 mA max	1000pF	1000pF	
322	0.38mA/0.75mA max	2200pF	1000pF	
432	0.5 mA/1.0 mA max	3300pF	1000pF	

* When the line to ground capacitor code is different, the attenuation characteristic is different.

- ④ Option
- D: DIN rail installation type

* The dimensions change when the option is set. Refer to External view.

Features of NBH series

Ultra high-attenuation type from 9kHz to 10MHz (2-Stage filter)

- Single Phase 250VAC
- Withstand voltage 4,000 VAC (Line to ground capacitor code -000 to -471)
- Quick and easy push-down terminal

Just connect the wires, push-down and tighten the screws with a screwdriver

Specifications

No.	Items	NBH-06-432	NBH-10-432	NBH-16-432	NBH-20-432	NBH-30-432
1	Rated Voltage[V]	AC 1 ϕ 250 / DC250				
2	Rated Current[A]	6	10	16	20	30
3	Test Voltage (Terminal-Mounting Plate) *1	2,500 VAC (Cutoff Current = 20mA), 1minute at room temperature and humidity				
4	Isolation Resistance (Terminal-Mounting Plate)	500 VDC 100M Ω min at room temperature and humidity				
5	Leakage current 125/250V 60Hz	0.5mA/1.0mA max				
6	Voltage drop	1.0V max				
7	Safety agency approval temperatures	-25 to +85°C (Refer to Derating Curve A)		-25 to +85°C (Refer to Derating Curve B)		
8	Operating temperature	-40 to +85°C (Refer to Derating Curve A)		-40 to +85°C (Refer to Derating Curve B)		
9	Operating humidity	20 to 95%RH (Non condensing)				
10	Storage temperature/humidity	-40 to +85°C/20 to 95%RH (Non condensing)				
11	Vibration	10 to 55Hz, 19.6m/s ² (2G), 3min. Period, 1hour each X, Y and Z axis				
12	Impact	196.1m/s ² (20G), 11ms Once each X, Y and Z axis				
13	Safety agency approvals	UL1283, CSA C22.2 No.8 (C-UL), DIN EN60939 VDE0565 Teil3-1, ENEC (At only AC input)				
14	Case size (without projection) /Weight	53X43X104 mm [2.09X1.69X4.09 inches] (W X H X D) /320g max (Option : -D refer to external view)				

*1 When the line to ground capacitor code is different, the test voltage characteristic is different. (Refer to table 1.1)

Circuit Diagram

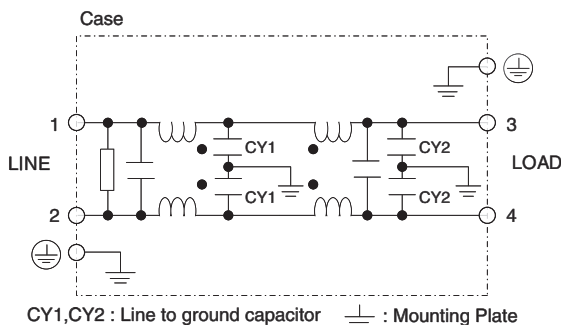

Derating Curve

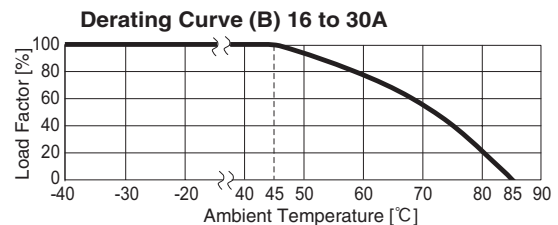
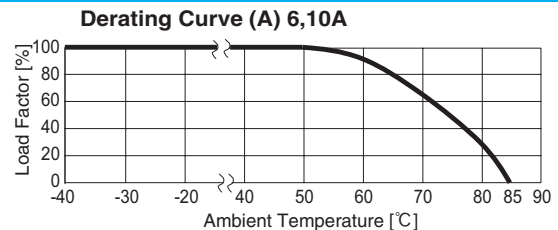

External view

This product is shipped in the following condition, because it is equipped with push-down terminals.

- ① The terminal cover is retracted inside the unit.
- ② The screws for connecting the terminals are held in the up right position.

Standard Type

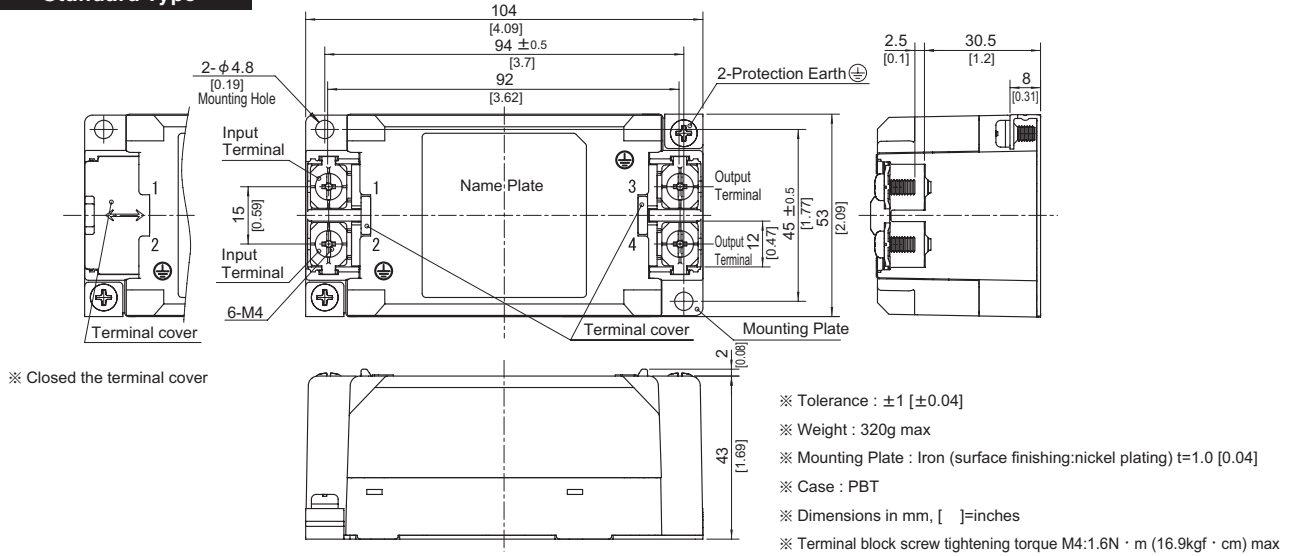

DIN rail installation Type

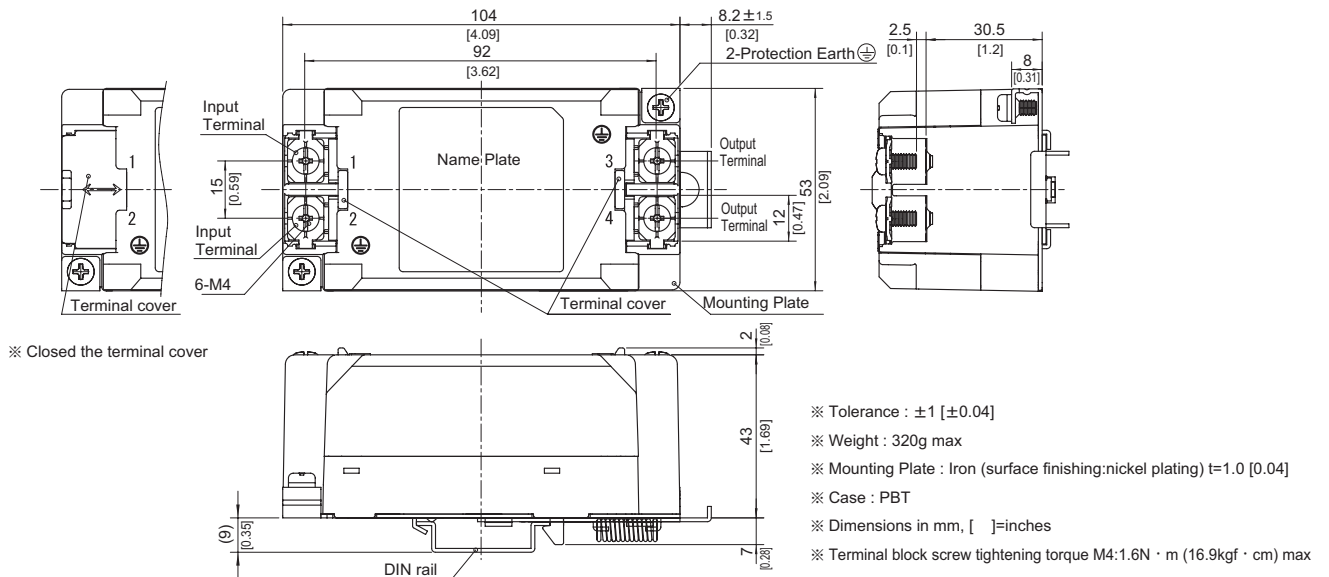

■Note when installing the EMI/EMC Filter on a DIN rail.

When the EMI/EMC Filter is grounded through the DIN rail, the proper noise attenuation may not be achieved.

Be sure to connect the protection earth (PE) of the EMI/EMC Filter body to the earth. At least one PE connection is required.

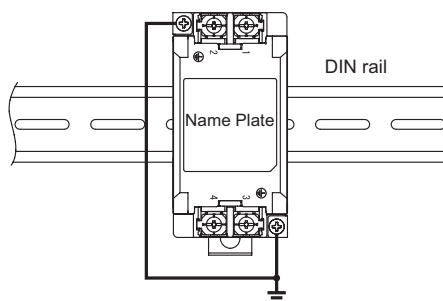

NBC/NBM series

NBC -10 -472 -□

① ② ③ ④

- ① Series Name
- ② Rated Current
- ③ Line to ground capacitor code: Refer to table 1.1.

table.1.1 Line to ground capacitor code

Code	NBC	NBM	Leakage Current (Input 125/250V 60Hz)	Line to ground capacitor (nominal value)
000			5 μ A / 10 μ A max	Not Provided
101	●		12.5 μ A / 25 μ A max	100pF
221	●		25 μ A / 50 μ A max	220pF
331	●		37.5 μ A / 75 μ A max	330pF
471	●		50 μ A / 100 μ A max	470pF
681	●		75.5 μ A / 150 μ A max	680pF
102	●		0.13 mA / 0.25mA max	1,000pF
222	●		0.25 mA / 0.5 mA max	2,200pF
332	●		0.38 mA / 0.75mA max	3,300pF
472	●		0.5 mA / 1.0 mA max	4,700pF

* When the line to ground capacitor code is different, the attenuation characteristic is different.

- ④ Option
- D: DIN rail installation type

* The dimensions change when the option is set. Refer to External view.

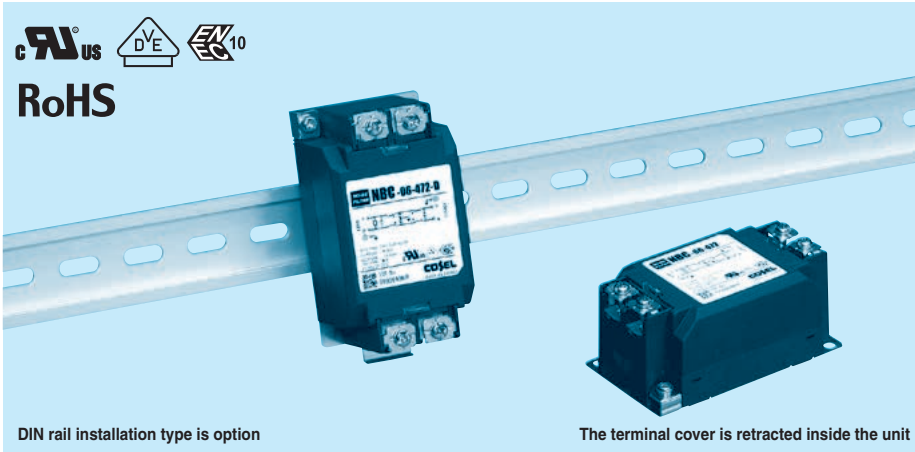

DIN rail installation type is option

The terminal cover is retracted inside the unit

Features of NBC/NBM series

- Single Phase 250VAC (2-Stage filter)
 - Quick and easy push-down terminal
- Just connect the wires, push-down and tighten the screws with a screwdriver

- NBC : High-attenuation type from 150kHz to 1MHz
- NBM : Low leakage current, Withstand voltage 4,000 VAC

Specifications

No.	Items	NBC-06-472	NBC-10-472	NBC-16-472	NBC-20-472	NBC-30-472
		NBM-06-471	NBM-10-471	NBM-16-471	NBM-20-471	NBM-30-471
1	Rated Voltage[V]	AC 1 ϕ 250 / DC250				
2	Rated Current[A]	6	10	16	20	30
3	Test Voltage (Terminal-Mounting Plate)	NBC : 2,500 VAC (Cutoff Current = 20mA), 1minute at room temperature and humidity NBM : 4,000 VAC (Cutoff Current = 20mA), 1minute at room temperature and humidity				
4	Isolation Resistance (Terminal-Mounting Plate)	500 VDC 100M Ω min at room temperature and humidity				
5	Leakage current	Refer to table 1.1				
6	Voltage drop	1.0V max				
7	Safety agency approval temperatures	-25 to +85 $^{\circ}$ C (Refer to Derating Curve)				
8	Operating temperature	-40 to +85 $^{\circ}$ C (Refer to Derating Curve)				
9	Operating humidity	20 to 95%RH (Non condensing)				
10	Storage temperature/humidity	-40 to +85 $^{\circ}$ C/20 to 95%RH (Non condensing)				
11	Vibration	10 to 55Hz, 19.6m/s 2 (2G), 3min. Period, 1hour each X, Y and Z axis				
12	Impact	196.1m/s 2 (20G), 11ms Once each X, Y and Z axis				
13	Safety agency approvals	UL1283, CSA C22.2 No.8 (C-UL), DIN EN60939 VDE0565 Teil3-1, ENEC (At only AC input)				
14	Case size (without projection) /Weight	53X41X92 mm [2.09X1.61X3.62 inches] (W X H X D) /270g max (Option : -D refer to external view)				

Circuit Diagram

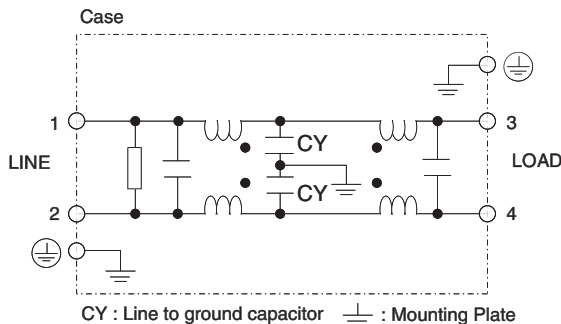

Derating Curve

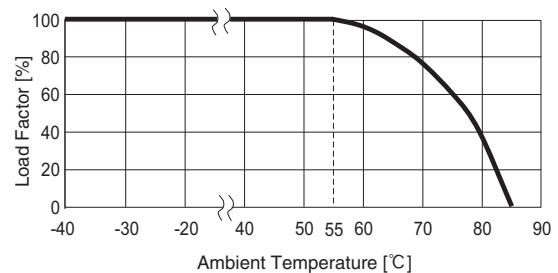

External view

This product is shipped in the following condition, because it is equipped with push-down terminals.

- ① The terminal cover is retracted inside the unit.
- ② The screws for connecting the terminals are held in the up right position.

Standard Type

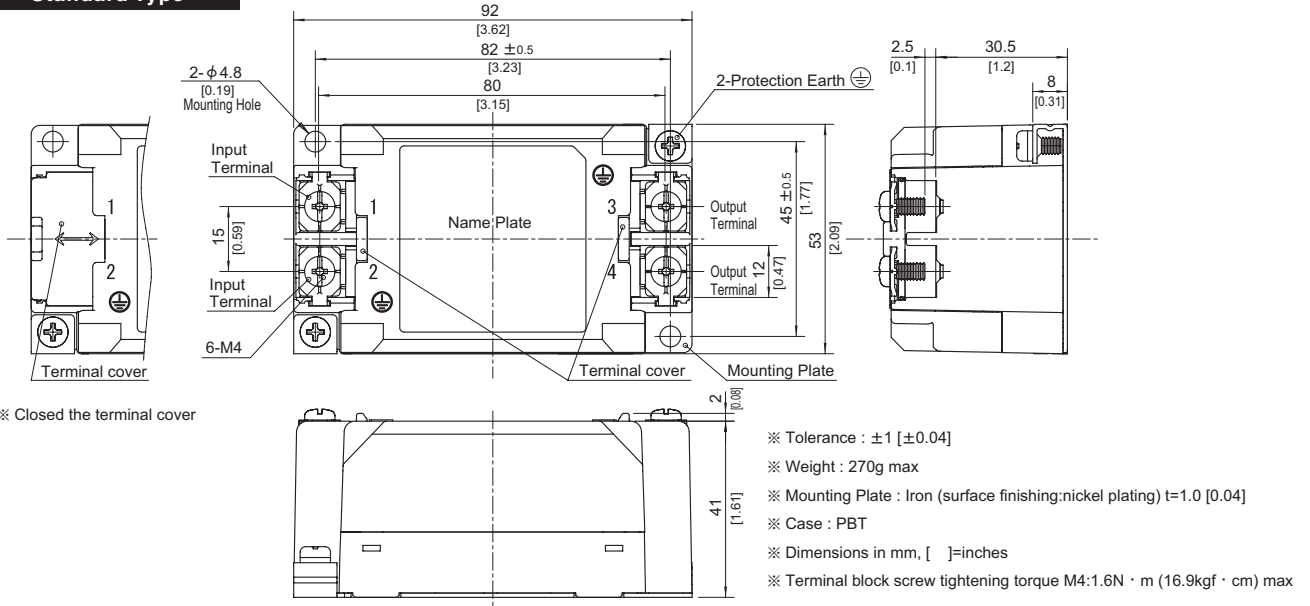

DIN rail installation Type

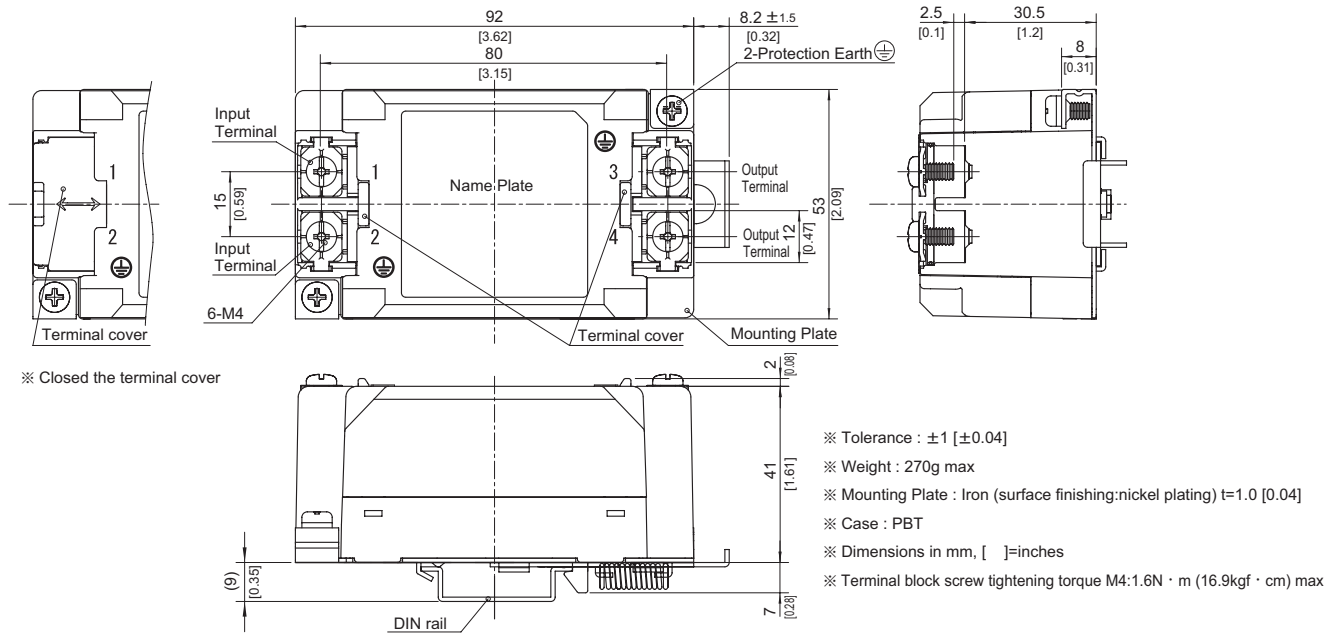

■ Note when installing the EMI/EMC Filter on a DIN rail.

When the EMI/EMC Filter is grounded through the DIN rail, the proper noise attenuation may not be achieved.

Be sure to connect the protection earth (PE) of the EMI/EMC Filter body to the earth. At least one PE connection is required.

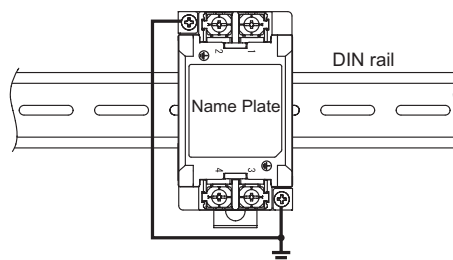

NBH-06-432

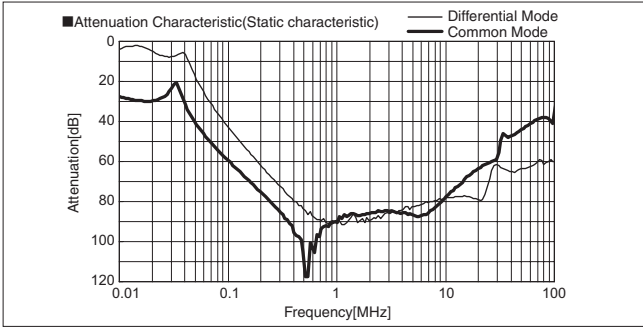

NBH-10-432

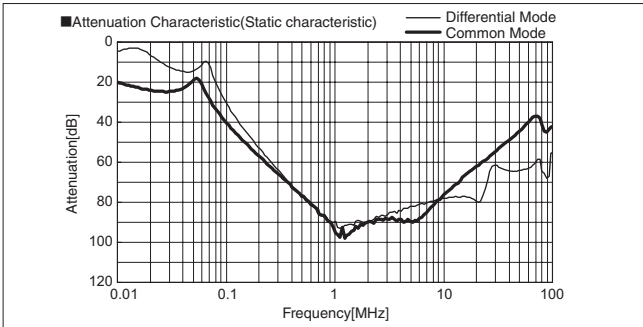

NBH-16-432

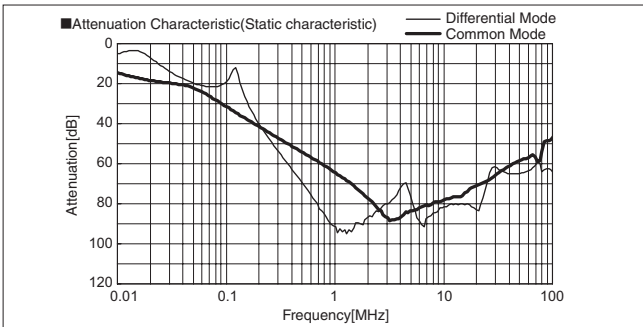

NBH-20-432

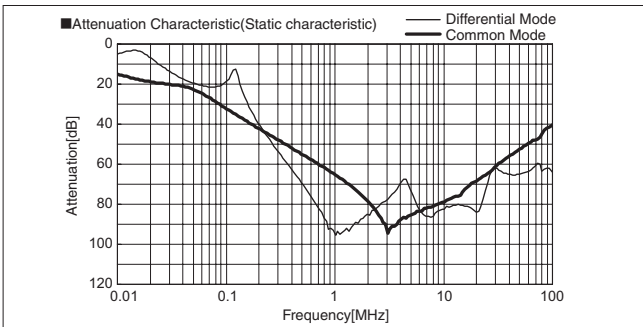

NBH-30-432

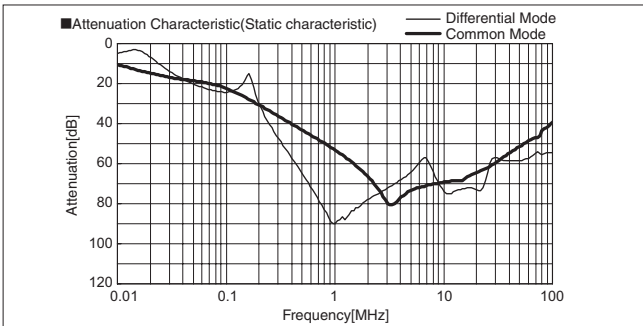

NBC-06-472

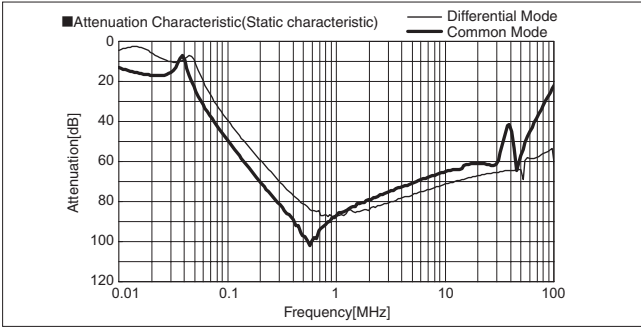

NBM-06-471

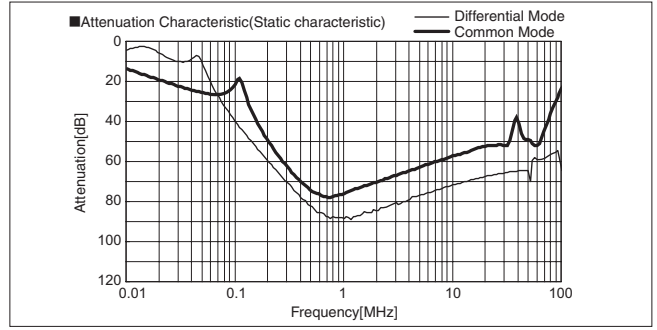

NBC-10-472

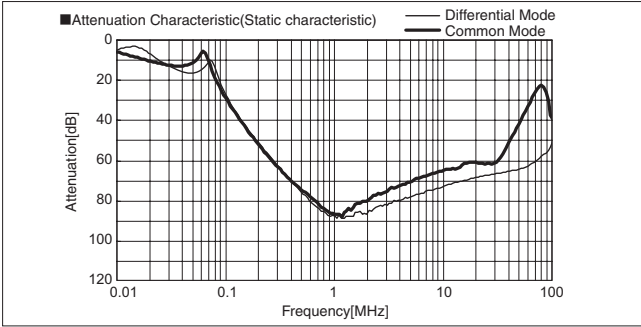

NBM-10-471

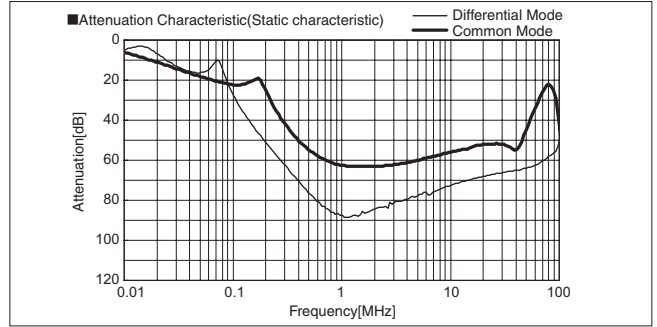

NBC-16-472

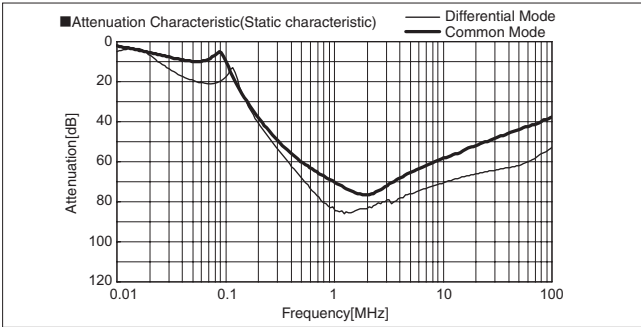

NBM-16-471

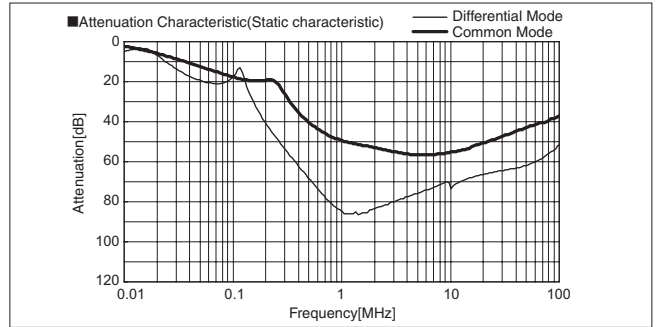

NBC-20-472

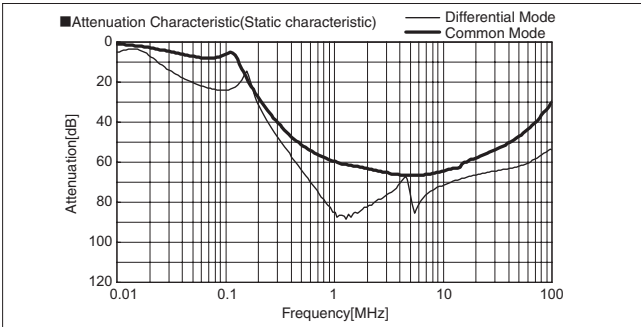

NBM-20-471

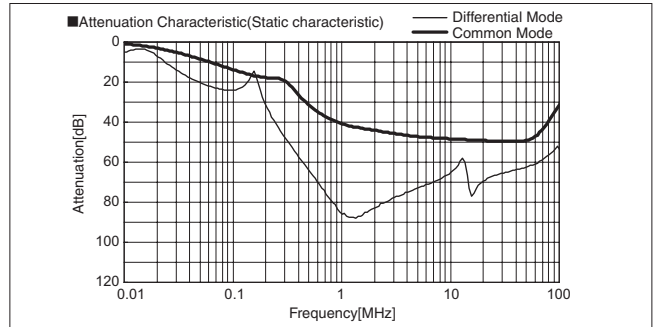

NBC-30-472

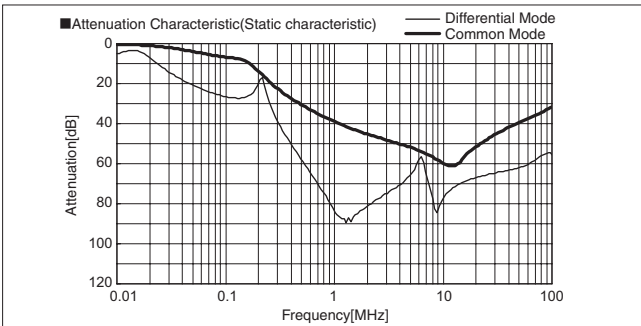

NBM-30-471

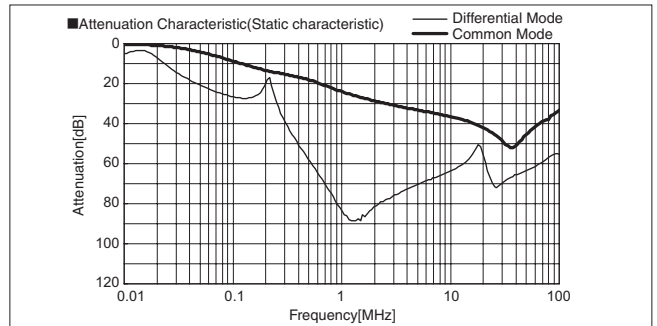

JAC series(6-30A)

JAC -30 -683 -□

① ② ③ ④

- ① Model Name
- ② Rated Current
- ③ Line to ground capacitor code: See table 1.1.

table 1.1 Line to ground capacitor code

Code	Leakage Current (Input 250/500V 60Hz) (Only "224" is 250/400V 60Hz)	Line to ground capacitor (nominal value)
103	0.5mA / 1.0mA max	10,000pF
223	1.0mA / 2.0mA max	22,000pF
683	2.5mA / 5.0mA max	68,000pF
224	15mA / 24mA max	220,000pF

* When the line to ground capacitor code is different, the attenuation characteristic is different.

- ④ Option
- D: DIN rail installation type
* The dimensions change when the option is set. Refer to External view.
- H: Ultra high-attenuation type
"103", "223", "683" is applied.
- U: Improve differential mode attenuation (Rated voltage 250V)



RoHS

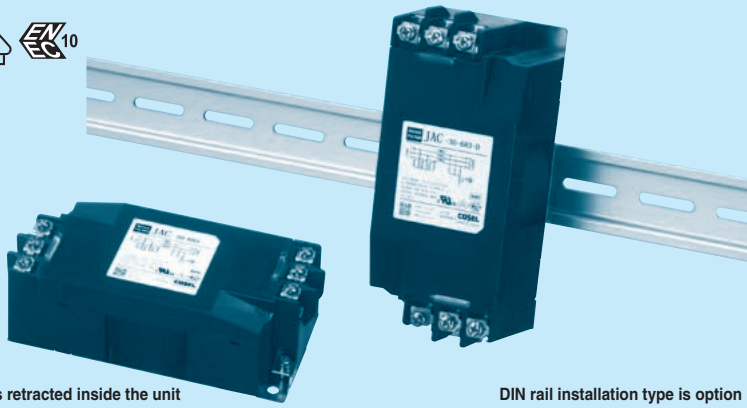

The terminal cover is retracted inside the unit

DIN rail installation type is option

Features of JAC series

Compact and low profile, common mode EMI/EMC filters in 150kHz to 1MHz (1-stage filter)

- Three Phase 500 VAC
- Push down type terminal block
- Selectable leakage current value, Ultra high-attenuation type "224" for EU (Y type with neutral earth system)

Specifications

No.	Items	JAC-06-683	JAC-10-683	JAC-20-683	JAC-30-683
1	Rated Voltage[V]	AC Three Phase 500 (voltage range: 528 max) 50/60Hz *1 *2			
2	Rated Current[A]	6	10	20	30
3	Test Voltage (Terminal-Mounting Plate)	2,500 VAC (Cutoff Current = 100mA), 1minute at room temperature and humidity *3			
4	Isolation Resistance (Terminal-Mounting Plate)	500 VDC 100MΩ min at room temperature and humidity *4			
5	Leakage current 250/500V 60Hz	2.5mA/5.0mA max			
6	DC resistance	100mΩ max	45mΩ max	15mΩ max	8mΩ max
7	Safety agency approval temperatures	-25 to +85°C (Refer to Derating Curve)			
8	Operating temperature	-40 to +85°C (Refer to Derating Curve)			
9	Operating humidity	20 to 95%RH (Non condensing)			
10	Storage temperature/humidity	-40 to +85°C/20 to 95%RH (Non condensing)			
11	Vibration	10 to 55Hz, 19.6m/s ² (2G), 3min. Period, 1hour each X, Y and Z axis			
12	Impact	196.1m/s ² (20G), 11ms Once each X, Y and Z axis			
13	Safety agency approvals	UL1283, CSA C22.2 No.8 (C-UL), DIN EN60939 VDE0565 Teil3-1, ENEC			
14	Case size (without projection)	63 X 44 X 132 mm (W X H X D) (Option: -D refer to external view) [2.48 X 1.73 X 5.20 inches] (W X H X D)			
15	Weight	440g max			

- *1 Capacitor code "224" : Three Phase Δ-connection 400 (440 max), Y-connection 500 (528 max).
- *2 "JAC-□□□□□□□□□□-U" : Three Phase 250 (275 max).
- *3 Capacitor code "224" : 2,800VDC (Cutoff Current = 10mA), 1 minute at room temperature and humidity.
- *4 Capacitor code "224" : Isolation resistance specification is deleted.

Circuit Diagram

(1) Line to ground capacitor code : 103, 223, 683

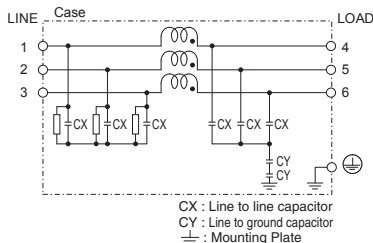

(2) Line to ground capacitor code : 224

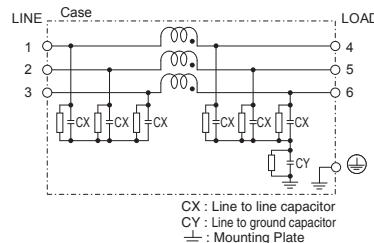

(3) Line to ground capacitor code : 103, 223, 683
Option : U

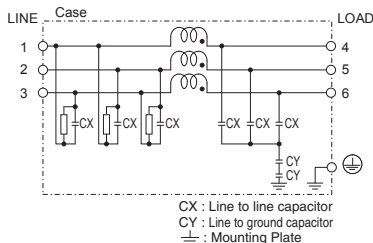

(4) Line to ground capacitor code : 224
Option : U

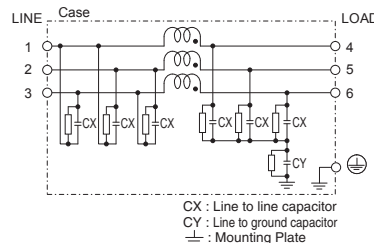

Derating Curve

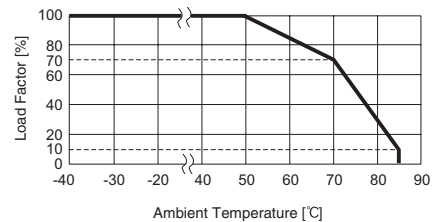

External view

This product is shipped in the following condition, because it is equipped with push-down terminals.

- ① The terminal cover is retracted inside the unit.
- ② The screws for connecting the terminals are held in the up right position.

Standard Type

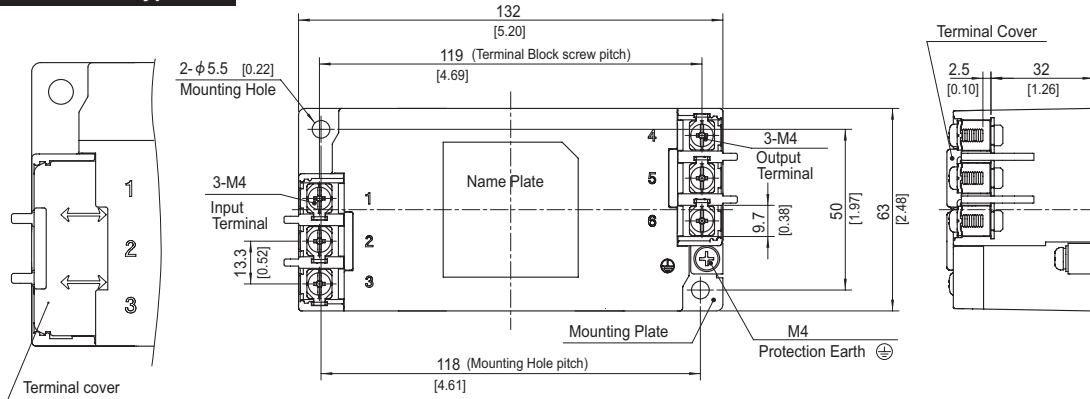

※ Close the terminal cover

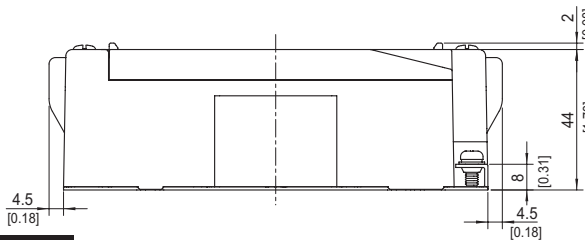

- ※ Tolerance : $\pm 1[\pm 0.04]$
- ※ Weight : 440g max
- ※ Mounting Plate : Iron(surface finishing : nickel plating) $t=1.0[0.04]$
- ※ Case : PBT
- ※ Dimensions in mm, []=inches
- ※ Terminal block screw tightening torque M4 : 1.6N · m(16.9kgf · cm)max

DIN rail installation Type

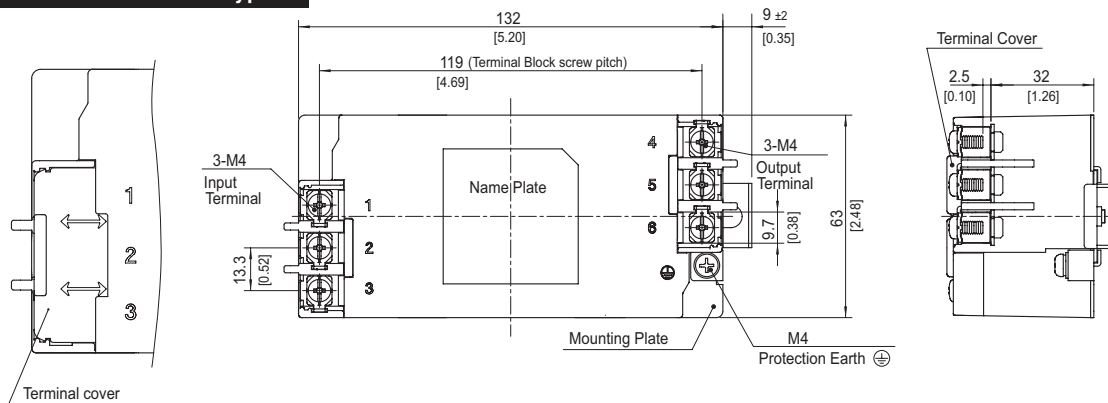

※ Close the terminal cover

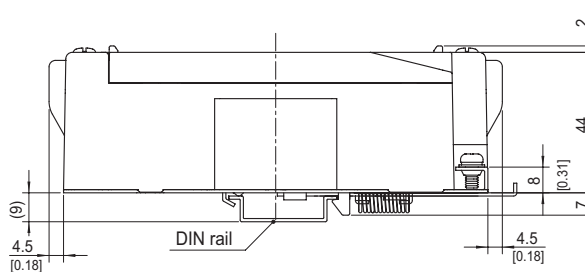

- ※ Tolerance : $\pm 1[\pm 0.04]$
- ※ Weight : 440g max
- ※ Mounting Plate : Iron(surface finishing : nickel plating) $t=1.0[0.04]$
- ※ Case : PBT
- ※ Dimensions in mm, []=inches
- ※ Terminal block screw tightening torque M4 : 1.6N · m(16.9kgf · cm)max

■ Note when installing the EMI/ EMC Filter on a DIN rail.

When the EMI/EMC Filter is grounded through the DIN rail, the proper noise attenuation may not be achieved.

Be sure to connect the protection earth (PE) of the EMI/EMC Filter body to the earth.

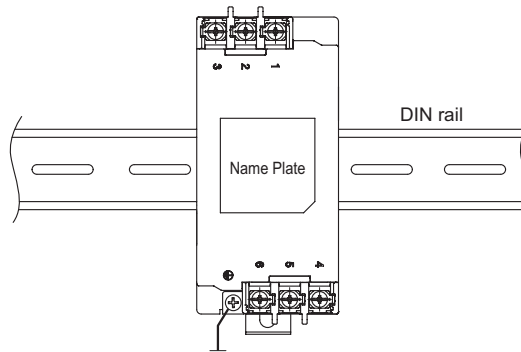

JAC-06-103-H

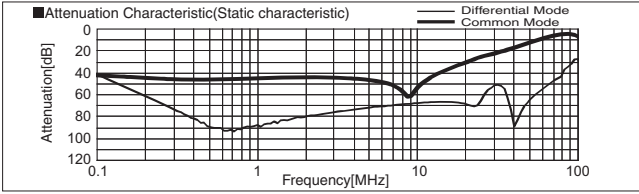

JAC-06-223-H

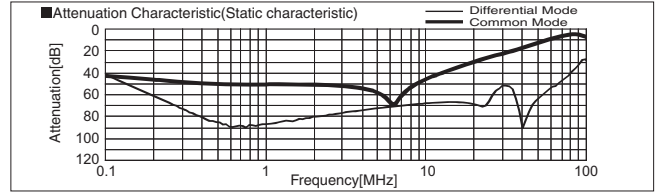

JAC-06-683-H

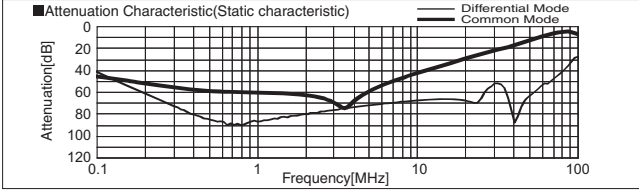

JAC-10-103-H

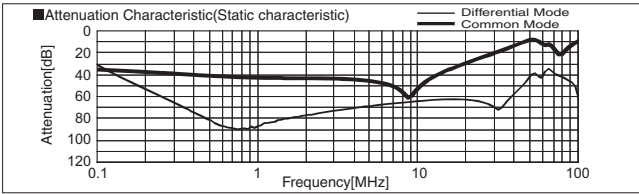

JAC-10-223-H

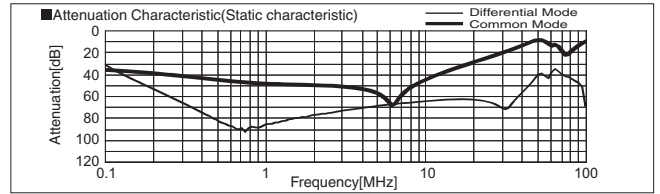

JAC-10-683-H

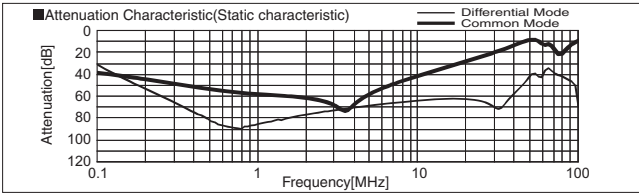

JAC-20-103-H

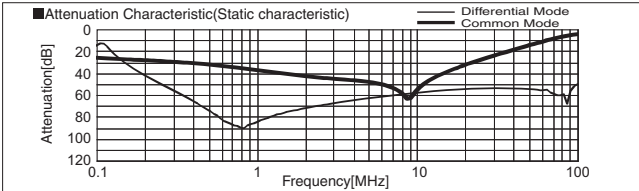

JAC-20-223-H

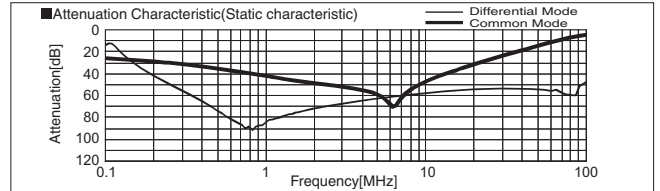

JAC-20-683-H

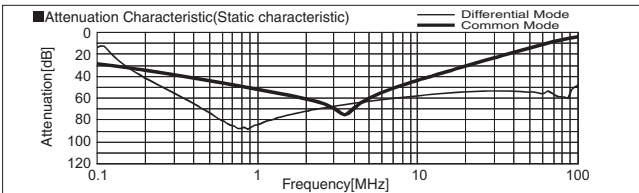

JAC-30-103-H

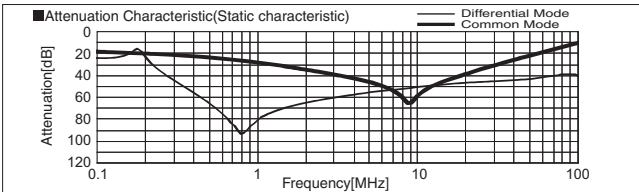

JAC-30-223-H

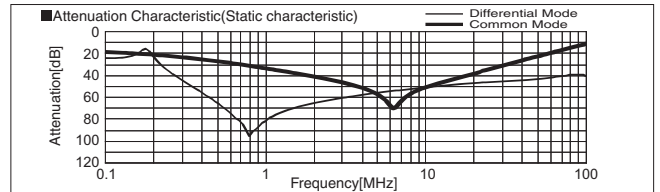

JAC-30-683-H

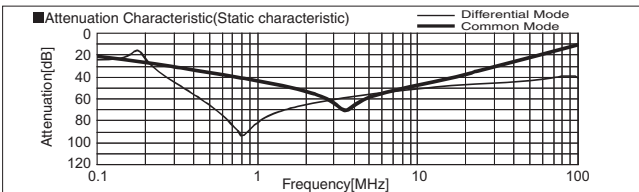

JAC series(40,50,60A)

JAC -50 -683 -□

① ② ③ ④



- ① Series Name
- ② Rated Current
- ③ Line to ground capacitor code: See table 1.1.

table 1.1 Line to ground capacitor code

Code	Leakage Current *1	Line to ground capacitor (nominal value)
	Upper row : Δ-connection Lower row : Y-connection	
103	0.5mA / 1.0mA max 0.05mA / 0.1mA max	0.01μF
223	1.0mA / 2.0mA max 0.1mA / 0.2mA max	0.022μF
683	2.5mA / 5.0mA max 0.35mA / 0.7mA max	0.068μF
224	15mA / 24mA max 2.0mA / 4.0mA max	0.22μF
155	80mA / 125mA max 9.0mA / 18mA max	1.5μF

* When the line to ground capacitor code is different, the attenuation characteristic is different.

*1 Input 250/500V 60Hz
(Δ-connection of "224", "155" is 250/400V 60Hz)

- ④ Option
- H: Ultra high-attenuation type
"103", "223", "683" is applied.
- U: Improve differential mode attenuation
(Rated voltage 250V)

Features of JAC series

Compact and low profile, common mode EMI/EMC filters in 150kHz to 1MHz (1-stage filter)

- Three phase rated voltage 500 VAC (voltage range : 528V max)
- Selectable leakage current value, Ultra high-attenuation type "224", "155" for EU (Y type with neutral earth system)

Specifications

No.	Items	JAC-40-683	JAC-50-683	JAC-60-683
1	Rated Voltage[V]	AC Three Phase 500 (voltage range: 528 max) 50/60Hz *2 *3		
2	Rated Current[A]	40	50	60
3	Test Voltage (Terminal-Mounting Plate)	2,500 VAC (Cutoff Current = 100mA), 1minute at room temperature and humidity *4		
4	Isolation Resistance (Terminal-Mounting Plate)	500 VDC 100MΩ min at room temperature and humidity *5		
5	Leakage current 250/500V 60Hz	2.5mA/5.0mA max		
6	DC resistance	7.0mΩ max	5.0mΩ max	3.5mΩ max
7	Safety agency approval temperatures	-40 to +85°C (Refer to Derating Curve)		
8	Operating temperature	-40 to +85°C (Refer to Derating Curve)		
9	Operating humidity	20 to 95%RH (Non condensing)		
10	Storage temperature/humidity	-40 to +85°C/20 to 95%RH (Non condensing)		
11	Vibration	10 to 55Hz, 19.6m/s ² (2G), 3min. Period, 1hour each X, Y and Z axis		
12	Impact	196.1m/s ² (20G), 11ms Once each X, Y and Z axis		
13	Safety agency approvals	UL60939[Overvoltage Category : III Altitude : 3000m], CSA C22.2 No.8 (C-UL) EN60939[DEMKO][Overvoltage Category: III Altitude: 3000m] , ENEC		
14	Case size (without projection)	65 X 54 X 153 mm (W X H X D) [2.56 X 2.13 X 6.02 inches] (W X H X D)		
15	Weight	800g max		

*2 Capacitor code "224" and "155" : Three Phase Δ-connection 400 (440 max), Y-connection 500 (528 max).

*3 "JAC-□□□□□□□□-U" : Three Phase 250 (275 max).

*4 Capacitor code "224" and "155" : 2,800VDC (Cutoff Current = 10mA), 1 minute at room temperature and humidity.

*5 Capacitor code "224" and "155" : Isolation resistance specification is deleted.

Circuit Diagram

(1) Line to ground capacitor code : 103, 223, 683

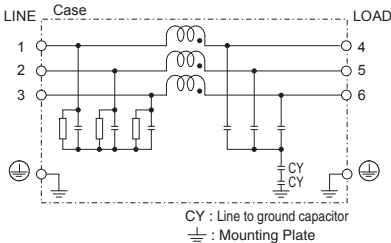

(2) Line to ground capacitor code : 224, 155

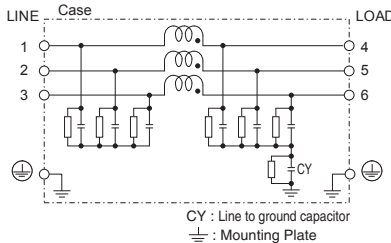

(3) Line to ground capacitor code : 103, 223, 683
Option : U

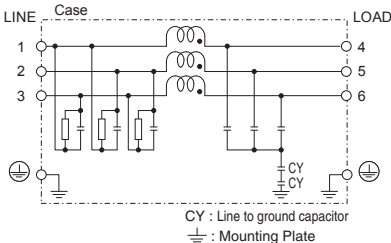

(4) Line to ground capacitor code : 224, 155
Option : U

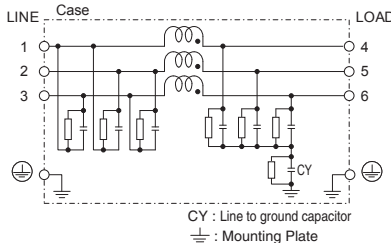

Derating Curve

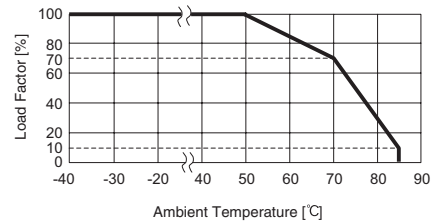

* Keep free ventilation holes for cooling.

External view

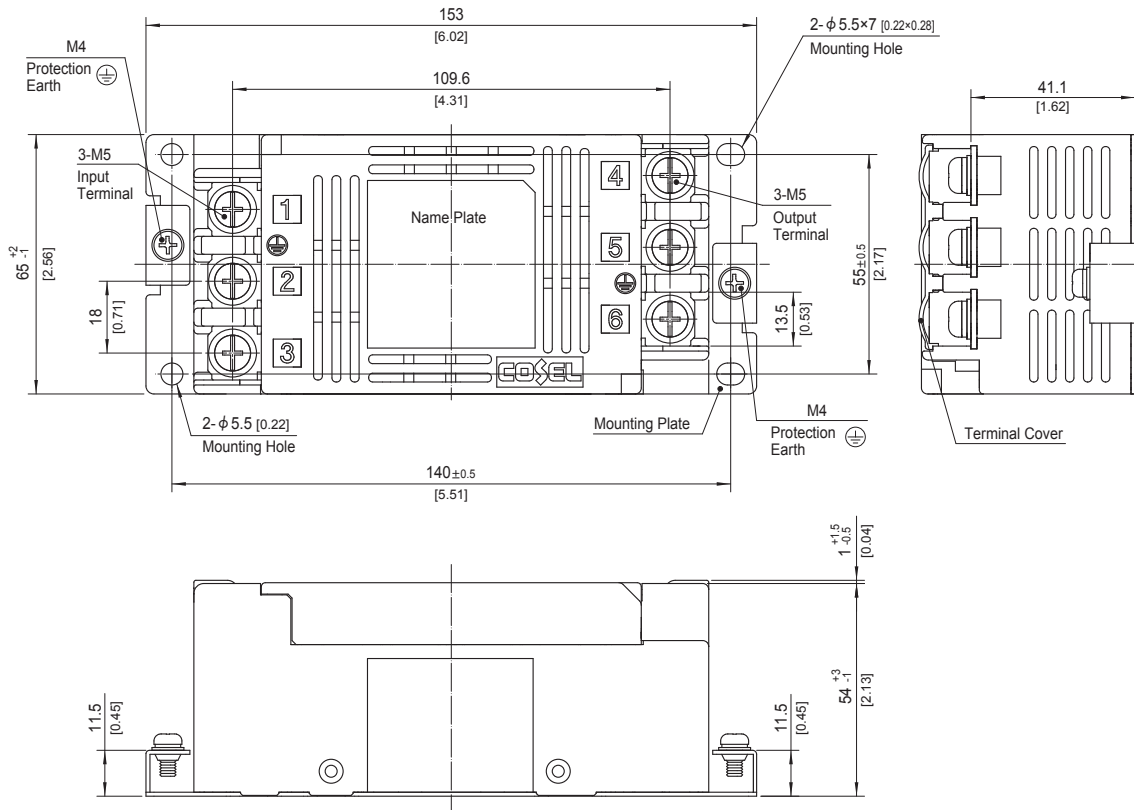

- ※ Tolerance : ± 1 [± 0.04]
- ※ Weight : 800g max
- ※ Mounting Plate : Hot-dip Galvanized Steel board $t=1.0$ [0.04]
- ※ Case Material : PBT
- ※ Dimensions in mm, []=inches
- ※ Terminal block screw tightening torque M5 : $3.0\text{N} \cdot \text{m}$ (30.7kgf · cm) max
- ※ Protection Earth (PE) screw tightening torque M4 : $1.6\text{N} \cdot \text{m}$ (16.9kgf · cm) max
- ※ Can not be mounted upside-down. (mounted the top surface)
- ※ Keep free ventilation holes for cooling.
- ※ Can be mounted using the 2 corner mounting holes.

JAC-40-103-H

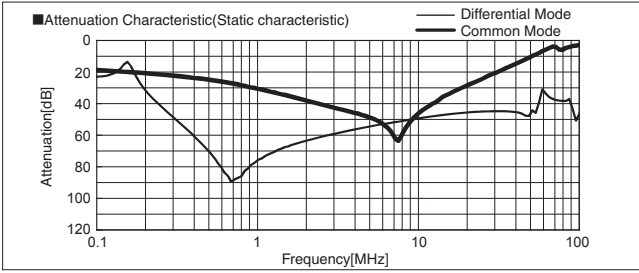

JAC-40-223-H

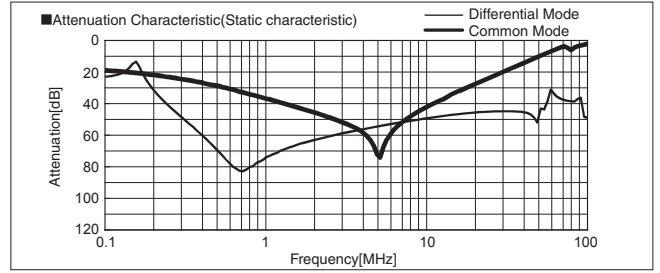

JAC-40-683-H

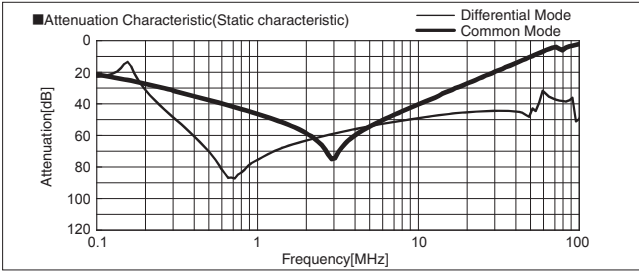

JAC-50-103-H

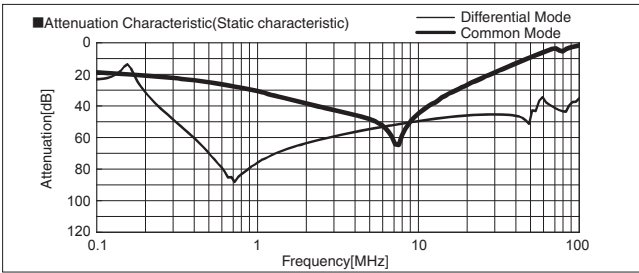

JAC-50-223-H

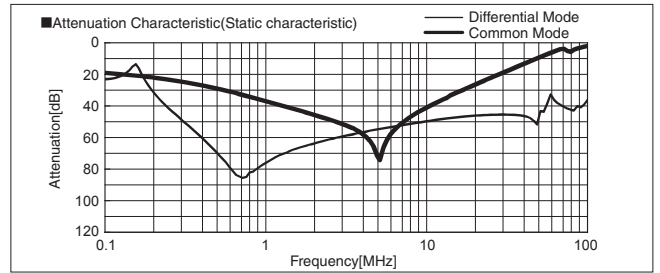

JAC-50-683-H

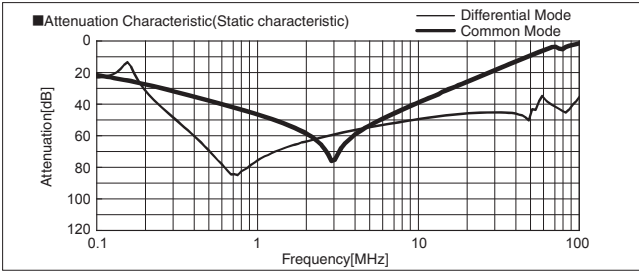

JAC-60-103-H

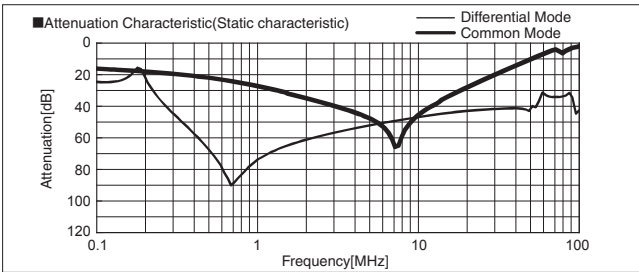

JAC-60-223-H

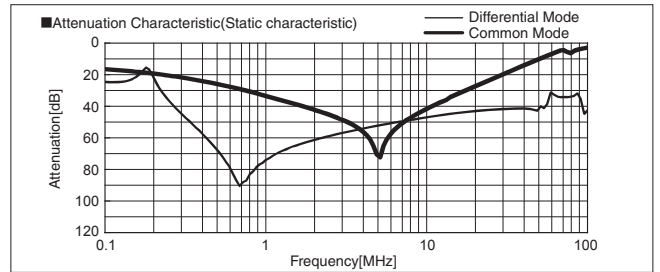

JAC-60-683-H

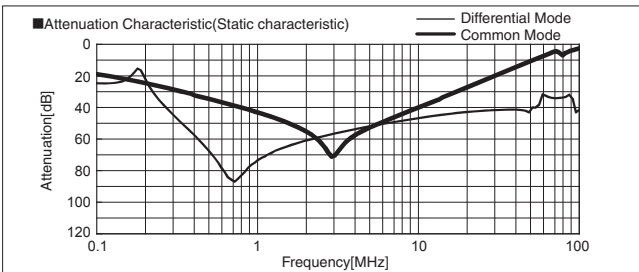

TAC/TAH series (4-30A)

TAC -10 -683 -□

① ② ③ ④

- ① Series Name
- ② Rated Current
- ③ Line to ground capacitor code: Refer to table 1.1.

table 1.1 Line to ground capacitor code

Code	Leakage Current (Input 250/500V 60Hz)	Line to ground capacitor (nominal value)
103	0.5mA/1.0mA max	10,000pF
223	1.0mA/2.0mA max	22,000pF
683	2.5mA/5.0mA max	68,000pF

* When the line to ground capacitor code is different, the attenuation characteristic is different.

- ④ Option
- D: DIN rail installation type

* The dimensions change when the option is set. Refer to External view.

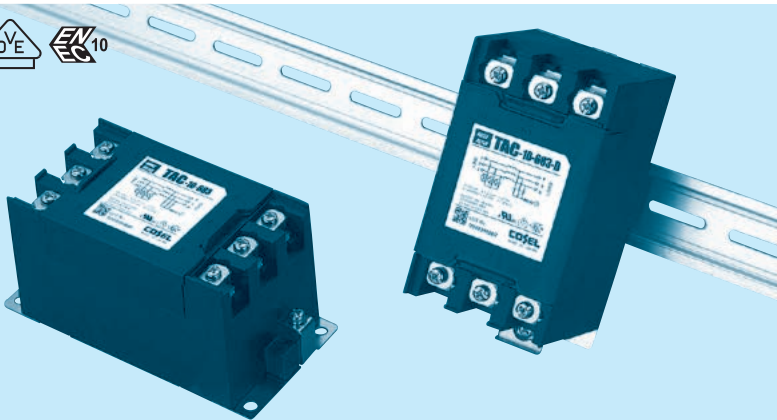

The terminal cover is retracted inside the unit

DIN rail installation type is option

Features of TAC/TAH series

- Three phase rated voltage 500VAC (voltage range:528V max) (1-Stage filter)
- Selectable leakage current value
- Quick and easy push-down terminal

Just connect the wires, push-down and tighten the screws with a screwdriver.

■ TAC: High-attenuation type from 150kHz to 1MHz

■ TAH: Ultra high-attenuation type from 9kHz to 1MHz

Specifications

No.	Items	TAC-04-683	TAC-06-683	TAC-10-683	TAC-20-683	TAC-30-683
		TAH-04-683	TAH-06-683	TAH-10-683	TAH-20-683	TAH-30-683
1	Rated Voltage[V]	AC Three Phase 500 (voltage range:528 max) 50/60Hz				
2	Rated Current[A]	4	6	10	20	30
3	Test Voltage (Terminal-Mounting Plate)	2,000 VAC (Cutoff Current = 100mA), 1minute at room temperature and humidity				
4	Isolation Resistance (Terminal-Mounting Plate)	500 VDC 100MΩ min at room temperature and humidity				
5	Leakage current	Refer to table 1.1				
6	Voltage drop	1.5V max		1.0V max		
7	Safety agency approval temperatures	-25 to +85°C (Refer to Derating Curve)				
8	Operating temperature	-40 to +85°C (Refer to Derating Curve)				
9	Operating humidity	20 to 95%RH (Non condensing)				
10	Storage temperature/humidity	-40 to +85°C/20 to 95%RH (Non condensing)				
11	Vibration	10 to 55Hz, 19.6m/s ² (2G), 3min. Period, 1hour each X, Y and Z axis				
12	Impact	196.1m/s ² (20G), 11ms Once each X, Y and Z axis				
13	Safety agency approvals	UL1283, CSA C22.2 No.8 (C-UL) , DIN EN60939 VDE0565 Teil3-1, ENEC				
14	Case size (without projection) /Weight	63×64×128 mm [2.48×2.52×5.04 inches] (W×H×D) / 620g max (Option : -D refer to external view)				

Circuit Diagram

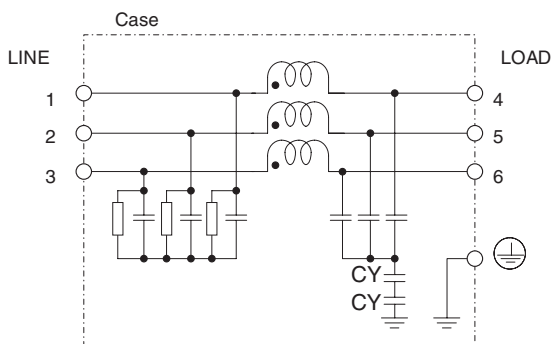

CY : Line to ground capacitor ⊥ : Mounting Plate

Derating Curve

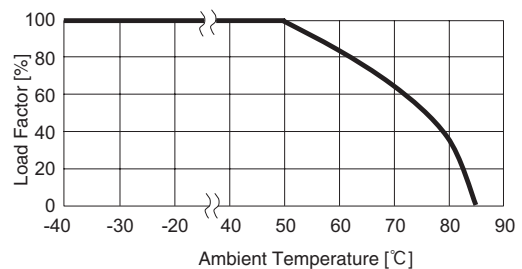

External view

This product is shipped in the following condition, because it is equipped with push-down terminals.

- ① The terminal cover is closed.
- ② The screws for connecting the terminals are held in the up right position.

Standard Type

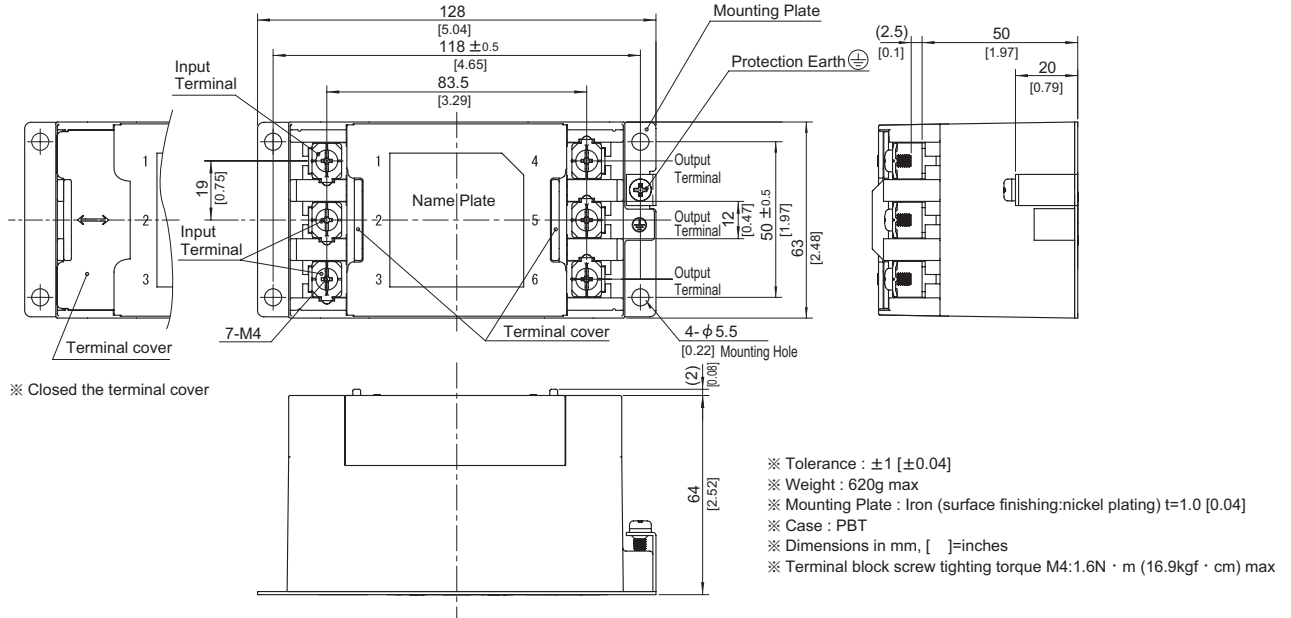

DIN rail installation Type

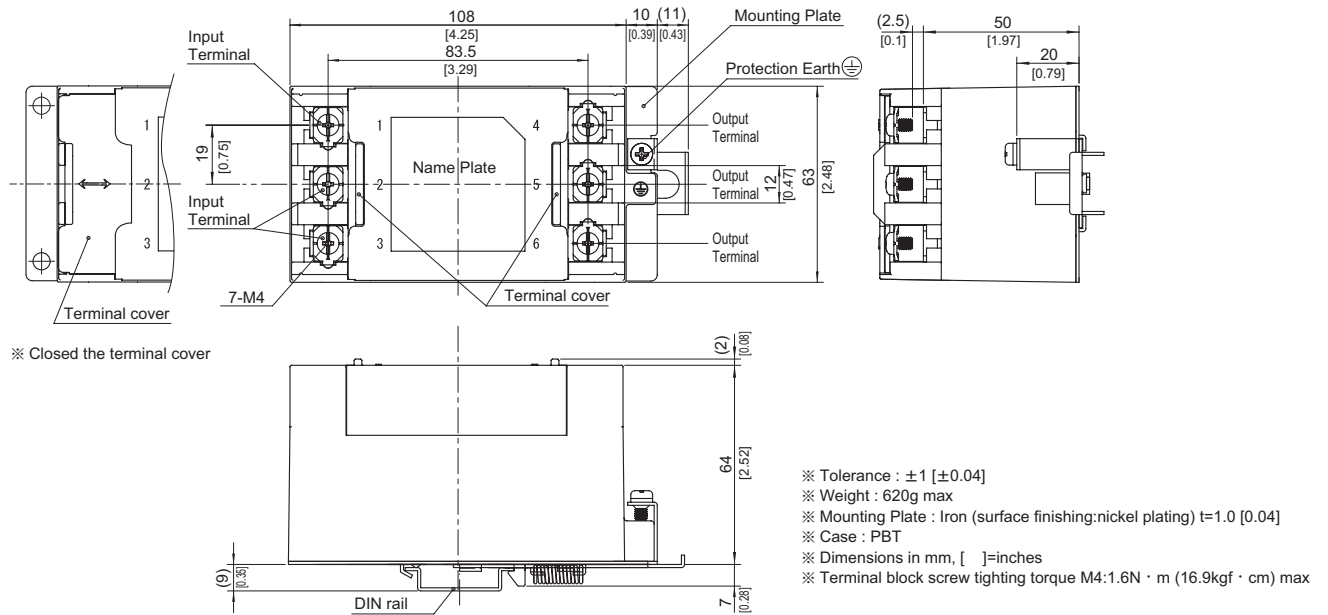

■Note when installing the EMI/EMC Filter on a DIN rail.

When the EMI/EMC Filter is grounded through the DIN rail, the proper noise attenuation may not be achieved.

Be sure to connect the protection earth (PE) of the EMI/EMC Filter body to the earth.

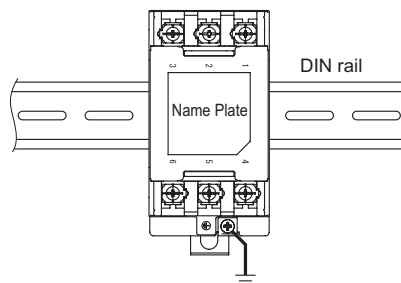

TAC-04-103

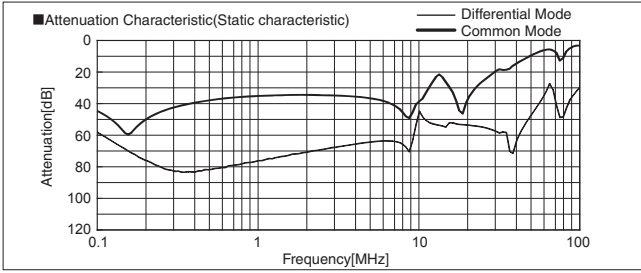

TAC-04-223

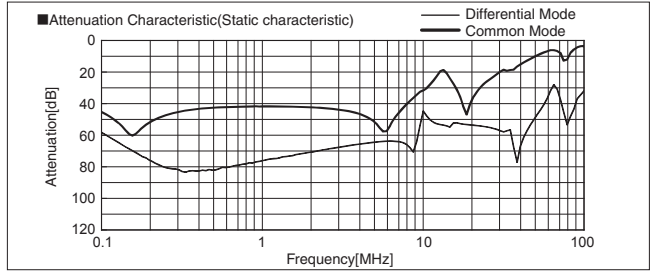

TAC-04-683

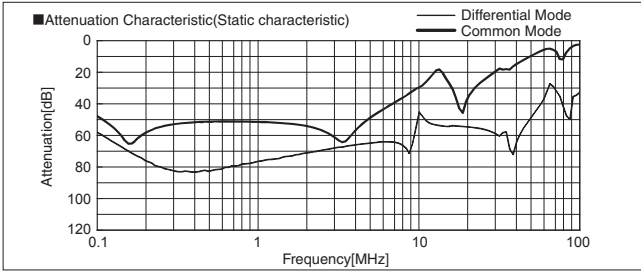

TAC-06-103

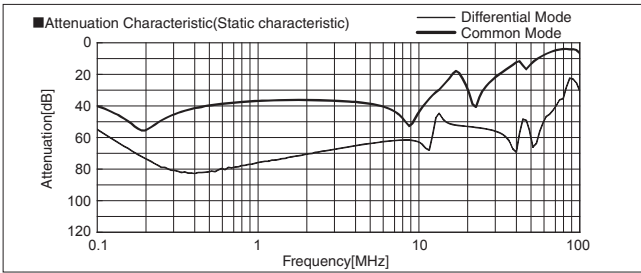

TAC-06-223

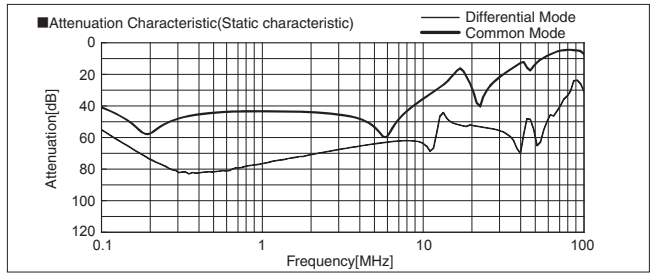

TAC-06-683

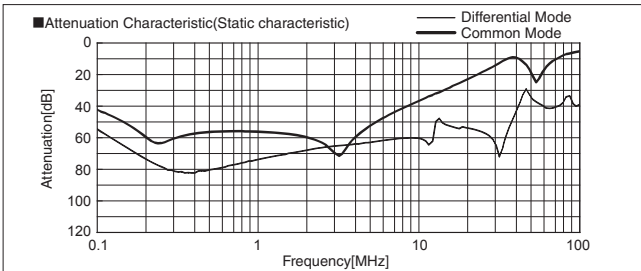

TAC-10-103

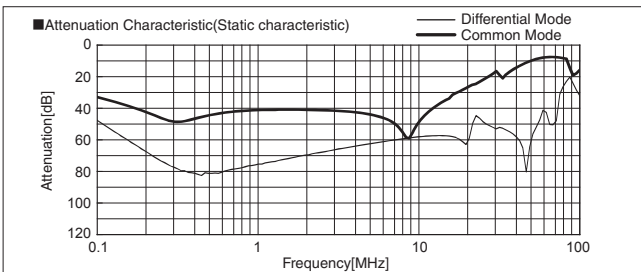

TAC-10-223

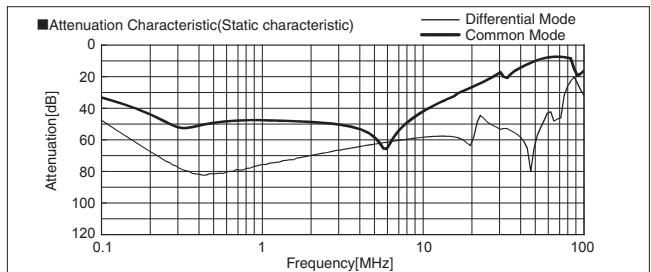

TAC-10-683

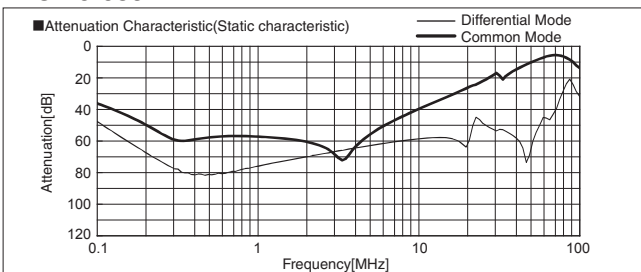

TAC-20-103

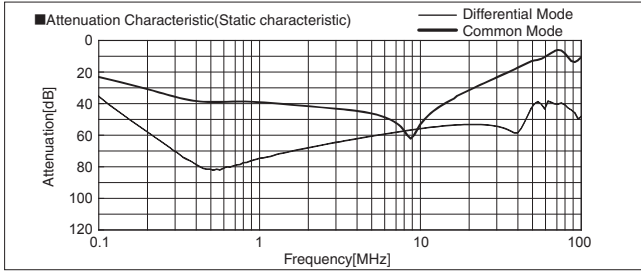

TAC-20-223

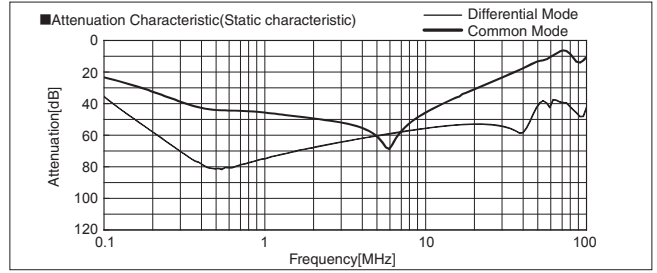

TAC-20-683

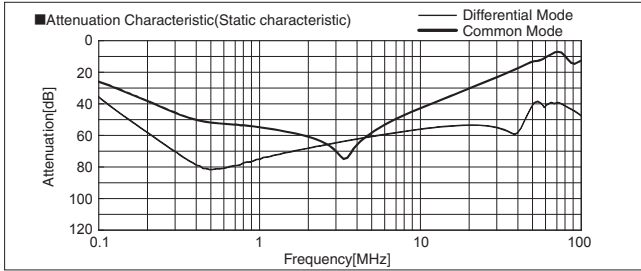

TAC-30-103

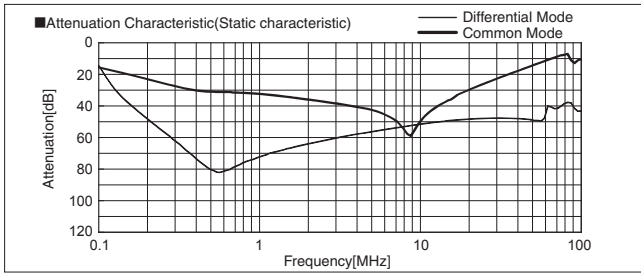

TAC-30-223

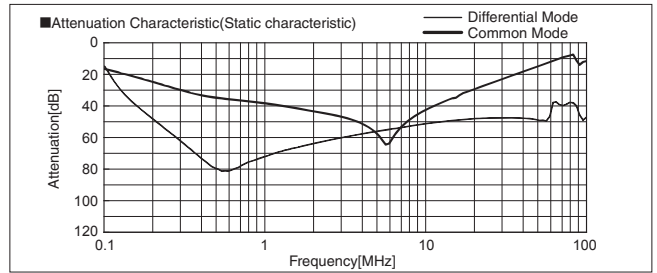

TAC-30-683

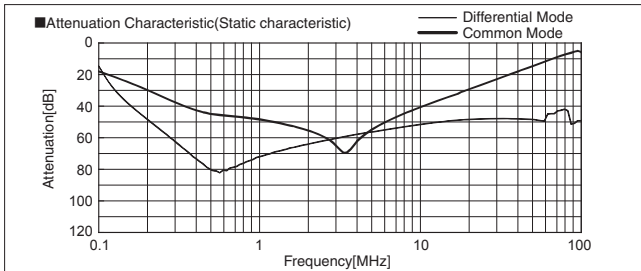

TAH-04-103

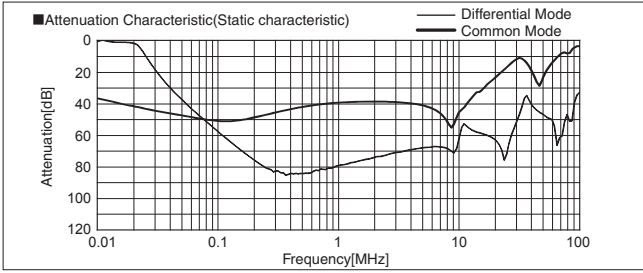

TAH-04-223

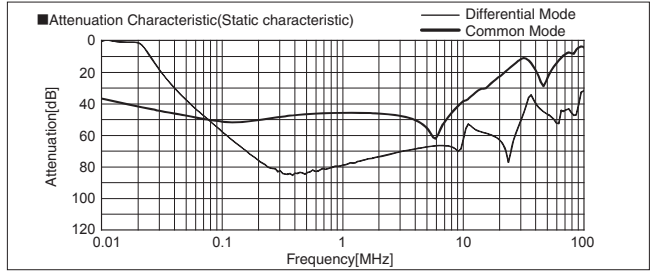

TAH-04-683

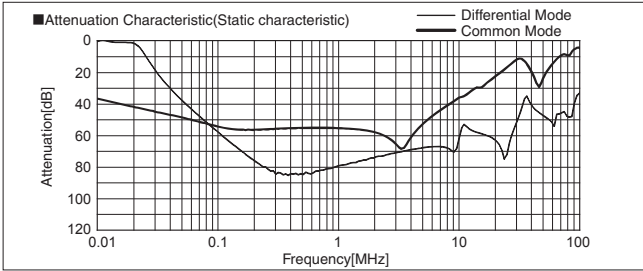

TAH-06-103

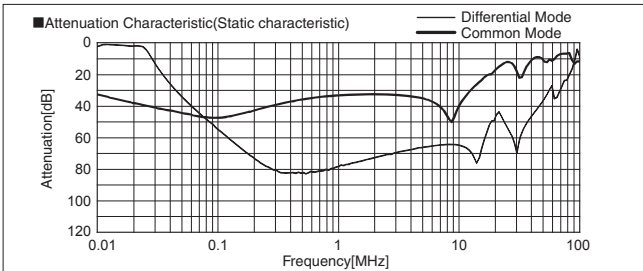

TAH-06-223

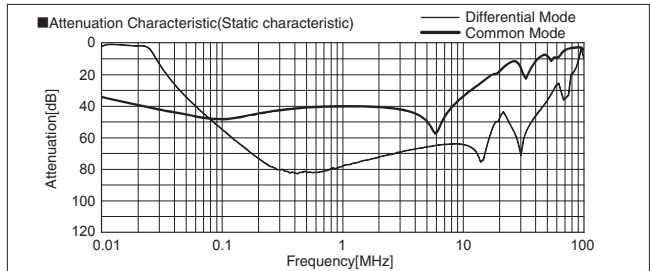

TAH-06-683

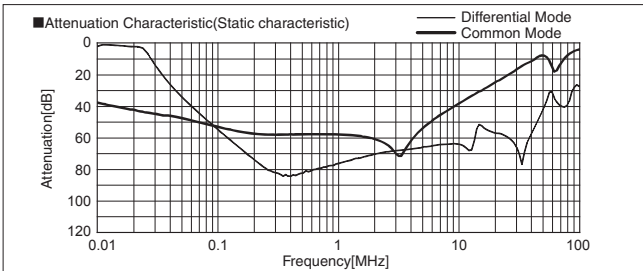

TAH-10-103

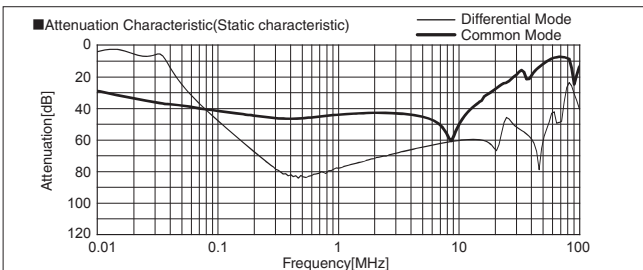

TAH-10-223

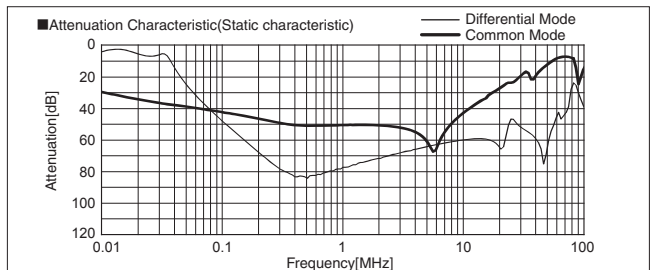

TAH-10-683

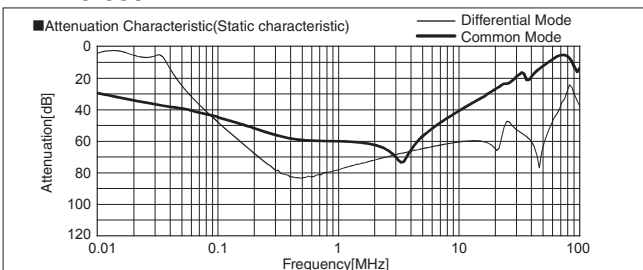

TAH-20-103

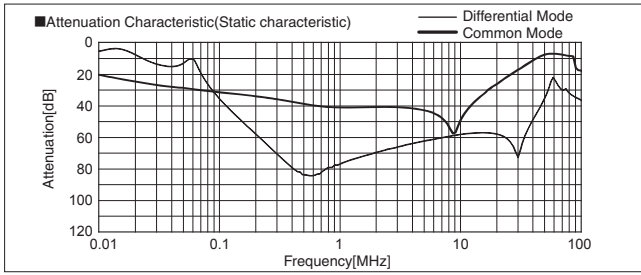

TAH-20-223

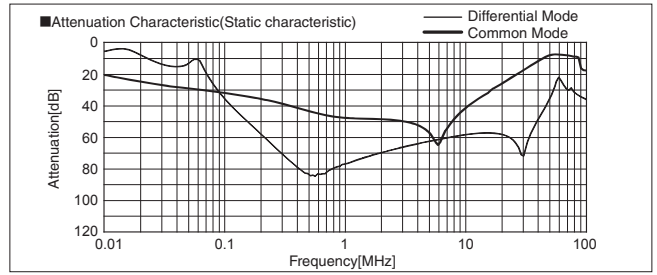

TAH-20-683

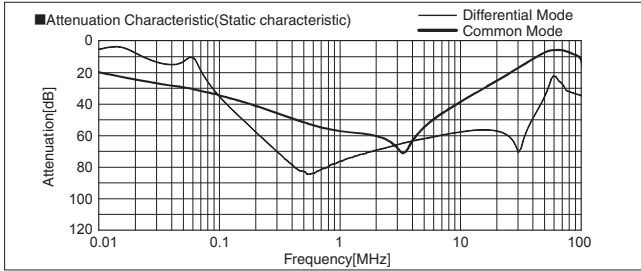

TAH-30-103

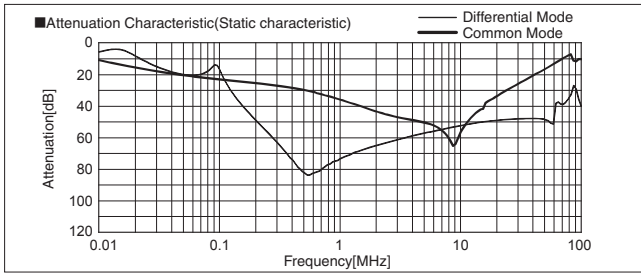

TAH-30-223

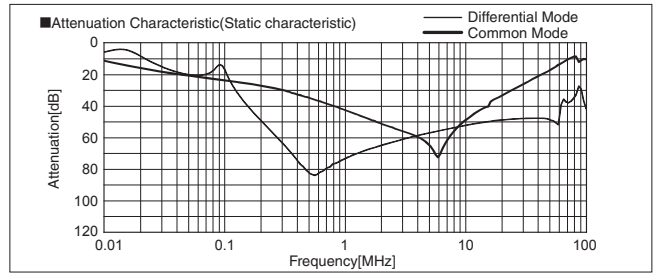

TAH-30-683

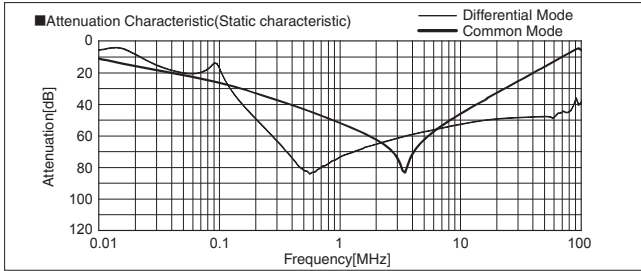

External view

TAC-50-□□□ / TAC-60-□□□
TAH-50-□□□ / TAH-60-□□□

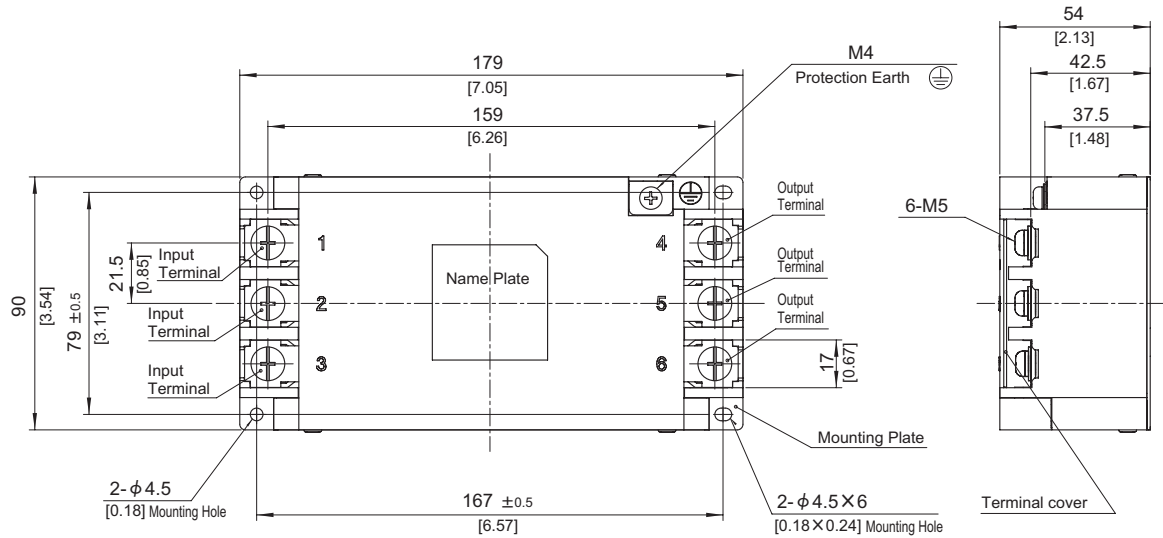

※ Can not be mounted upside-down.
(mounted the top surface)

※ Tolerance : ±1 [±0.04]
 ※ Weight : 1.4kg max
 ※ Mounting Plate : Iron (surface finishing:nickel plating) t=1.2 [0.05]
 ※ Case : PBT
 ※ Dimensions in mm, []=inches
 ※ Terminal block screw tightening torque M5:3.0N · m (30.7kgf · cm) max
 ※ Protection Earth screw tightening torque M4:1.6N · m (16.9kgf · cm) max

TAC-80-□□□ / TAC-100-□□□
TAH-80-□□□ / TAH-100-□□□

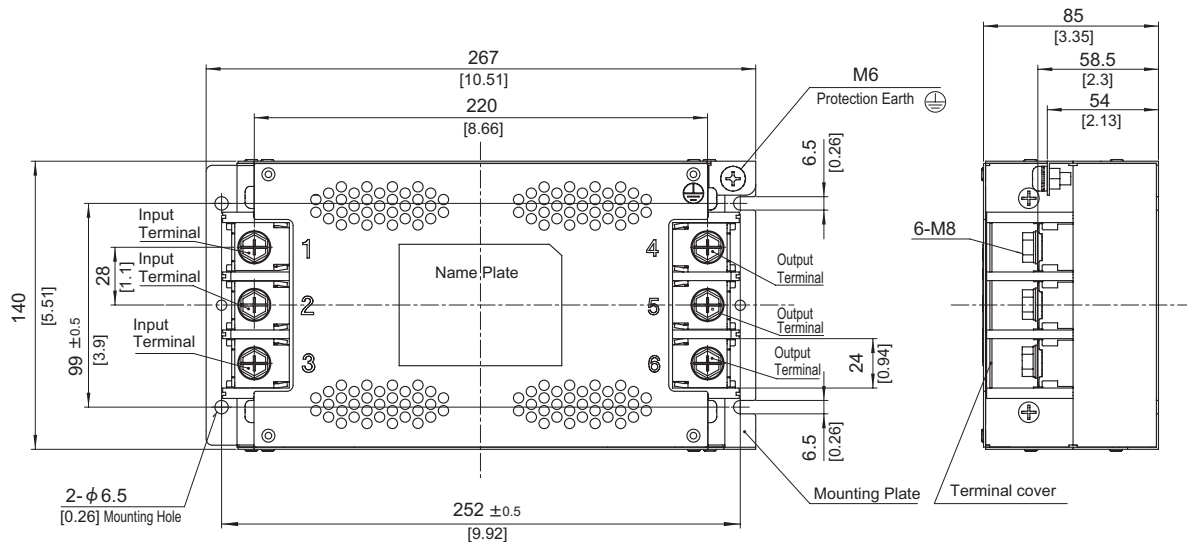

※ Can not be mounted upside-down.
(mounted the top surface)

※ Tolerance : ±1 [±0.04]
 ※ Weight : 3.8kg max
 ※ Chassis Material : Stainless steel t=1.0 [0.04]
 ※ Dimensions in mm, []=inches
 ※ Terminal block screw tightening torque M8:9.2N · m (93.9kgf · cm) max
 ※ Protection Earth screw tightening torque M6:5.8N · m (59.2kgf · cm) max

External view

TAC-150-□□□
TAH-150-□□□

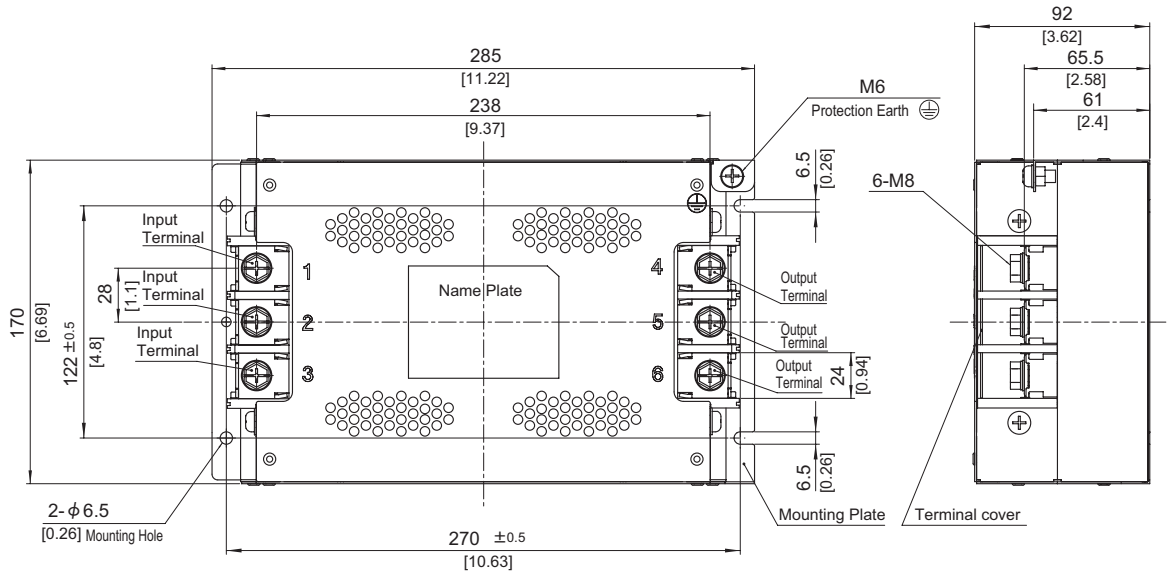

※ Can not be mounted upside-down.
(mounted the top surface)

- ※ Tolerance : ± 1 [± 0.04]
- ※ Weight : 4.8kg max
- ※ Chassis Material : Stainless steel $t=1.0$ [0.04]
- ※ Dimensions in mm, []=inches
- ※ Terminal block screw tightening torque M8:9.2N · m (93.9kgf · cm) max
- ※ Protection Earth screw tightening torque M6:5.8N · m (59.2kgf · cm) max

TAC-50-103

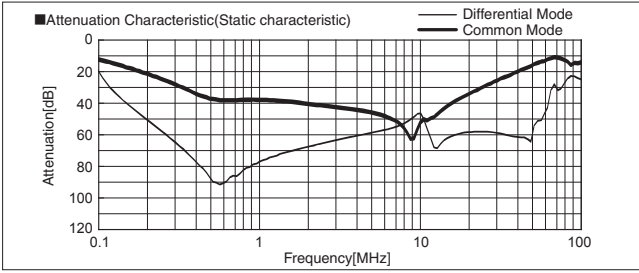

TAC-50-223

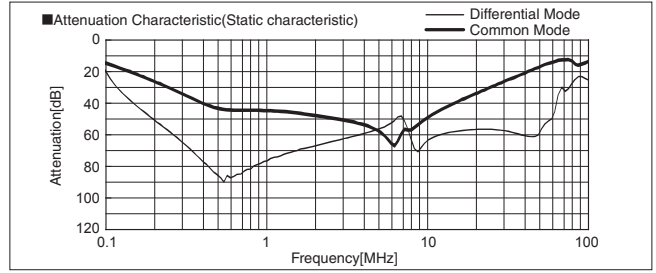

TAC-50-333

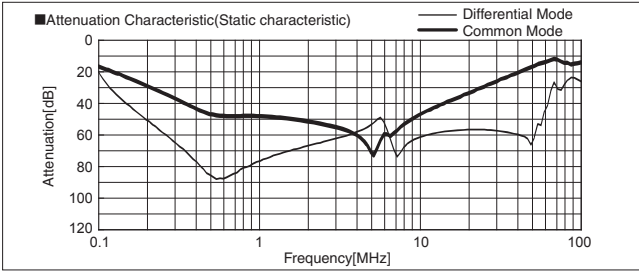

TAC-60-103

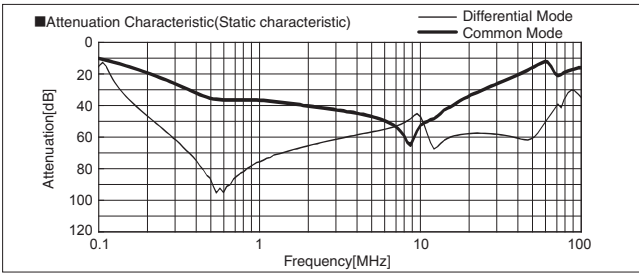

TAC-60-223

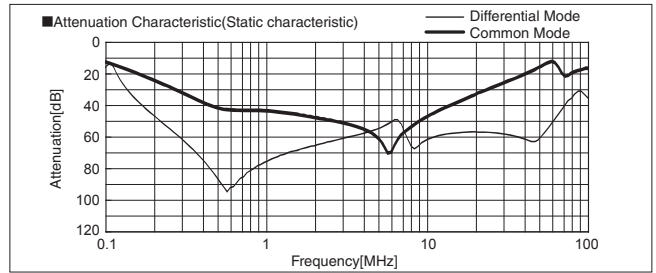

TAC-60-333

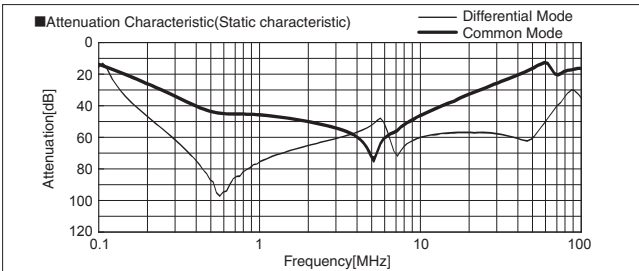

TAC-80-103

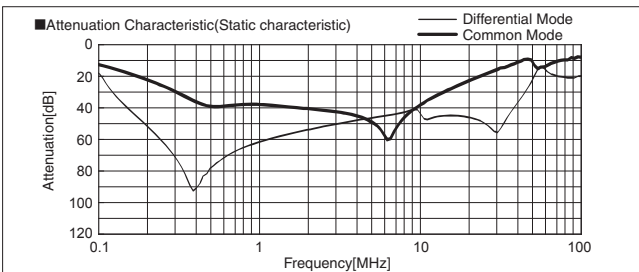

TAC-80-223

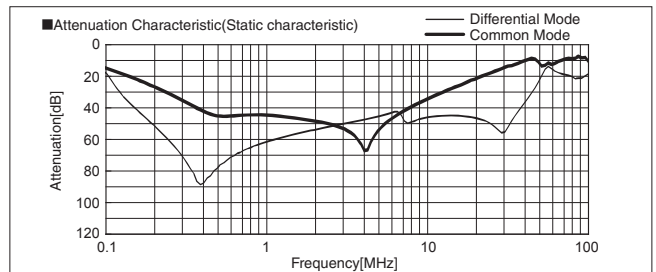

TAC-80-333

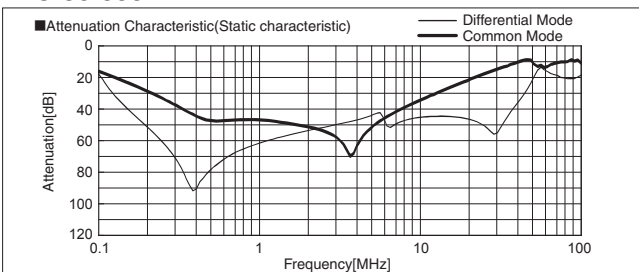

TAH-50-103

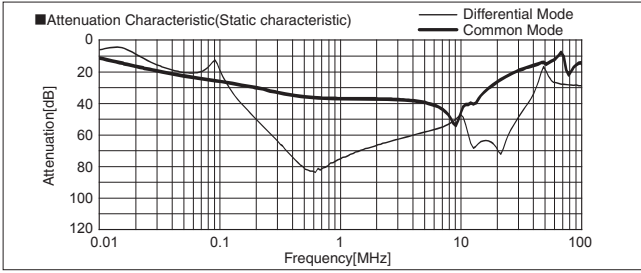

TAH-50-223

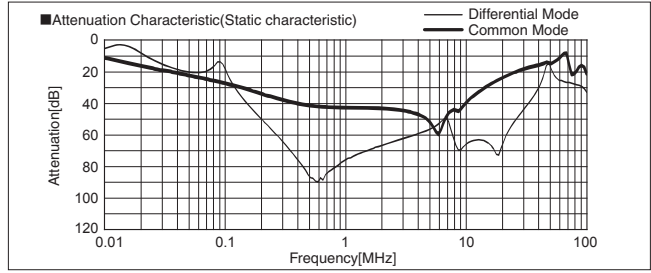

TAH-50-333

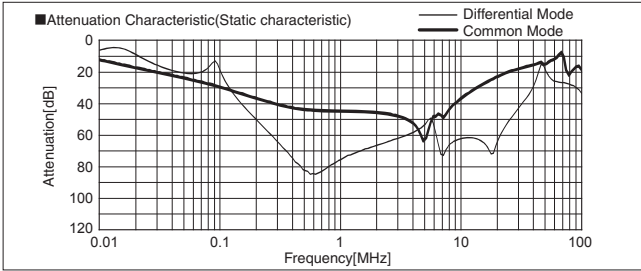

TAH-60-103

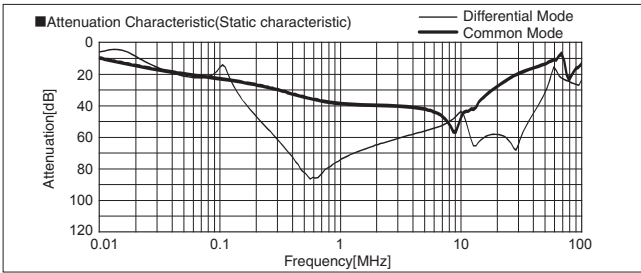

TAH-60-223

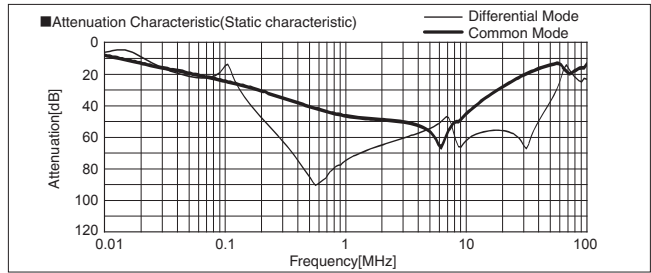

TAH-60-333

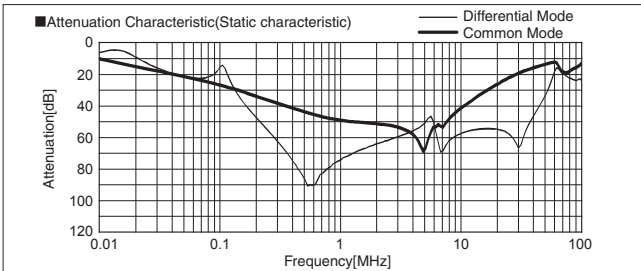

TAH-80-103

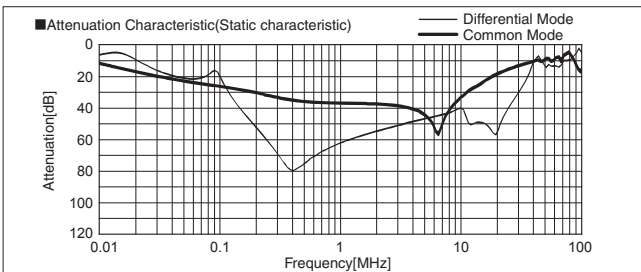

TAH-80-223

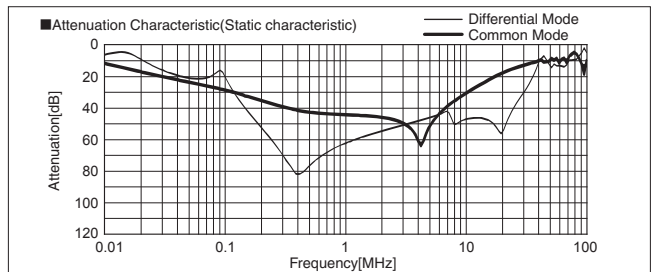

TAH-80-333

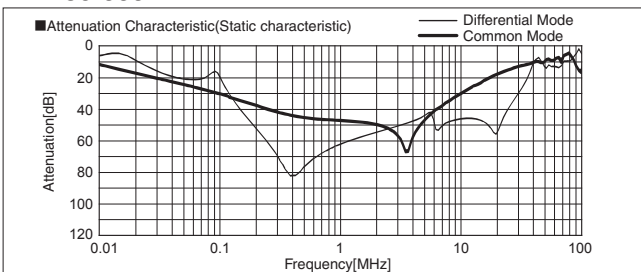

TAC-100-103

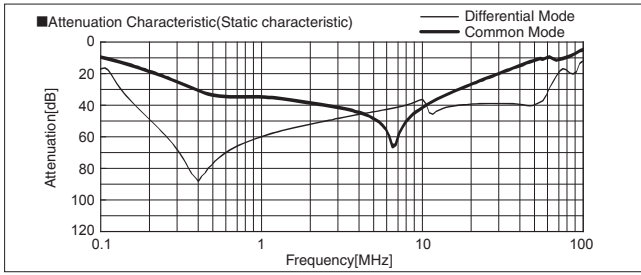

TAC-100-223

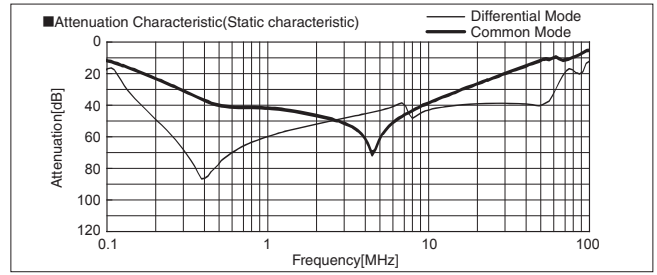

TAC-100-333

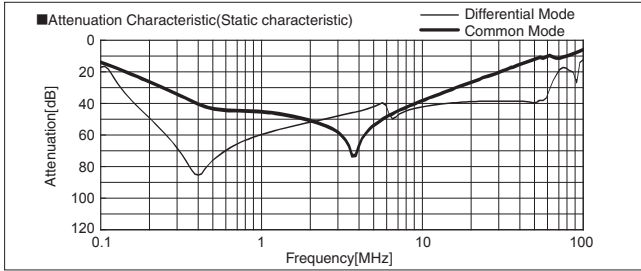

TAC-150-103

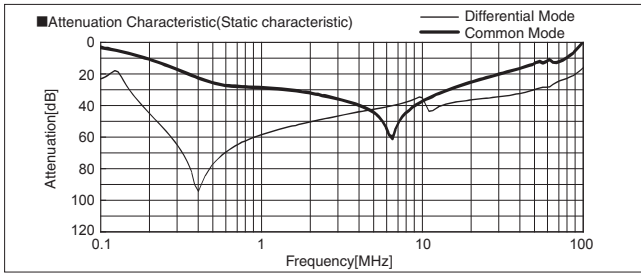

TAC-150-223

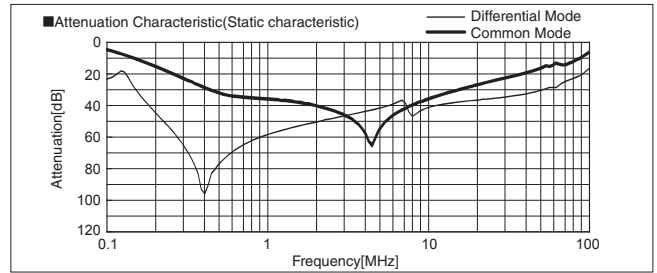

TAC-150-333

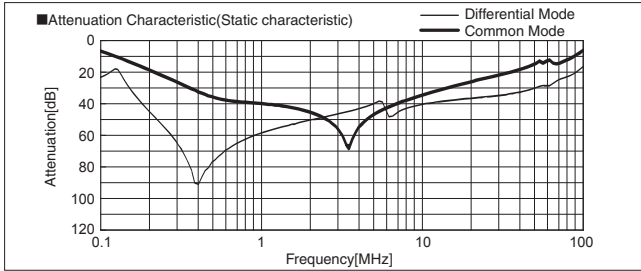

TAH-100-103

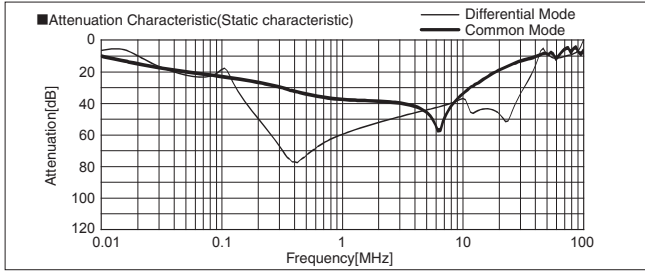

TAH-100-223

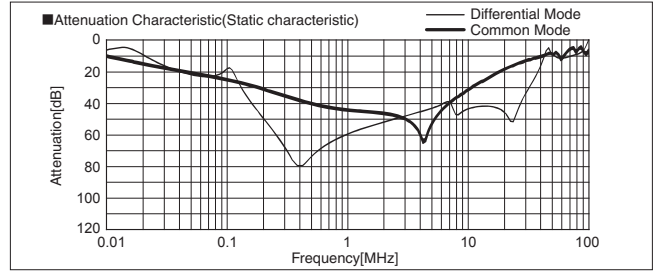

TAH-100-333

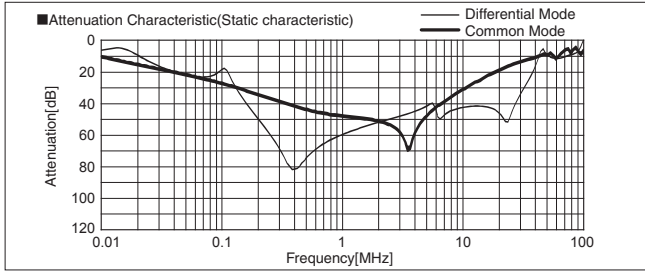

TAH-150-103

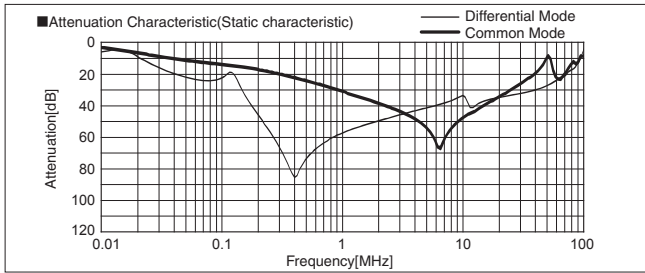

TAH-150-223

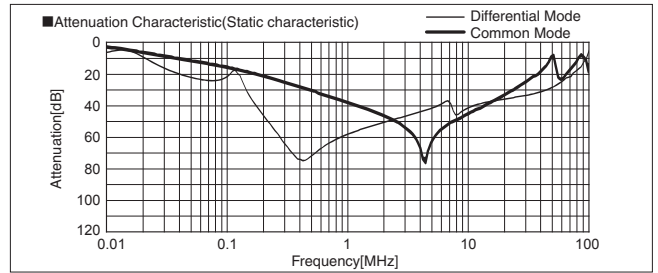

TAH-150-333

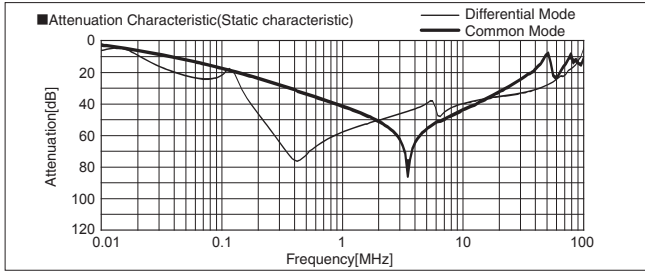

TAC-50-103-U

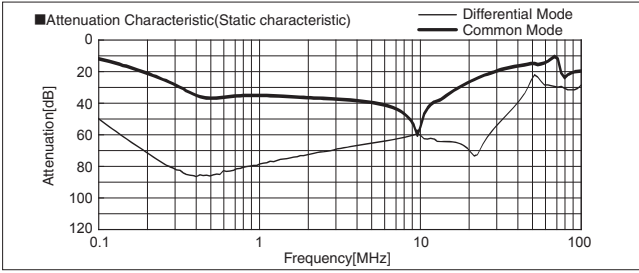

TAC-50-223-U

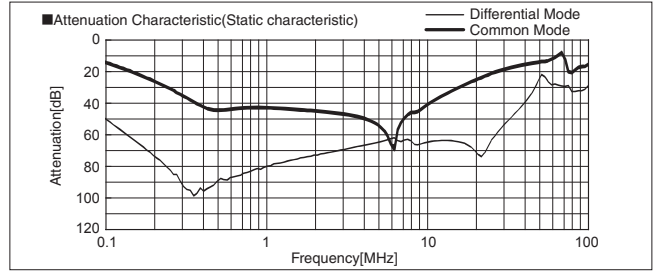

TAC-50-333-U

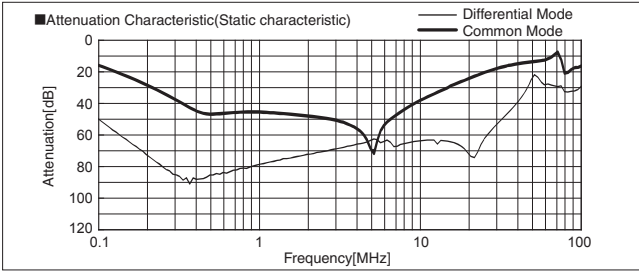

TAC-60-103-U

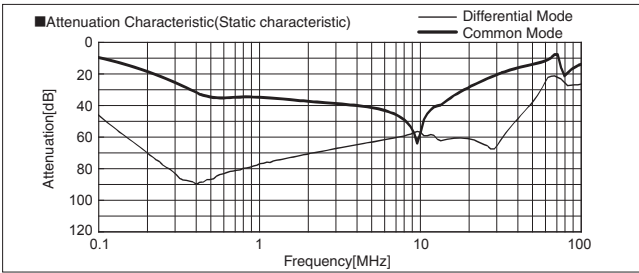

TAC-60-223-U

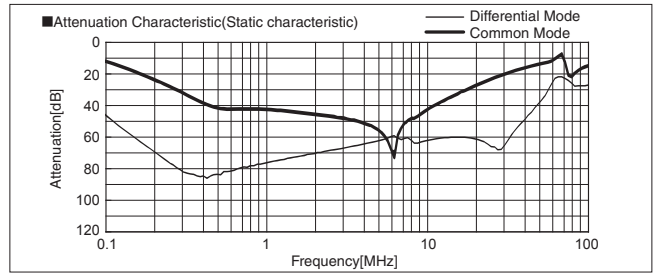

TAC-60-333-U

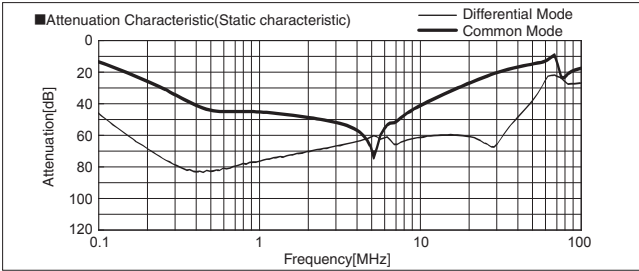

TAC-80-103-U

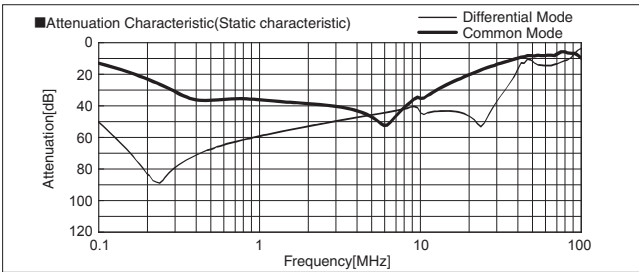

TAC-80-223-U

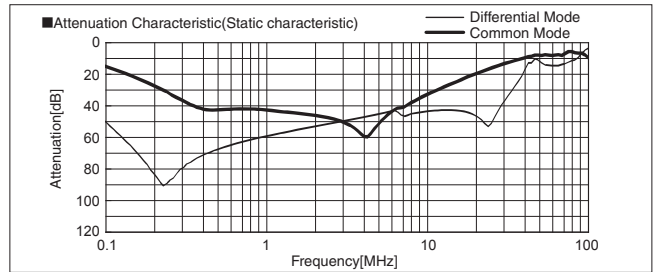

TAC-80-333-U

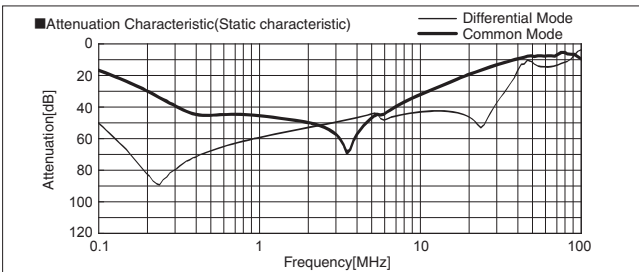

TAH-50-103-U

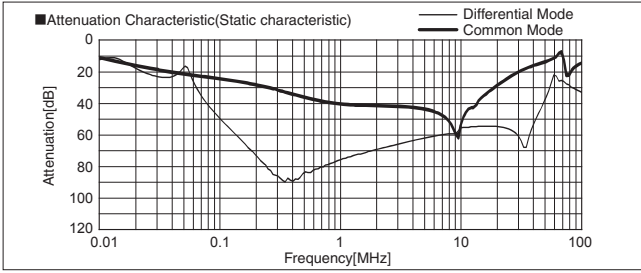

TAH-50-223-U

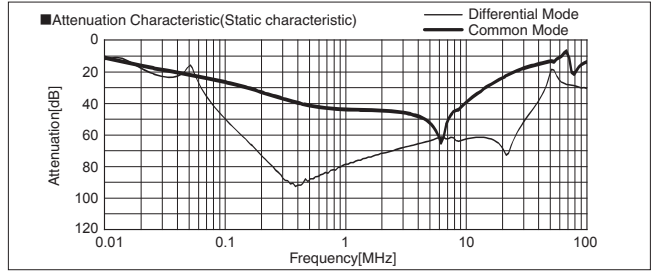

TAH-50-333-U

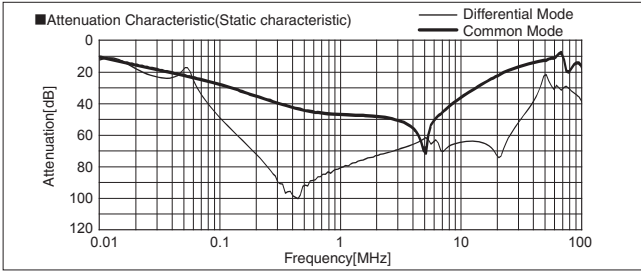

TAH-60-103-U

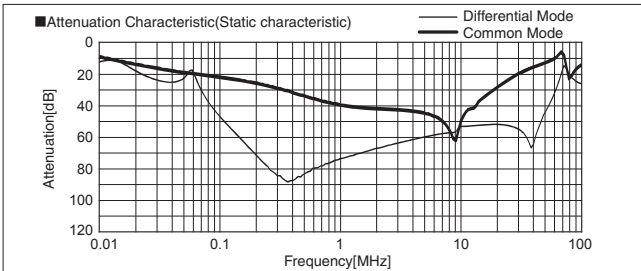

TAH-60-223-U

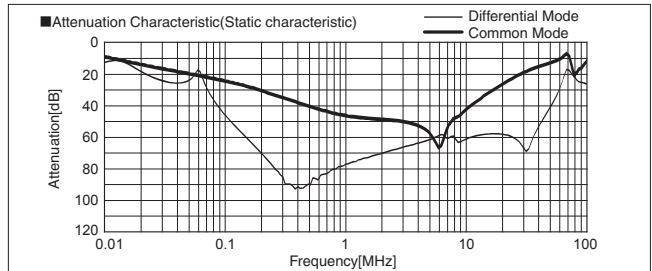

TAH-60-333-U

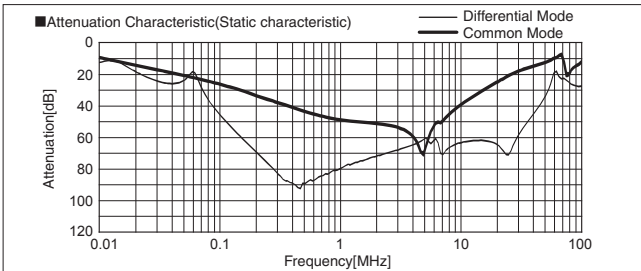

TAH-80-103-U

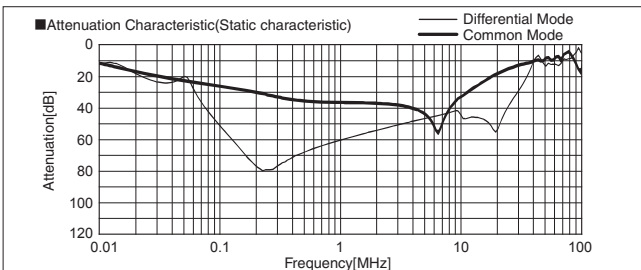

TAH-80-223-U

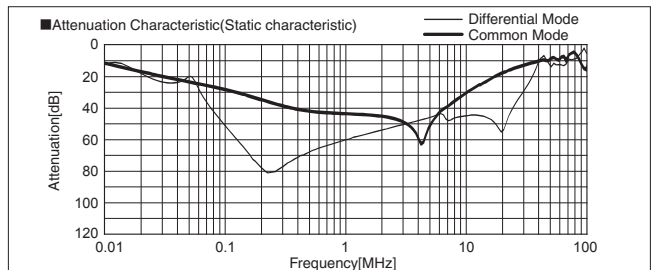

TAH-80-333-U

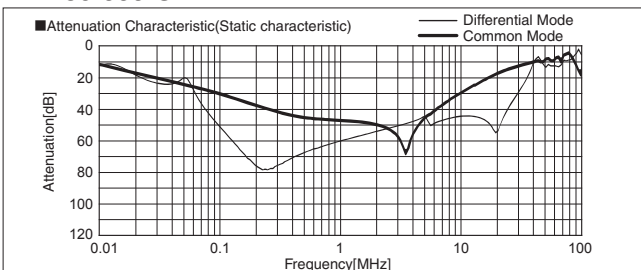

TAC-100-103-U

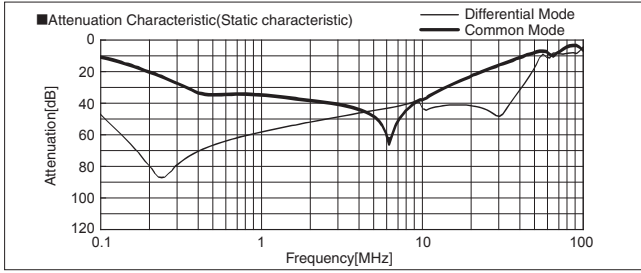

TAC-100-223-U

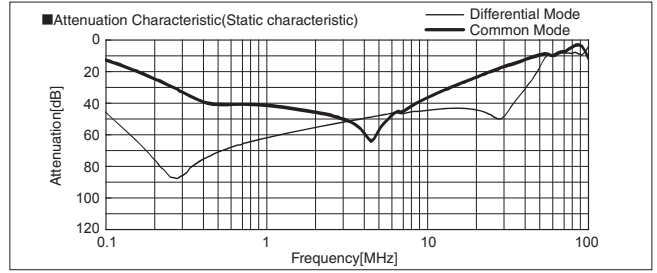

TAC-100-333-U

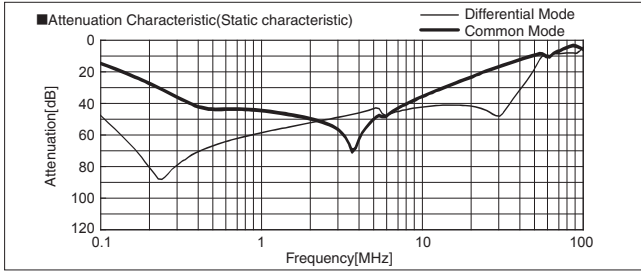

TAC-150-103-U

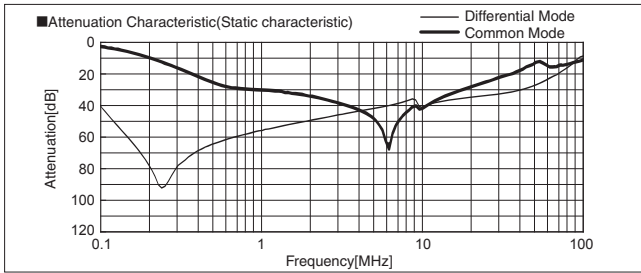

TAC-150-223-U

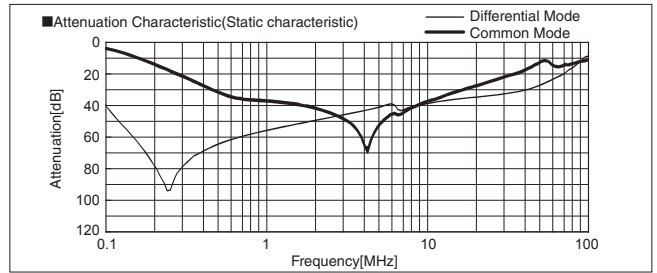

TAC-150-333-U

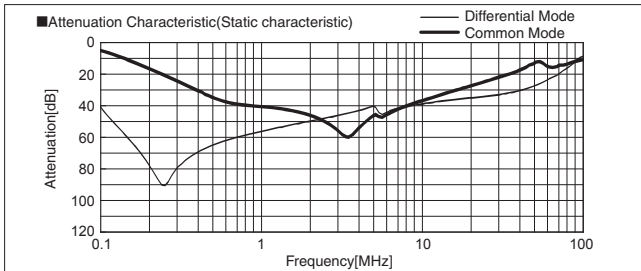

TAH-100-103-U

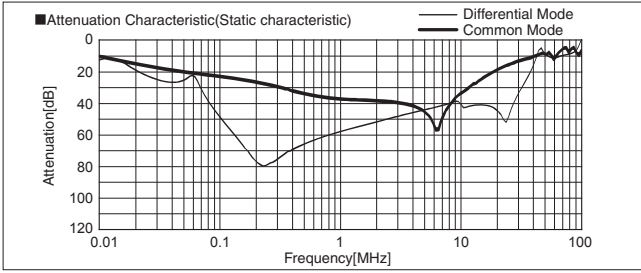

TAH-100-223-U

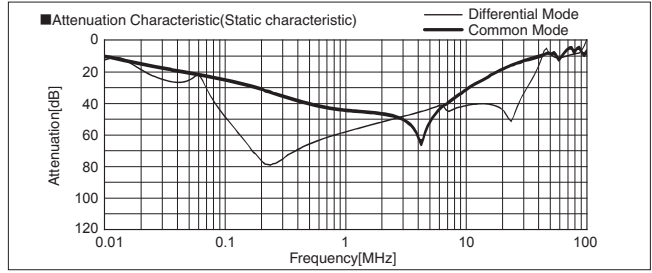

TAH-100-333-U

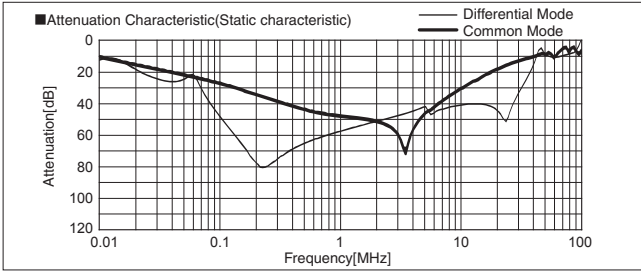

TAH-150-103-U

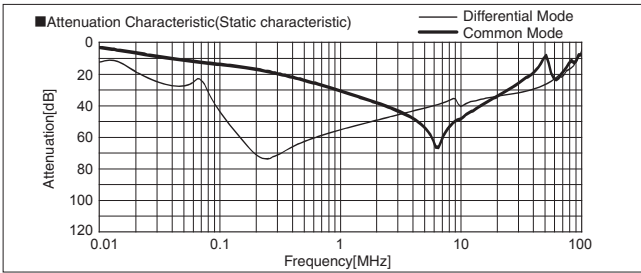

TAH-150-223-U

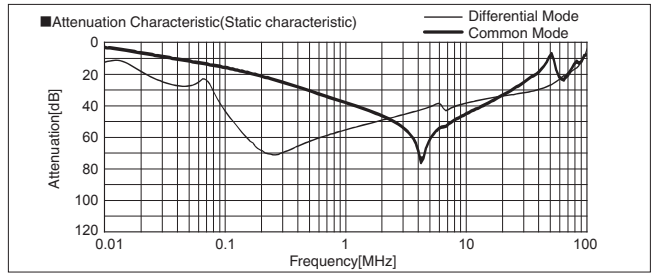

TAH-150-333-U

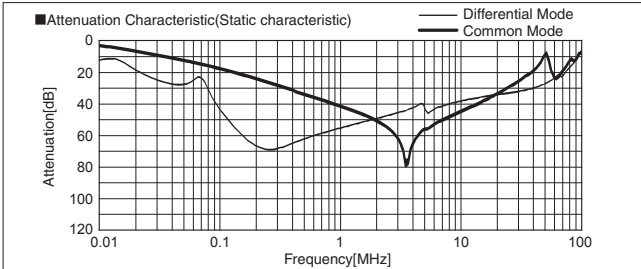

TAC-200-103

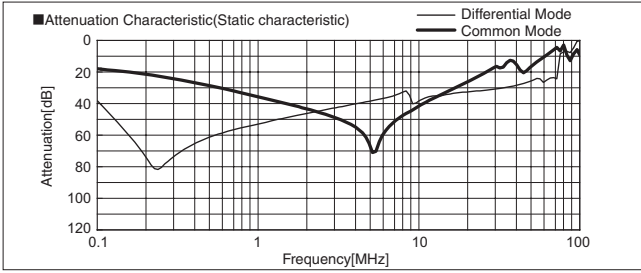

TAC-200-223

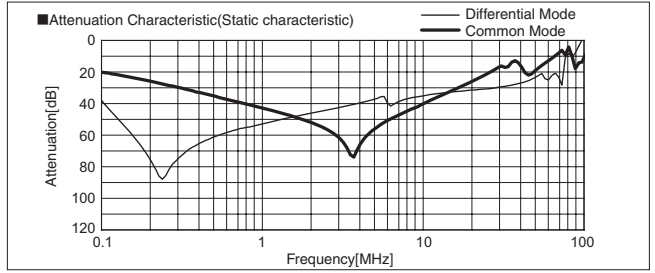

TAC-200-333

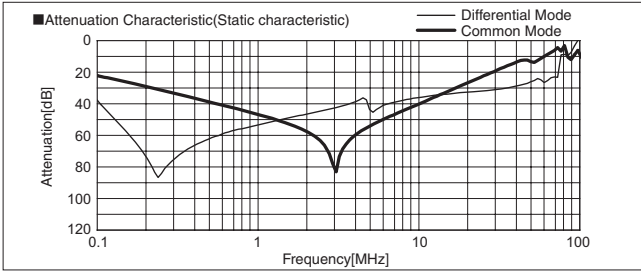

TAC-250-103

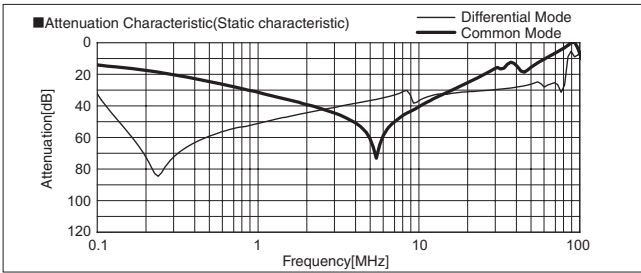

TAC-250-223

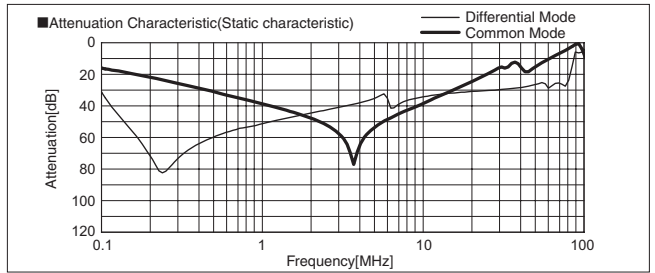

TAC-250-333

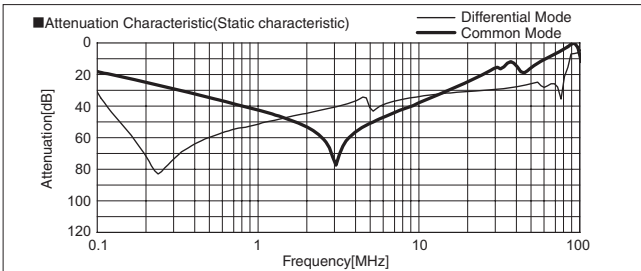

TAC-300-103

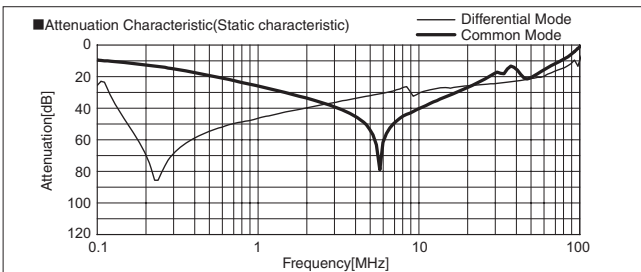

TAC-300-223

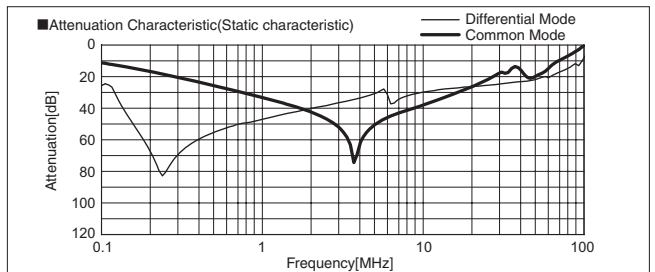

TAC-300-333

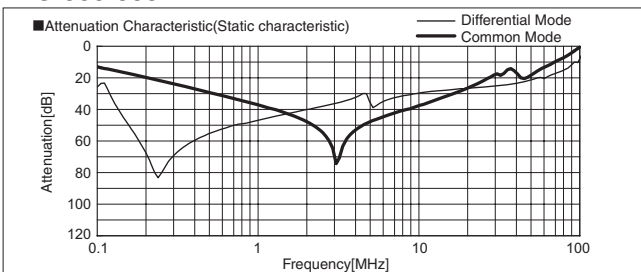

TAC-200-103-U

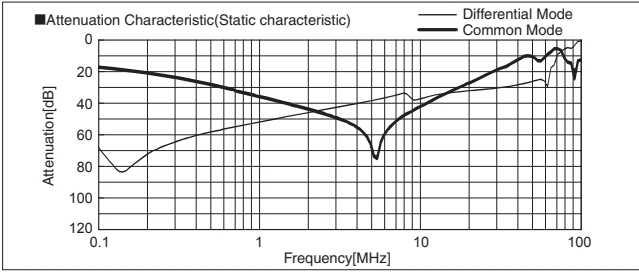

TAC-200-223-U

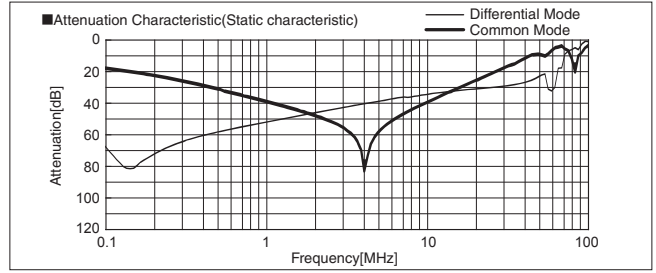

TAC-200-333-U

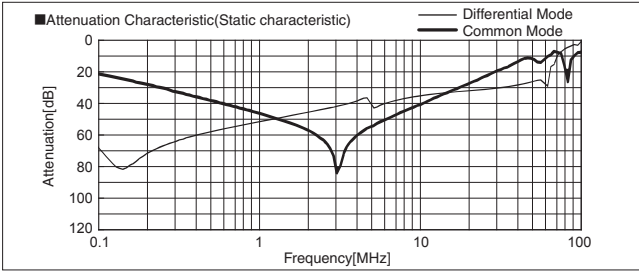

TAC-250-103-U

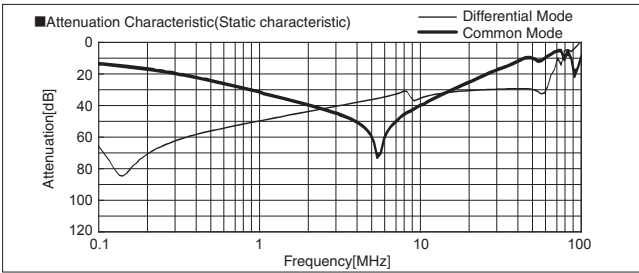

TAC-250-223-U

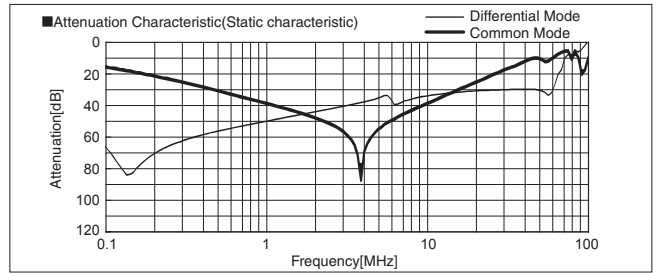

TAC-250-333-U

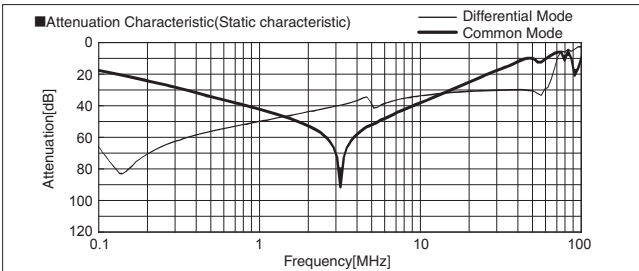

TAC-300-103-U

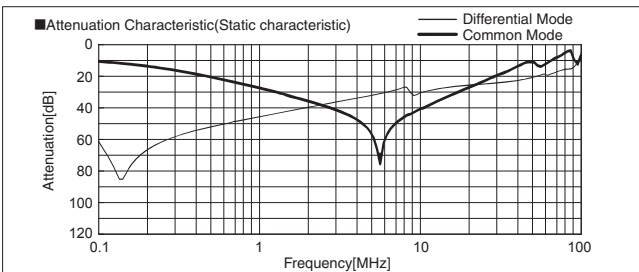

TAC-300-223-U

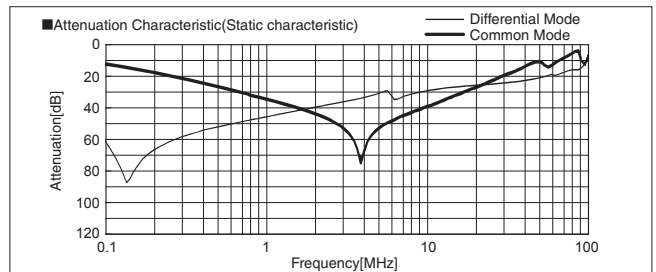

TAC-300-333-U

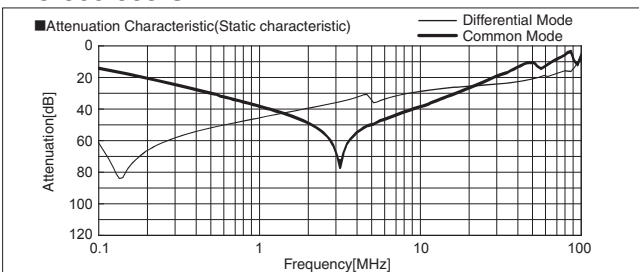

FTA series(40,50,60A)

FTA -50 -683 -□

① ② ③ ④



- ① Model Name
- ② Rated Current
- ③ Line to ground capacitor code: See table 1.1.

table 1.1 Line to ground capacitor code

Code	Leakage Current (Input 250/500V 60Hz) (335 only 250/400V 60Hz)	Line to ground capacitor (nominal value)
223	1.0mA/2.0mA max	22,000pF
683	2.5mA/5.0mA max	68,000pF
104	3.5mA/7.0mA max	100,000pF
335	160mA/250mA max	3.3μF

* When the line to ground capacitor code is different, the attenuation characteristic is different.

- ④ Option
- H: Ultra high attenuation type "335" is not applied.
- U: Improve differential mode attenuation (Rated voltage 250V)
- G: With switch of line to ground capacitor Only "335" is applied.
- * Leakage current 160mA/250mA max when the switch state is ON (switched to "I"). 10μA/16μA max when the switch state is OFF (switched to "O").

Features of FTA series

Book type (Space-saving type)

- 1-stage filter General-purpose High-attenuation (150kHz - 1MHz)
- Selectable leakage current value, Ultra high attenuation type "335" for EU(Wye type with neutral earth system), With switch of line to ground capacitor "-G"

Specifications

No.	Items	FTA-40-683	FTA-50-683	FTA-60-683
1	Rated Voltage[V]	AC Three Phase 500 (voltage range:528 max) 50/60Hz *1 *2		
2	Rated Current[A]	40	50	60
3	Test Voltage (Terminal-Mounting Plate)	2,500 VAC (Cutoff Current = 100mA), 1minute at room temperature and humidity *3		
4	Isolation Resistance (Terminal-Mounting Plate)	500 VDC 100MΩ min at room temperature and humidity *4		
5	Leakage current 250/500V 60Hz	2.5mA/5.0mA max		
6	DC resistance	8.5mΩ max	6mΩ max	4.5mΩ max
7	Safety agency approval temperatures	-25 to +85°C (Refer to Derating Curve)		
8	Operating temperature	-40 to +85°C (Refer to Derating Curve)		
9	Operating humidity	20 to 95%RH (Non condensing)		
10	Storage temperature/humidity	-40 to +85°C/20 to 95%RH (Non condensing)		
11	Vibration	10 to 55Hz, 19.6m/s ² (2G), 3min. Period, 1hour each X, Y and Z axis		
12	Impact	196.1m/s ² (20G), 11ms Once each X, Y and Z axis		
13	Safety agency approvals	UL1283, CSA C22.2 No.8 (C-UL) , DIN EN60939 VDE0565 Teil3-1, ENEC		
14	Case size (without projection)	65 X 84 X 153 mm (W X H X D) (Option: -G refer to external view) [2.56 X 3.31 X 6.02 inches] (W X H X D)		
15	Weight	1.2kg max		

*1 Only capacitor code "335", Three Phase Δ-connection : 400 (440 max), Wye-connection : 500 (528 max)

*2 Only "FTA-□□□□□□-U", Three Phase 250 (275 max)

*3 Only capacitor code "335", 2,800VDC (Cutoff Current = 10mA), 1minute at room temperature and humidity.

*4 Only capacitor code "335", Isolation resistance specification is deleted.

Circuit Diagram

(1) Line to ground capacitor code : 223, 683, 104

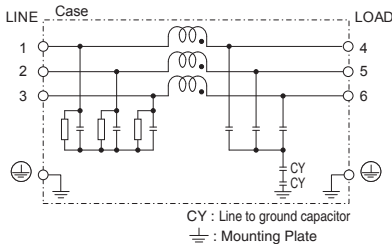

(2) Line to ground capacitor code : 335

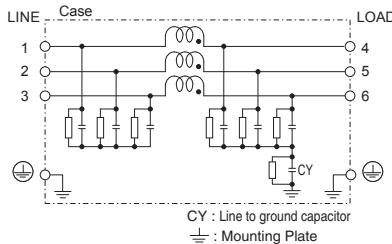

(3) Line to ground capacitor code : 223, 683, 104
Option : U

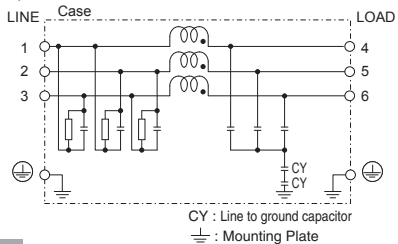

(4) FTA-□□□□-335-U

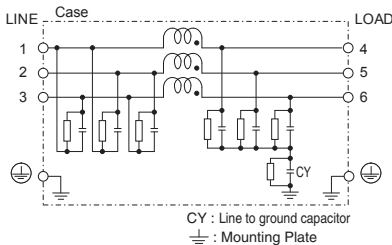

(5) FTA-□□□□-335-G

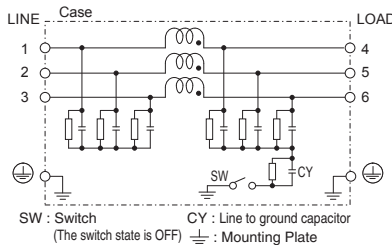

Derating Curve

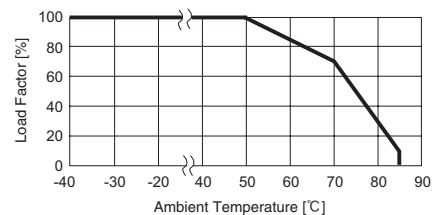

External view

Standard Type

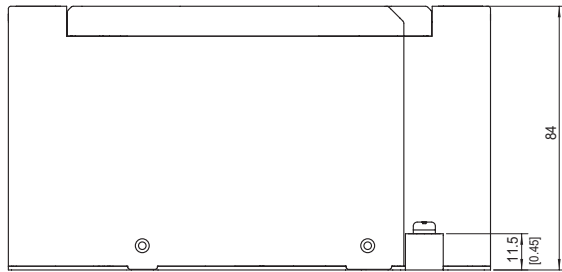
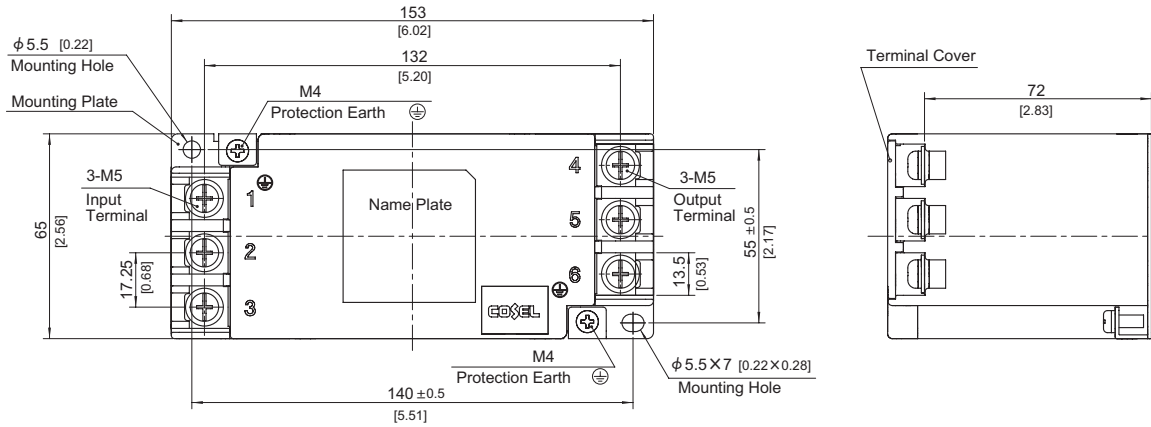

- ※ Tolerance : ± 1 [± 0.04]
- ※ Weight : 1.2kg max
- ※ Mounting Plate : Iron (surface finishing : nickel plating) $t=1.2$ [0.05]
- ※ Case : PBT
- ※ Dimensions in mm, []=inches
- ※ Terminal block screw tightening torque M5 : $3.0N \cdot m$ (30.7kgf · cm)max
- ※ Protection Earth (PE) screw tightening torque M4 : $1.6N \cdot m$ (16.9kgf · cm)max
- ※ Can not be mounted upside-down (mounted the top surface)

With switch of line to ground capacitor ON/OFF

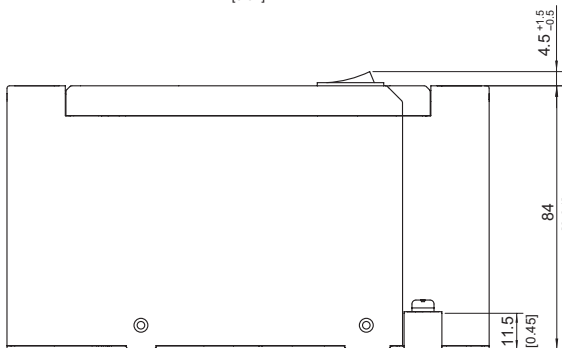
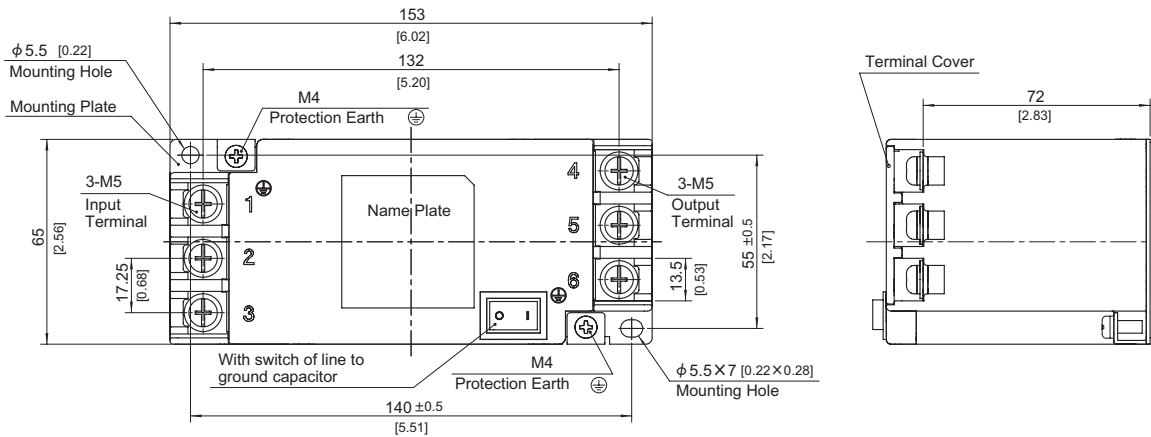

- ※ Tolerance : ± 1 [± 0.04]
- ※ Weight : 1.2kg max
- ※ Mounting Plate : Iron (surface finishing : nickel plating) $t=1.2$ [0.05]
- ※ Case : PBT
- ※ Dimensions in mm, []=inches
- ※ Terminal block screw tightening torque M5 : $3.0N \cdot m$ (30.7kgf · cm)max
- ※ Protection Earth (PE) screw tightening torque M4 : $1.6N \cdot m$ (16.9kgf · cm)max
- ※ Can not be mounted upside-down (mounted the top surface)
- ※ The switch state is OFF at shipping
- ※ Switch status ON : "I", OFF : "O"

※ **HIGH LEAKAGE CURRENT**
first connect to earth

FTA-40-223-H

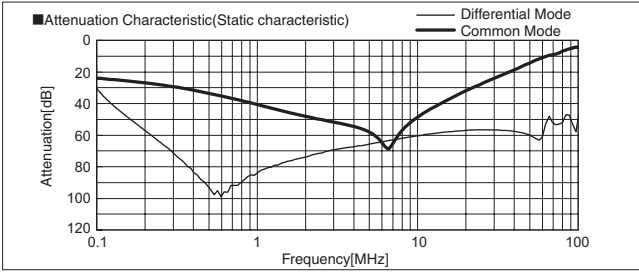

FTA-40-683-H

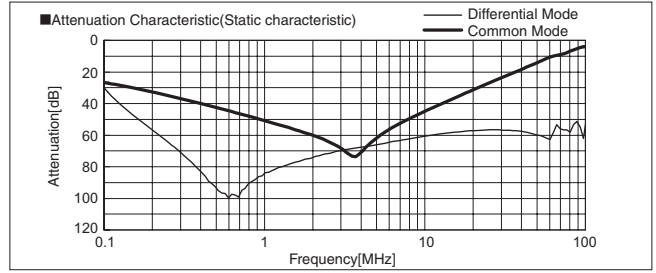

FTA-40-104-H

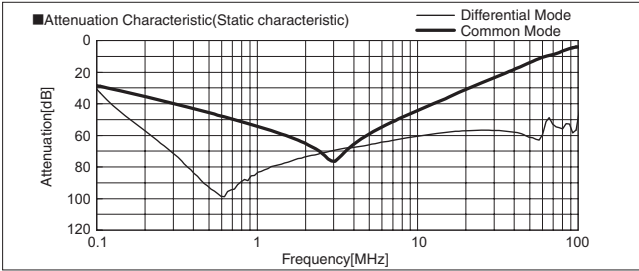

FTA-50-223-H

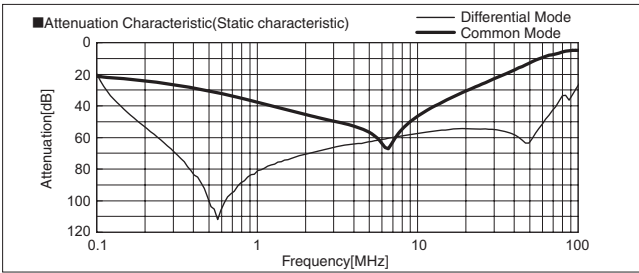

FTA-50-683-H

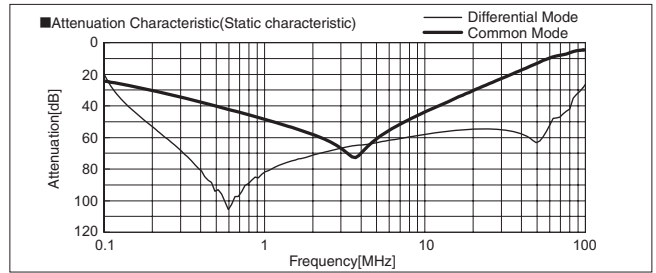

FTA-50-104-H

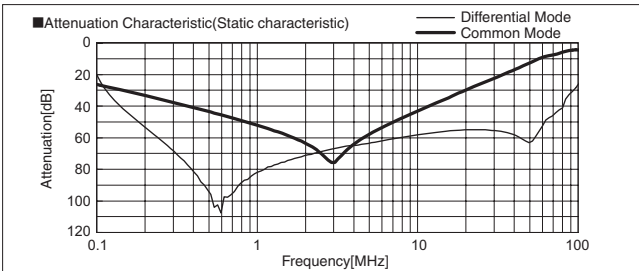

FTA-60-223-H

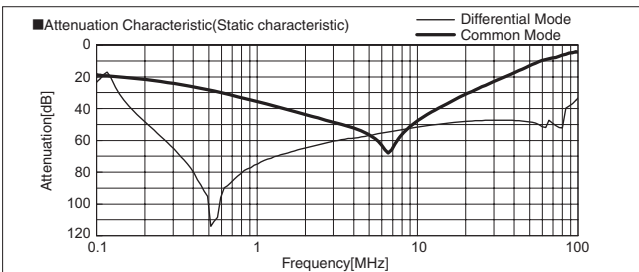

FTA-60-683-H

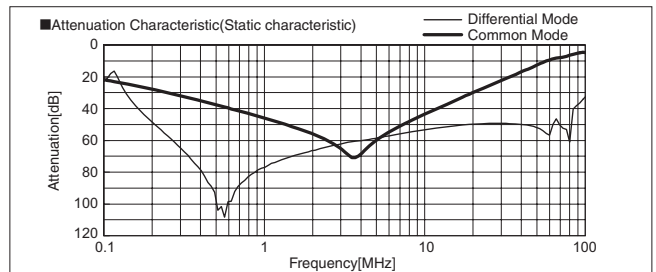

FTA-60-104-H

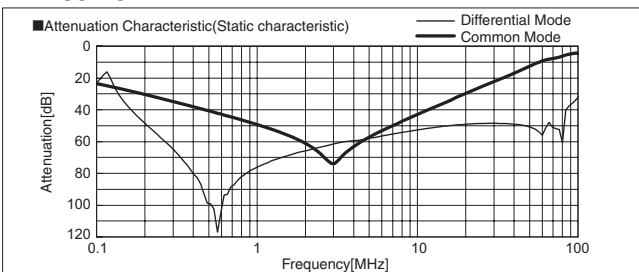

FTA-40-223-U

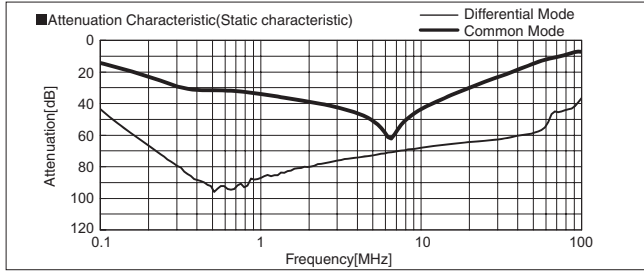

FTA-40-683-U

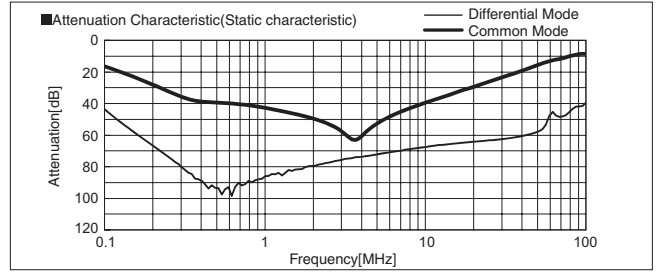

FTA-40-104-U

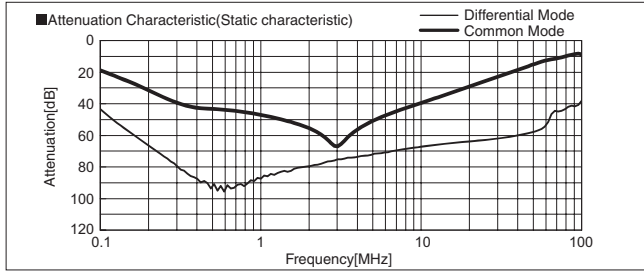

FTA-40-335-U

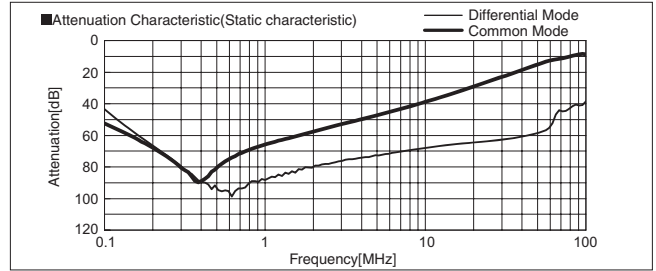

FTA-50-223-U

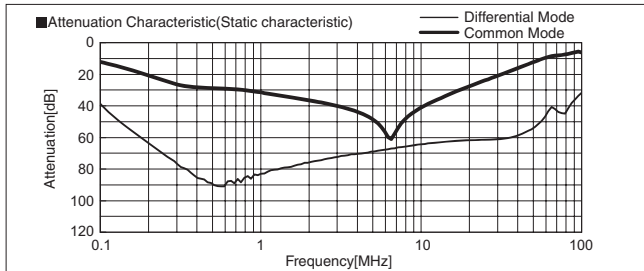

FTA-50-683-U

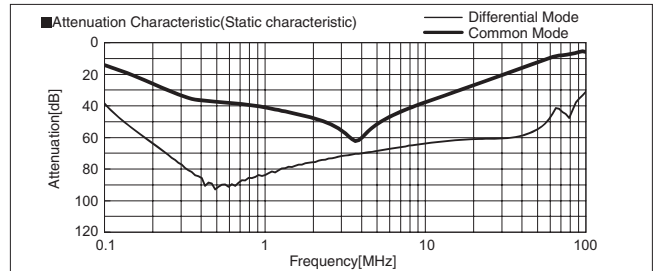

FTA-50-104-U

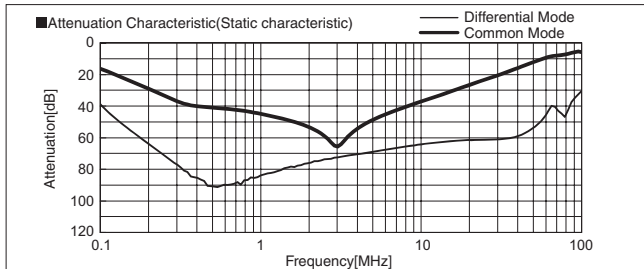

FTA-50-335-U

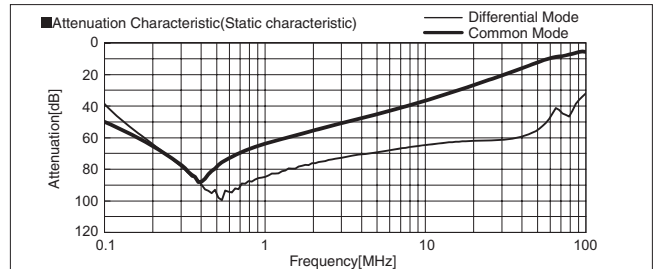

FTA-60-223-U

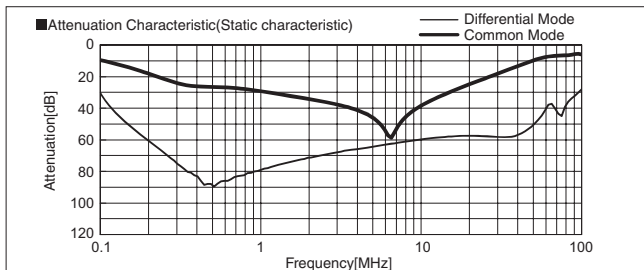

FTA-60-683-U

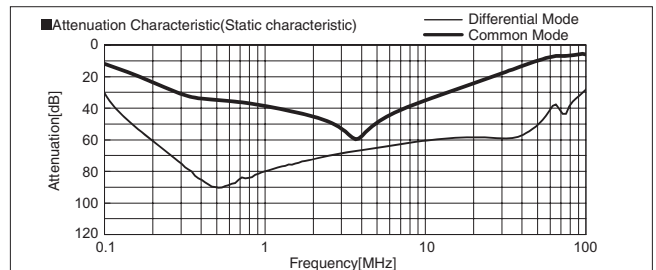

FTA-60-104-U

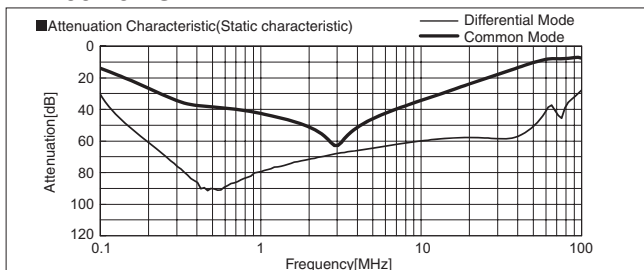

FTA-60-335-U

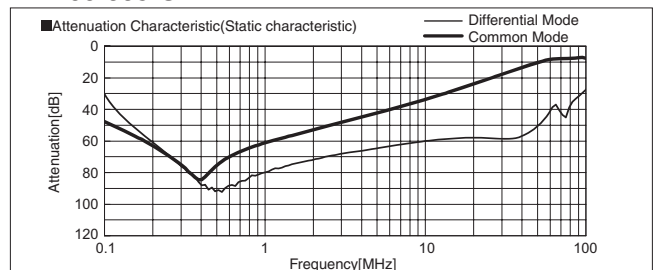

FTA series(80,100,125,150A)

FTA -80 -683 -□

① ② ③ ④

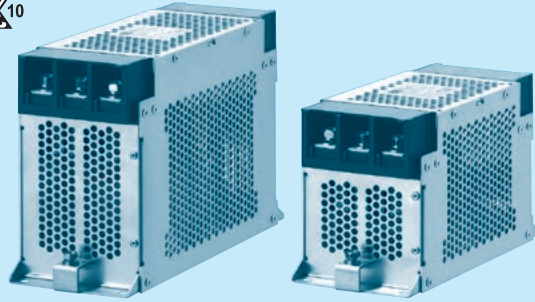

- ① Model Name
- ② Rated Current
- ③ Line to ground capacitor code: See table 1.1.

Code	Leakage Current (Input 250/500V 60Hz) (155,335 only 250/400V 60Hz)	Line to ground capacitor (nominal value)
223	1.0mA/2.0mA max	22,000pF
683	2.5mA/5.0mA max	68,000pF
104	3.5mA/7.0mA max	100,000pF
155	160mA/250mA max	1.5μF
335	320mA/500mA max	3.3μF

* When the line to ground capacitor code is different, the attenuation characteristic is different.

- ④ Option
- H: Ultra high attenuation type
"155", "335" is not applied.
- S: Hexagon socket head cap screw
(Standard type is Hexagon head screw)
- U: Improve differential mode attenuation
(Rated voltage 250V)
- G: With switch of line to ground capacitor
Only "155", "335" is applied.
- * "155" is Leakage current 160mA/250mA max when the switch state is ON (switched to "I").
50μA/80μA max when the switch state is OFF (switched to "O").
- * "335" is Leakage current 320mA/500mA max when the switch state is ON (switched to "I").
50μA/80μA max when the switch state is OFF (switched to "O").

Features of FTA series

Book type (Space-saving type)

- 1-stage filter General-purpose High-attenuation (150kHz - 1MHz)
- Selectable leakage current value, Ultra high attenuation type "155", "335" for EU
(Wye type with neutral earth system), With switch of line to ground capacitor "-G"

Specifications

No.	Items	FTA-80-683	FTA-100-683	FTA-125-683	FTA-150-683
1	Rated Voltage[V]	AC Three phase 500 (voltage range:528 max) 50/60Hz *1 *2			
2	Rated Current[A]	80	100	125	150
3	Test Voltage (Terminal-Mounting Plate)	2,500 VAC (Cutoff Current = 100mA), 1minute at room temperature and humidity *3			
4	Isolation Resistance (Terminal-Mounting Plate)	500 VDC 100MΩ min at room temperature and humidity *4			
5	Leakage current 250/500V 60Hz	2.5mA/5.0mA max			
6	DC resistance	5mΩ max	4mΩ max	3mΩ max	3mΩ max
7	Safety agency approval temperatures	-25 to +85°C (Refer to Derating Curve)			
8	Operating temperature	-40 to +85°C (Refer to Derating Curve)			
9	Operating humidity	20 to 95%RH (Non condensing)			
10	Storage temperature/humidity	-40 to +85°C/20 to 95%RH (Non condensing)			
11	Vibration	10 to 55Hz, 19.6m/s ² (2G), 3min. Period, 1hour each X, Y and Z axis			
12	Impact	196.1m/s ² (20G), 11ms Once each X, Y and Z axis			
13	Safety agency approvals	UL1283, CSA C22.2 No.8 (C-UL), DIN EN60939 VDE0565 Teil3-1, ENEC			
14	Case size (without projection)	100 X 130 X 210 mm (W X H X D) (Option: -G refer to external view)			100 X 170 X 260 mm (W X H X D) (Option: -G refer to external view)
		[3.94 X 5.12 X 8.27 inches]			[3.94 X 6.69 X 10.24 inches]
15	Weight	3.1kg max			4.2kg max

*1 Only capacitor code and option "155", "335", Three Phase Δ-connection: 400 (440 max), Wye-connection: 500 (528 max)

*2 Only option "U", Three Phase 250 (275 max)

*3 Only capacitor code and option "155", "335", 2,800VDC (Cutoff Current = 10mA), 1minute at room temperature and humidity.

*4 Only capacitor code and option "155", "335", Isolation resistance specification is deleted.

Circuit Diagram

(1) Line to ground capacitor code : 223, 683, 104

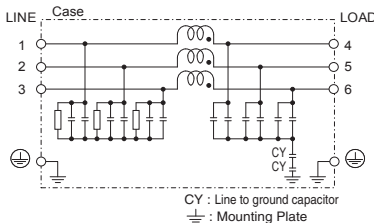

(2) Line to ground capacitor code : 155, 335

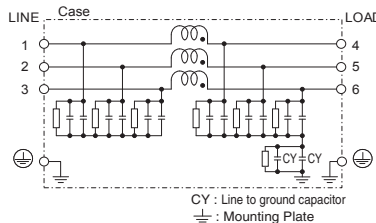

(3) Line to ground capacitor code : 223, 683, 104
Option : U

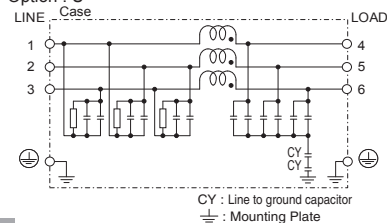

(4) Line to ground capacitor code : 155, 335
Option : U

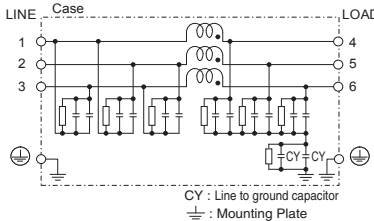

(5) Line to ground capacitor code : 155, 335
Option : G

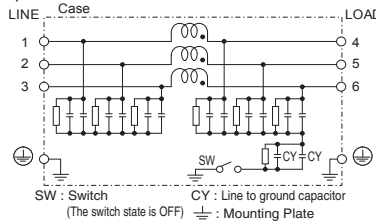

Derating Curve

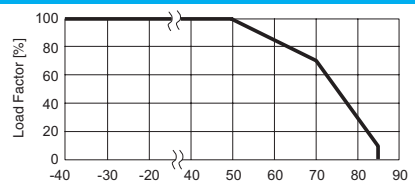

* Keep free ventilation holes for cooling.

External view

FTA-80 / FTA-100 / FTA-125

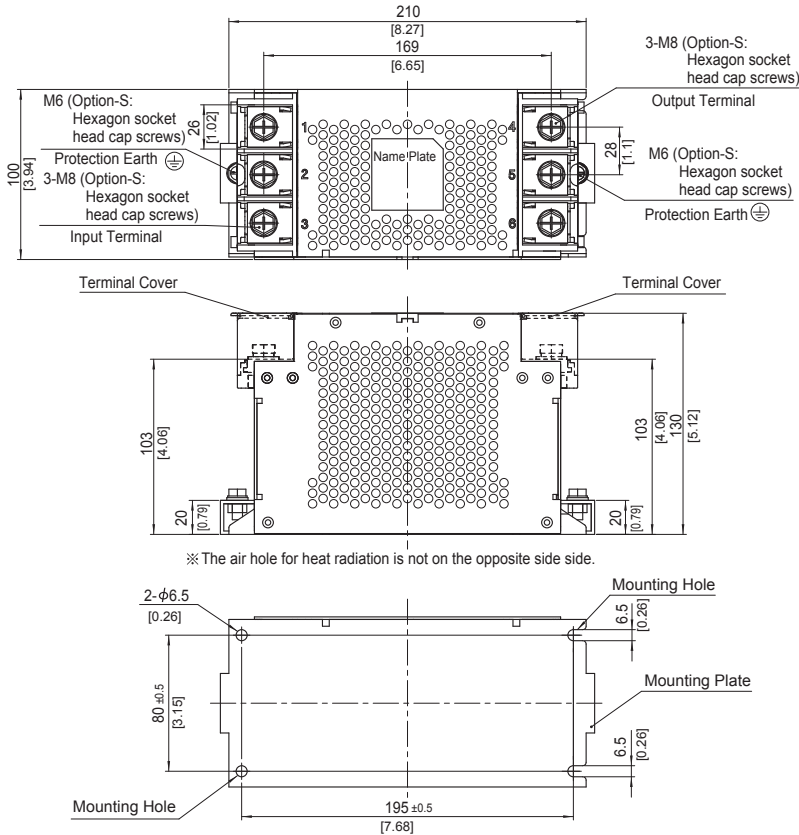

※ The air hole for heat radiation is not on the opposite side.

- ※ Tolerance : ±1 [±0.04]
- ※ Weight : 3.1kg max
- ※ Mounting Plate : Aluminum t=2.0 [0.08]
- ※ Dimensions in mm, []=inches
- ※ Terminal block screw tightening torque
M8 : 9.2N · m(93.9kgf · cm)max
- ※ Protection Earth (PE) screw tightening torque
M6 : 5.8N · m(59.2kgf · cm)max
- ※ Can not be mounted upside-down
(mounted the top surface)
- ※ Keep free ventilation holes for cooling

FTA-80 / FTA-100 / FTA-125 with switch of line to ground capacitor ON/OFF

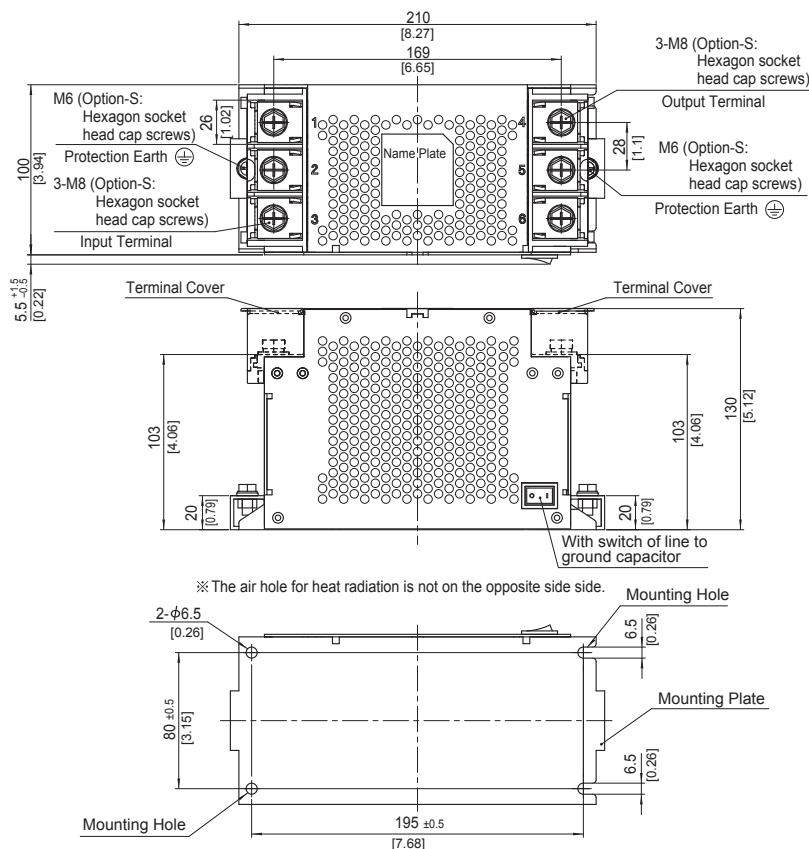

※ The air hole for heat radiation is not on the opposite side.

- ※ Tolerance : ±1 [±0.04]
- ※ Weight : 3.1kg max
- ※ Mounting Plate : Aluminum t=2.0 [0.08]
- ※ Dimensions in mm, []=inches
- ※ Terminal block screw tightening torque
M8 : 9.2N · m(93.9kgf · cm)max
- ※ Protection Earth (PE) screw tightening torque
M6 : 5.8N · m(59.2kgf · cm)max
- ※ Can not be mounted upside-down
(mounted the top surface)
- ※ Keep free ventilation holes for cooling
- ※ The switch state is OFF at shipping
- ※ Switch status ON : "I", OFF : "O"
- ※ HIGH LEAKAGE CURRENT
first connect to earth

External view

FTA-150

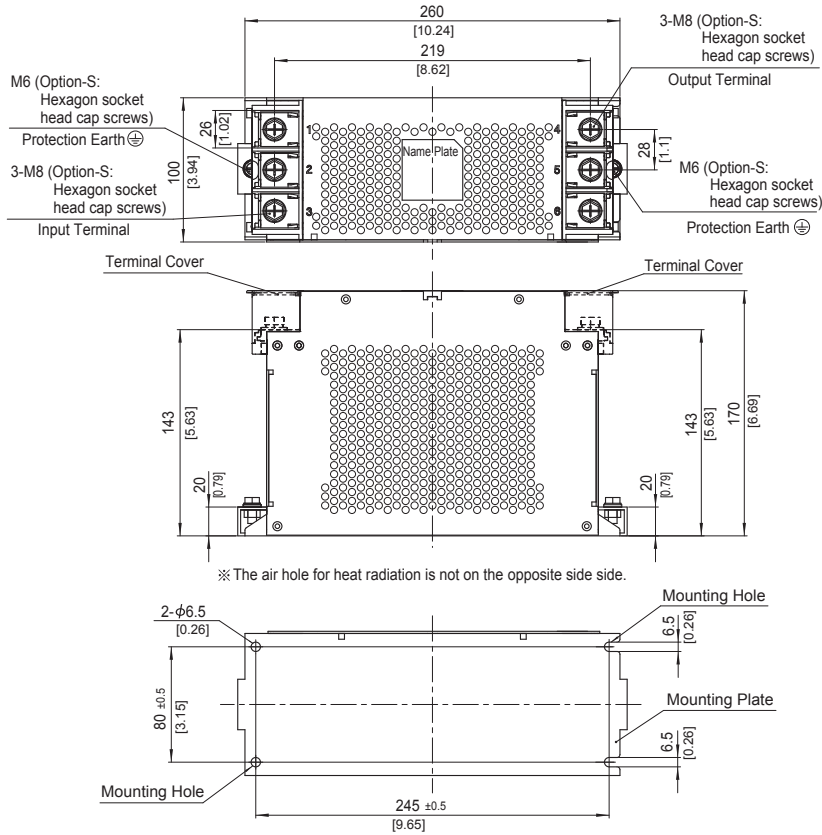

- ※ Tolerance : ± 1 [± 0.04]
- ※ Weight : 4.2kg max
- ※ Mounting Plate : Aluminum $t=2.0$ [0.08]
- ※ Dimensions in mm, []=inches
- ※ Terminal block screw tightening torque
M8 : $9.2N \cdot m$ (93.9kgf \cdot cm)max
- ※ Protection Earth (PE) screw tightening torque
M6 : $5.8N \cdot m$ (59.2kgf \cdot cm)max
- ※ Can not be mounted upside-down (mounted the top surface)
- ※ Keep free ventilation holes for cooling

FTA-150 with switch of line to ground capacitor ON/OFF

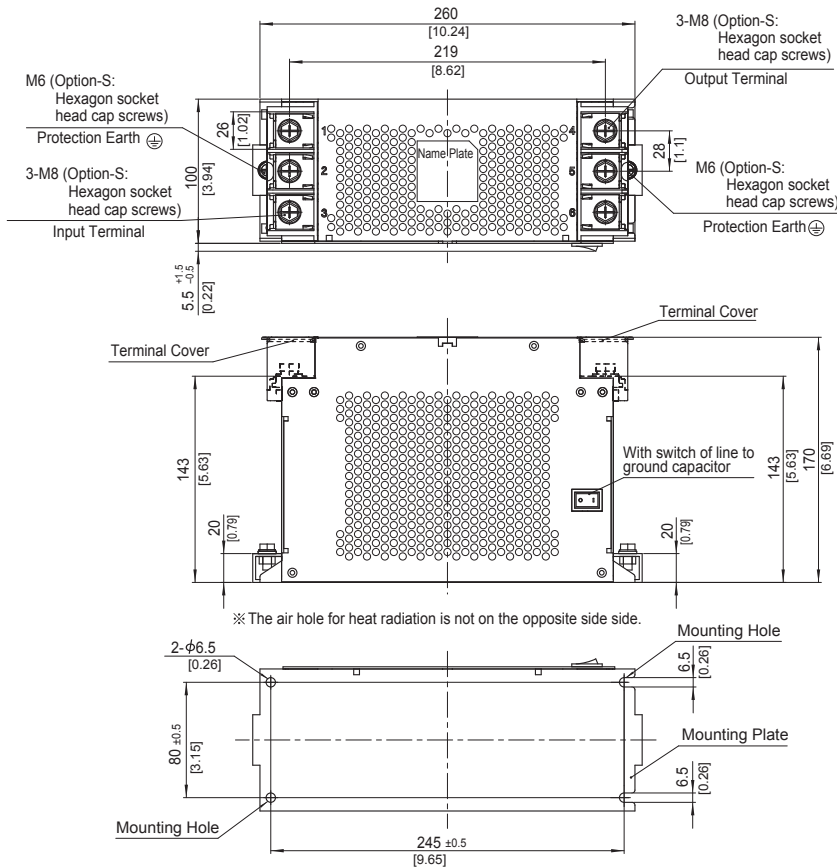

- ※ Tolerance : ± 1 [± 0.04]
- ※ Weight : 4.2kg max
- ※ Mounting Plate : Aluminum $t=2.0$ [0.08]
- ※ Dimensions in mm, []=inches
- ※ Terminal block screw tightening torque
M8 : $9.2N \cdot m$ (93.9kgf \cdot cm)max
- ※ Protection Earth (PE) screw tightening torque
M6 : $5.8N \cdot m$ (59.2kgf \cdot cm)max
- ※ Can not be mounted upside-down (mounted the top surface)
- ※ Keep free ventilation holes for cooling
- ※ The switch state is OFF at shipping
- ※ Switch status ON : " | ", OFF : " O "
- ※ HIGH LEAKAGE CURRENT first connect to earth

FTA-80-223

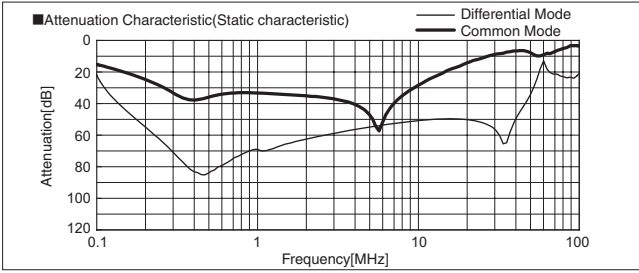

FTA-80-683

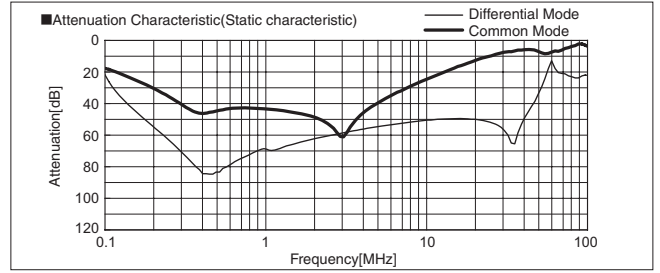

FTA-80-104

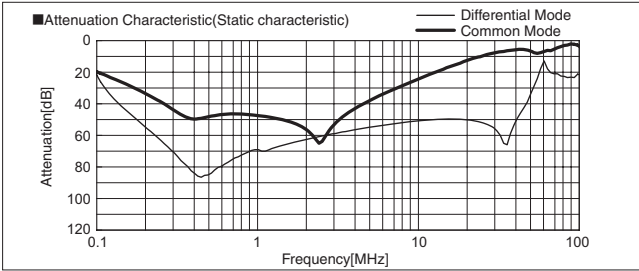

FTA-80-155



FTA-80-335

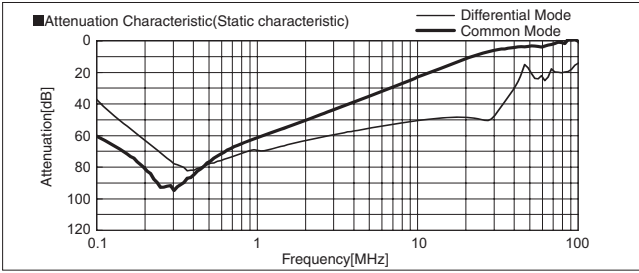

FTA-100-223

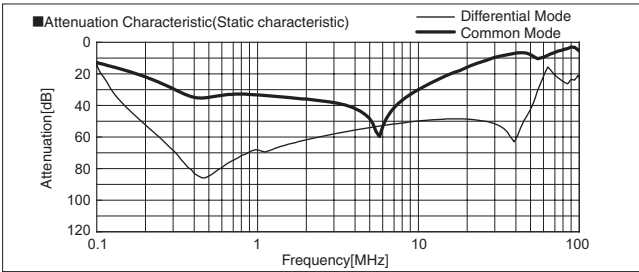

FTA-100-683

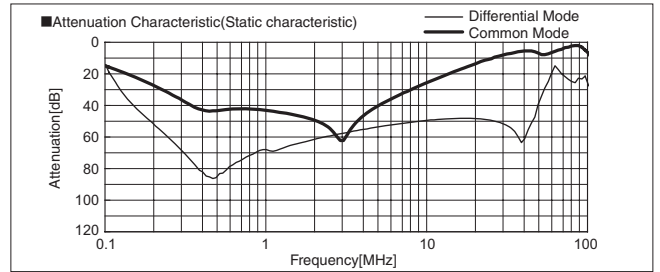

FTA-100-104

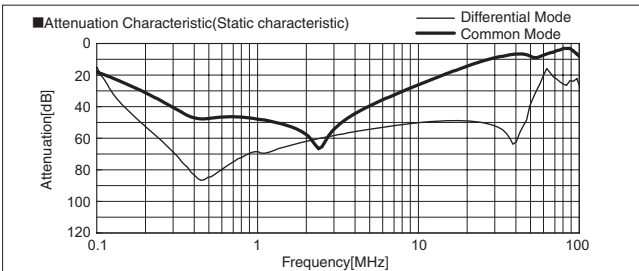

FTA-100-155

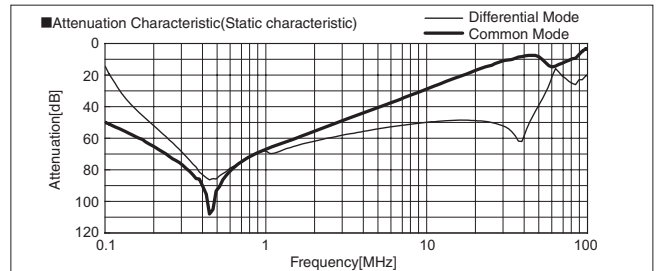

FTA-100-335

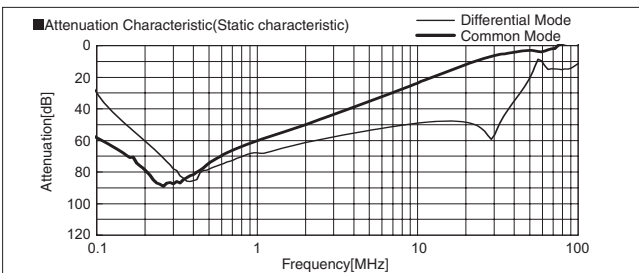

FTA-80-223-H

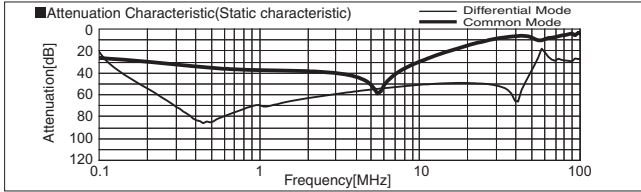

FTA-80-683-H

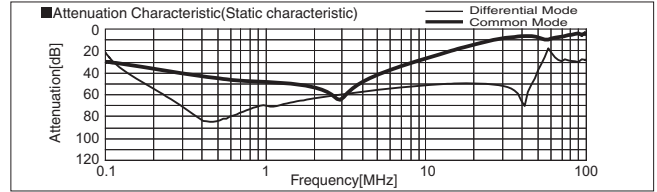

FTA-80-104-H

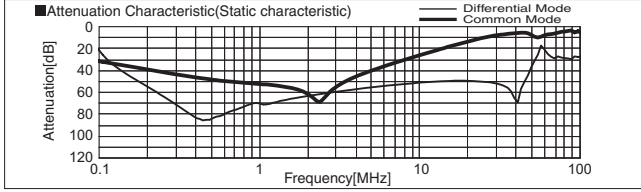

FTA-100-223-H

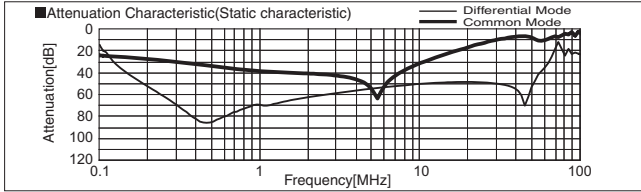

FTA-100-683-H

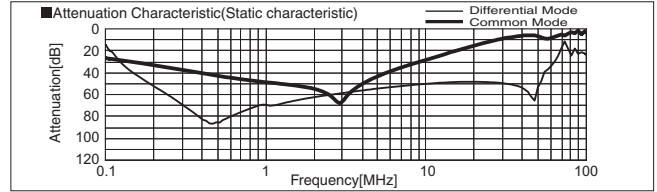

FTA-100-104-H

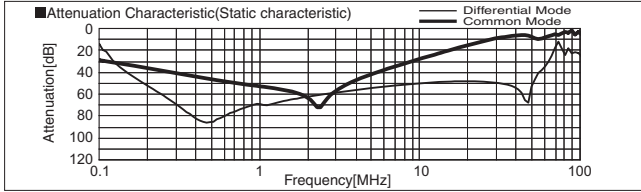

FTA-125-223-H

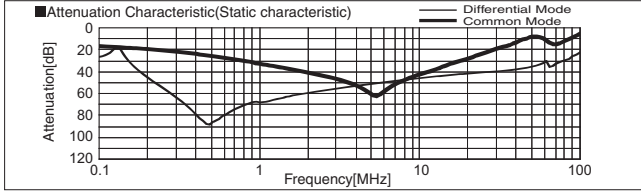

FTA-125-683-H

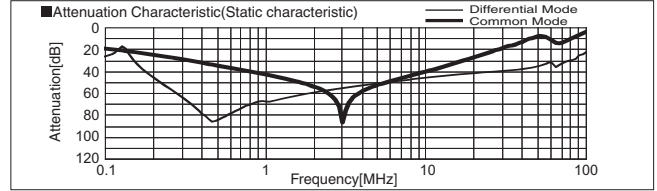

FTA-125-104-H

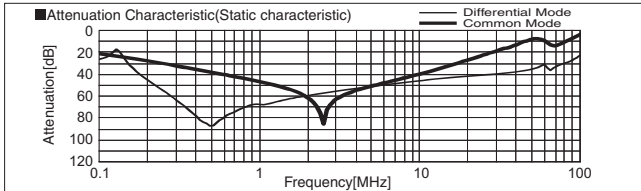

FTA-150-223-H

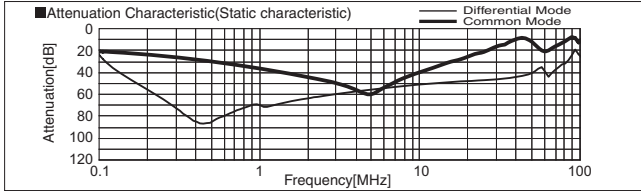

FTA-150-683-H

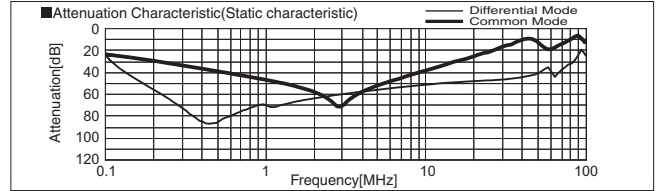

FTA-150-104-H

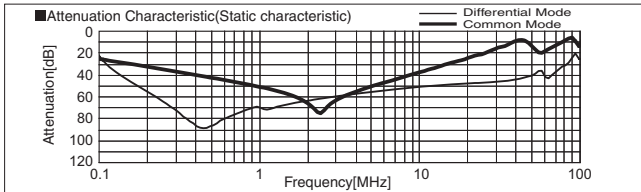

FTA-80-223-U

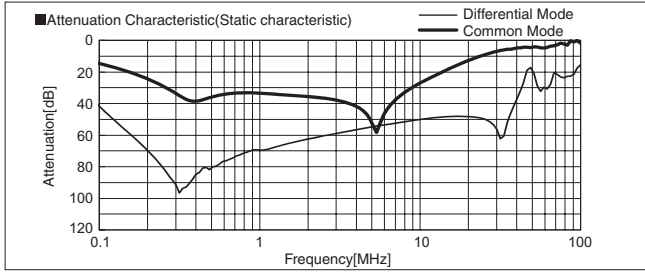

FTA-80-683-U

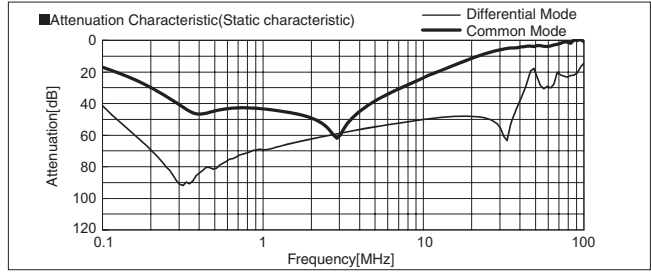

FTA-80-104-U

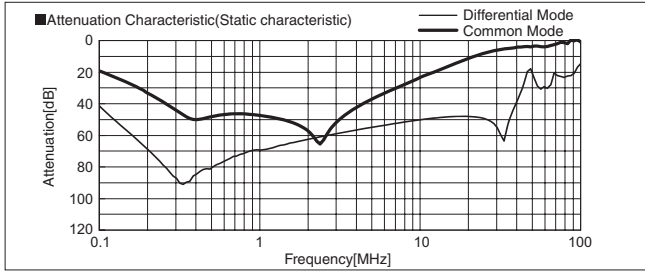

FTA-80-155-U

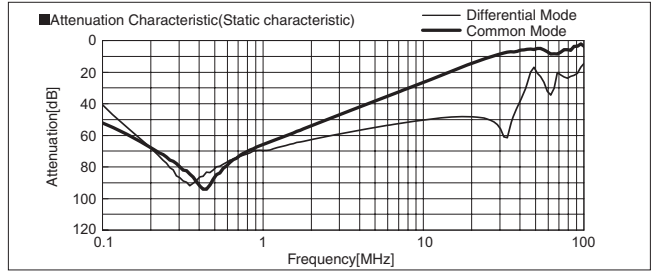

FTA-80-335-U

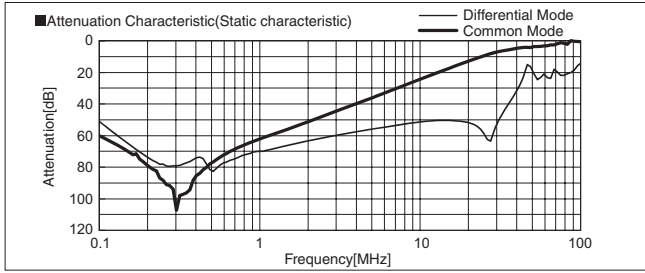

FTA-100-223-U

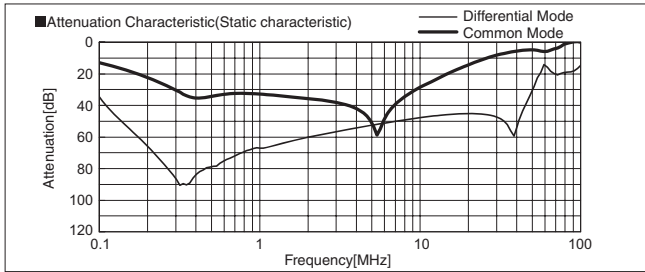

FTA-100-683-U

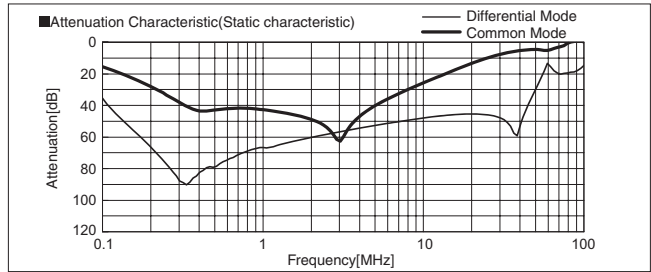

FTA-100-104-U

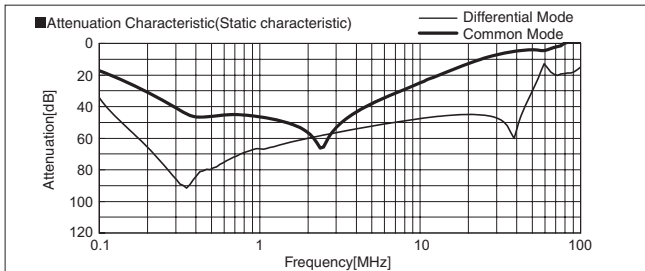

FTA-100-155-U

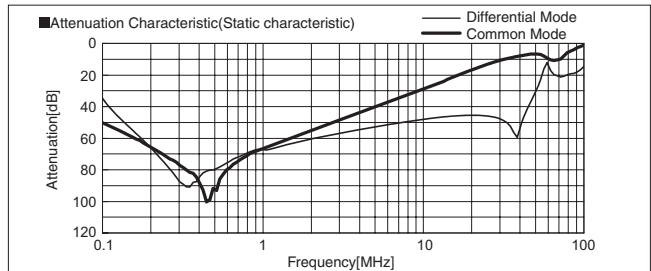

FTA-100-335-U

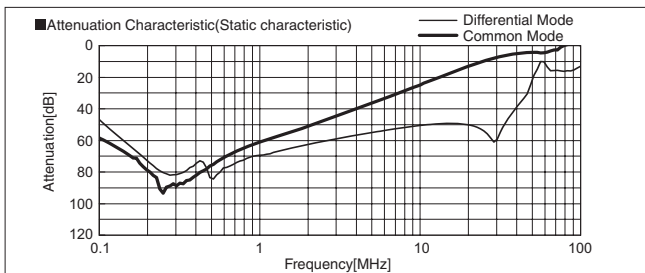

FTA-125-223-U

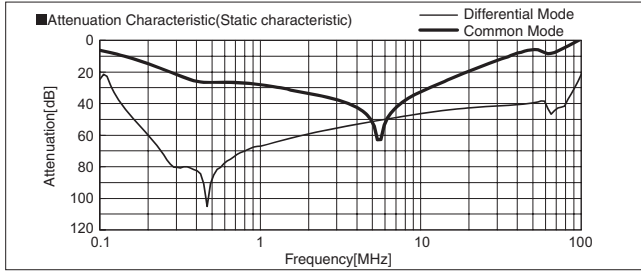

FTA-125-683-U

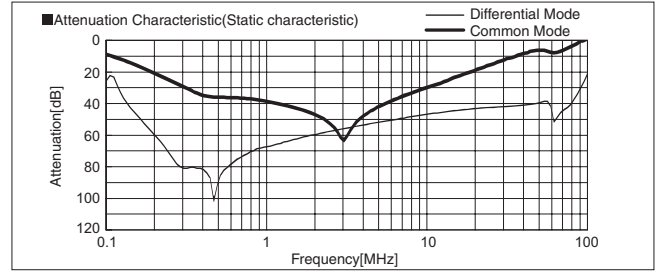

FTA-125-104-U

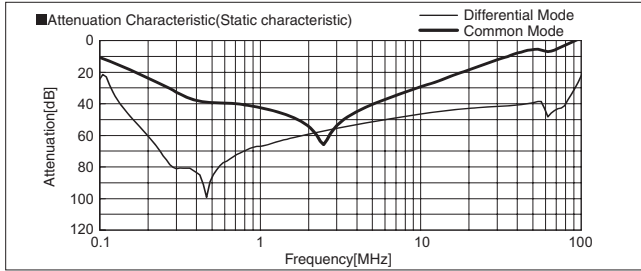

FTA-125-155-U

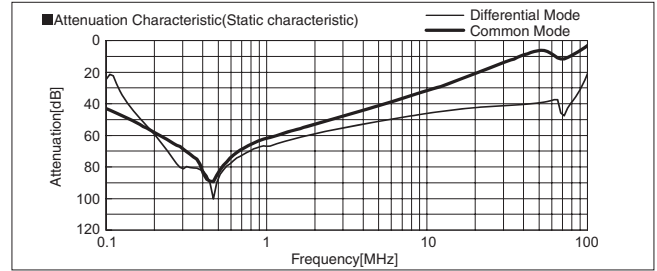

FTA-125-335-U

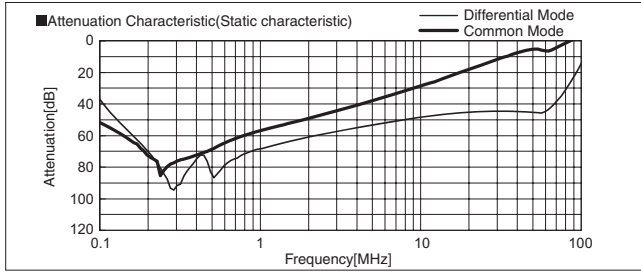

FTA-150-223-U

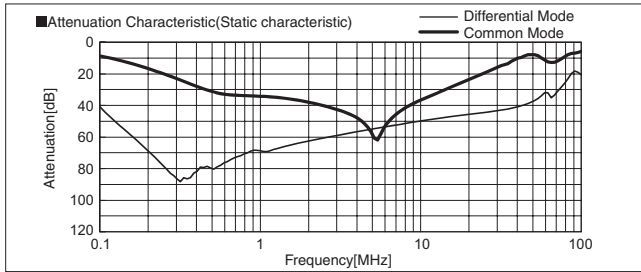

FTA-150-683-U

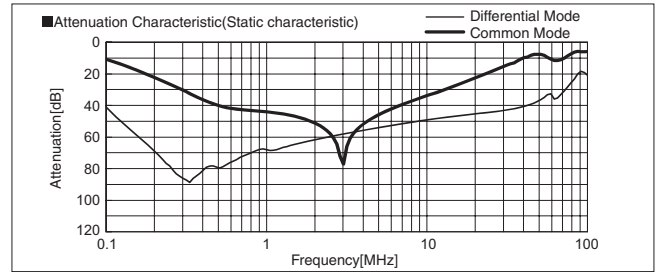

FTA-150-104-U

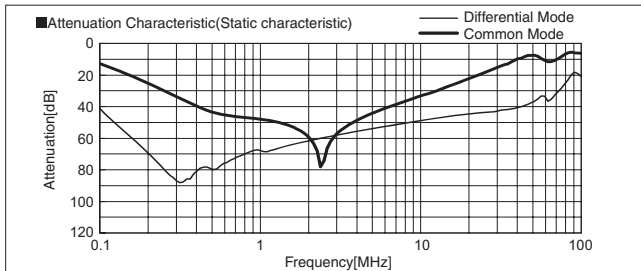

FTA-150-155-U

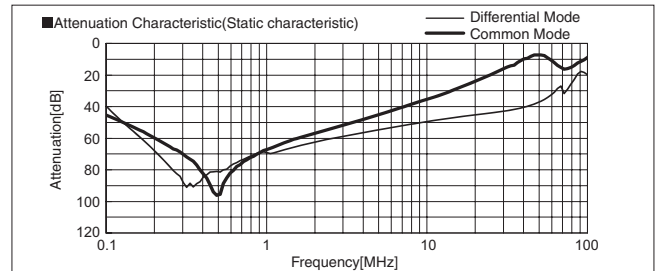

FTA-150-335-U

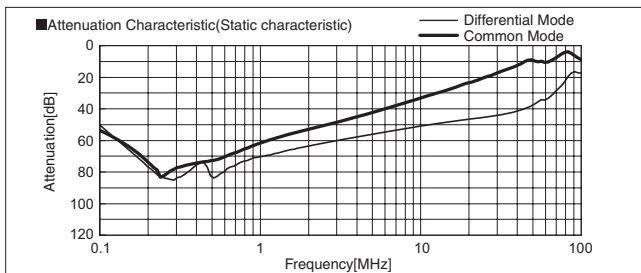

YAC series(25,36,64,80A)

YAC -25 -685



- ① Series Name
- ② Rated Current
- ③ Line to Ground Capacitor Code: See Table 1.1.

Table 1.1. Line to Ground Capacitor Code

Code	Leakage Current Y-Connection	Line to Ground Capacitor (Nominal Value)
685	10.7mA typ *1 55mA max *2	6.8μF

*1 At normal operation (Input 500V 50Hz) with applying 10V in between N (N') and FG (According to IEC60939).

*2 At the worst case under normal operation (Input 500V 60Hz).

Features of YAC series

- Three-Phase Four-Wire System EMI/EMC Filter ideal for High-power office equipment and Energy storage systems
- Suitable for 150kHz to 1MHz conduction noise reduction
- Product lineup that can flexibly respond to system and capacity changes in a compact/same body size

Specifications

No.	Items	YAC-25-685	YAC-36-685	YAC-64-685	YAC-80-685
1	Rated Voltage[VAC]	Three-Phase Four-Wire System Y-Connection 500/289 (Voltage Range:528/305 max) 50/60Hz *3			
2	Rated Current[A]	25	36	64	80
3	Test Voltage (Terminal-Mounting Plate)	2,800 VDC (Cutoff Current = 10mA), 1minute at room temperature and humidity			
4	Isolation Resistance (Terminal-Mounting Plate)	500 VDC 5MΩ min. at room temperature and humidity			
5	Leakage Current	Refer to table 1.1			
6	DC Resistance	15mΩ max	10mΩ max	3.5mΩ max	2.5mΩ max
7	Operating Temperature/Humidity	-40 to +85°C (Refer to Derating Curve)/20 to 95%RH (Non condensing)			
8	Storage Temperature/Humidity	-40 to +85°C/20 to 95%RH (Non condensing)			
9	Vibration	10 to 55Hz, 19.6m/s ² (2G), 3min. Period, 1hour each X, Y and Z axis			
10	Impact	196.1m/s ² (20G), 11ms Once each X, Y and Z axis			
11	Safety Agency Approvals	UL60939 [Overvoltage Category : III Altitude : 3000m] , CSA C22. 2 No. 8 (C-UL) EN60939 (DEMKO) [Overvoltage Category : III Altitude : 3000m] , ENEC			
12	Case Size (Without Projection)	100×88×179mm (W×H×D) [3.94×3.46×7.05 inches] (W×H×D)			
13	Weight	1.7kg max			

*3 Voltage indicates "Line Voltage/Phase Voltage".

Circuit Diagram

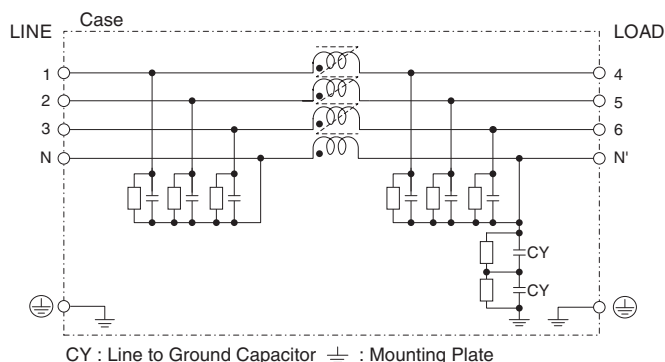

Derating Curve

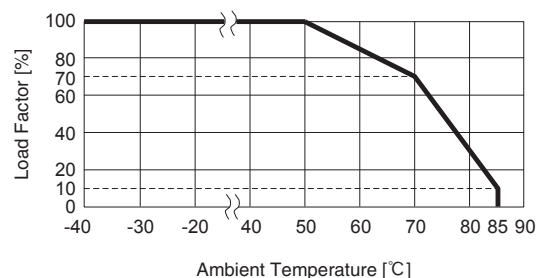

*Keep free ventilation holes for cooling.

External view

This product is shipped with the terminal cover retracted inside the unit.

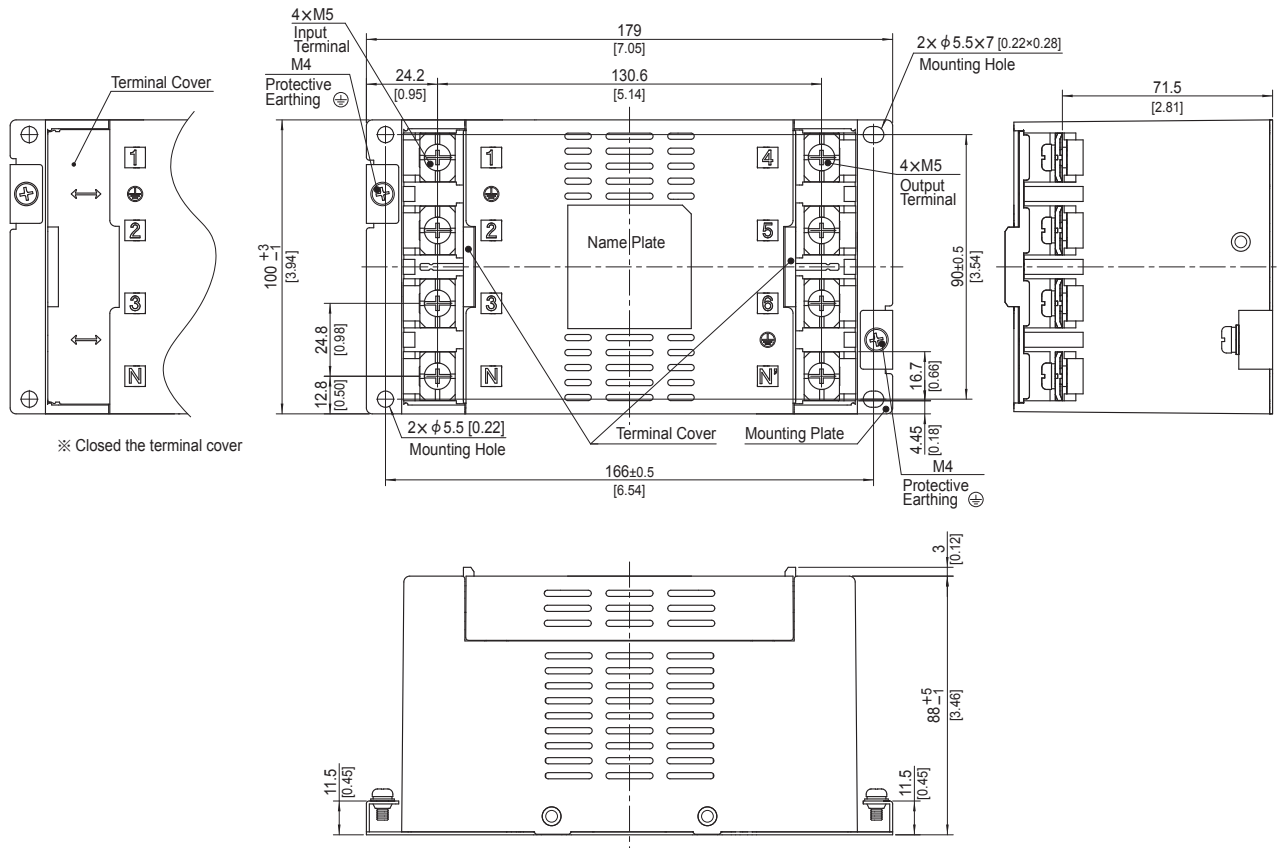

- ※ Dimensions in mm, [] = inches
- ※ Tolerance : ± 1 [± 0.04]
- ※ Weight : 1.7kg max
- ※ Mounting Plate : Galvanized Steel board t=1.0 [0.04]
- ※ Case Material : PBT
- ※ Terminal block screw tightening torque M5 : 3.0N · m max
- ※ Protective Earthing (PE) screw tightening torque M4 : 1.6N · m max
- ※ Can not be mounted upside-down. (mounted the top surface)
- ※ Keep free ventilation holes for cooling.

YAC series(120,160,200,300A)

YAC -120 -685

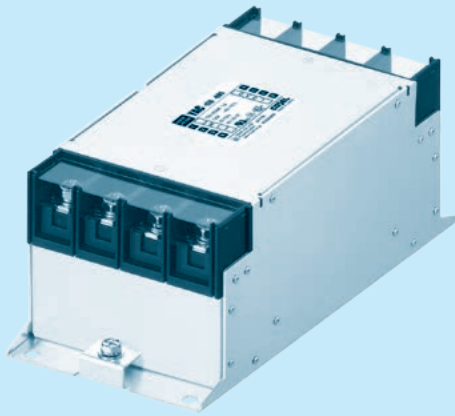

- ① Series Name
- ② Rated Current
- ③ Line to Ground Capacitor Code: See Table 1.1.

Table 1.1 Line to Ground Capacitor Code

Code	Leakage Current Y-Connection	Line to Ground Capacitor (nominal Value)	
		CY1	CY2
685	10.7mA typ *2 55mA max *3	6.8μF	Not provided
226 *1	41.5mA typ *2 220mA max *3	1.5μF	6.8μF×3

- *1 "226" is applied only to "300A" type.
- *2 At normal operation (Input 500V 50Hz) with applying 10V in between N (N') and FG (According to IEC60939).
- *3 At the worst case under normal operation (Input 500V 60Hz).

Features of YAC series

- Three-Phase Four-Wire System EMI/EMC Filter ideal for High-power office equipment and Energy storage systems
- Suitable for 150kHz-1MHz conduction noise reduction
- Product lineup that can flexibly respond to system and capacity changes in a compact/same body size

Specifications

No.	Items	YAC-120-685	YAC-160-685	YAC-200-685	YAC-300-685
1	Rated Voltage[VAC]	Three-Phase Four-Wire System Y-Connection 500/289 (Voltage Range:528/305 max) 50/60Hz *4			
2	Rated Current[A]	120	160	200	300
3	Test Voltage (Terminal-Mounting Plate)	2,800 VDC (Cutoff Current = 10mA), 1minute at room temperature and humidity			
4	Isolation Resistance (Terminal-Mounting Plate)	500 VDC 5MΩ min. at room temperature and humidity *5			
5	Leakage Current	Refer to table 1.1			
6	DC Resistance	4.5mΩ max	3.0mΩ max	2.5mΩ max	1.5mΩ max
7	Operating Temperature/Humidity	-40 to +85°C (Refer to Derating Curve)/20 to 95%RH (Non condensing)			
8	Storage Temperature/Humidity	-40 to +85°C/20 to 95%RH (Non condensing)			
9	Vibration	10 to 55Hz, 19.6m/s ² (2G), 3min. Period, 1hour each X, Y and Z axis			
10	Impact	196.1m/s ² (20G), 11ms Once each X, Y and Z axis			
11	Safety Agency Approvals	UL60939 [Overvoltage Category : III Altitude : 3000m] , CSA C22. 2 No. 8 (C-UL) EN60939 (DEMKO) [Overvoltage Category : III Altitude : 3000m] , ENEC			
12	Case Size (Without Projection)	157×140×340mm (W×H×D) [6.18×5.51×13.39 inches] (W×H×D)			
13	Weight	9.0kg max			5.5kg max

*4 Voltage indicates "Line Voltage/Phase Voltage".
*5 Only "YAC-300-226", Isolation Resistance specification is deleted.

Circuit Diagram

(1) Line to Ground Capacitor Code : 685

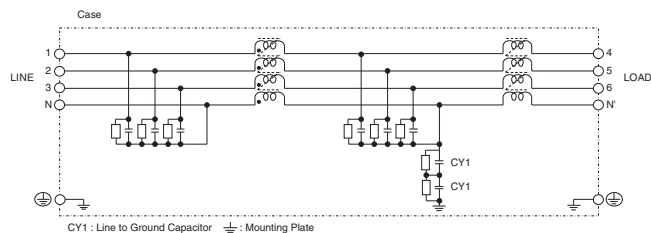

(2) Line to Ground Capacitor Code : 226

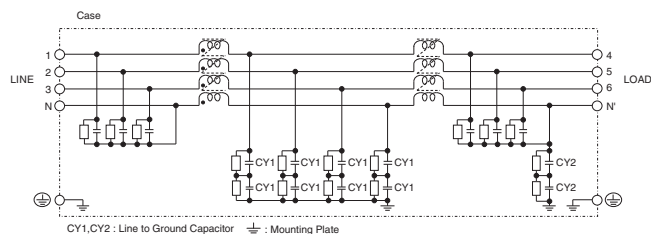

Derating Curve

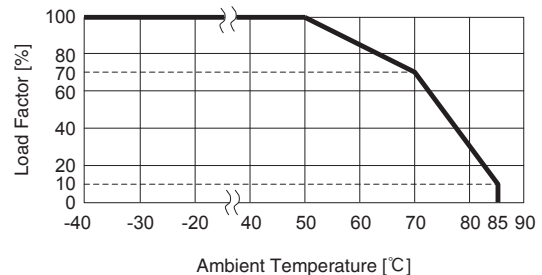

External view

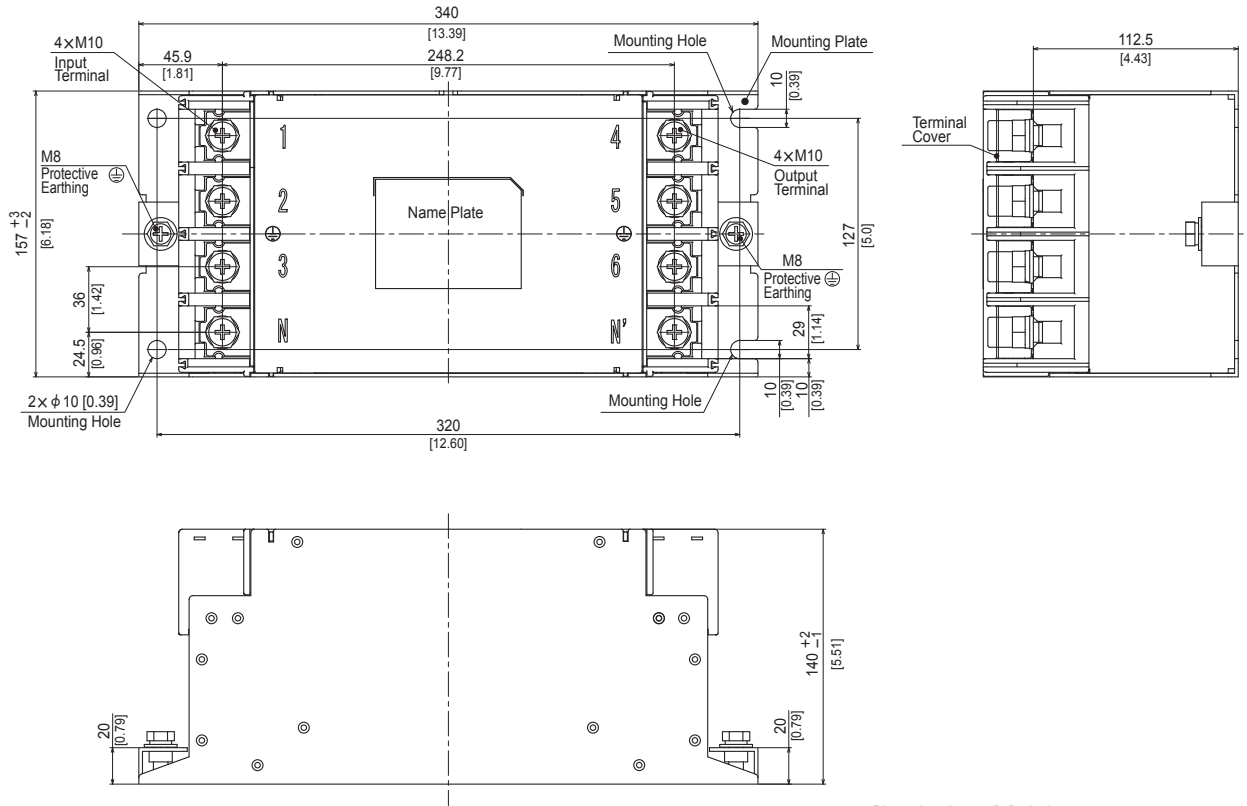

- ※ Dimensions in mm, [] = inches
- ※ Tolerance : ± 1 [± 0.04]
- ※ Weight : 9.0kg max (120A,160A,200A)
5.5kg max (300A)
- ※ Mounting Plate Material : Aluminum $t=2.0$ [0.08]
- ※ Terminal block screw tightening torque M10 : 14.2N · m max
- ※ Protective Earthing (PE) screw tightening torque M8 : 9.2N · m max
- ※ Can not be mounted upside-down. (mounted the top surface)

YAC-25-685

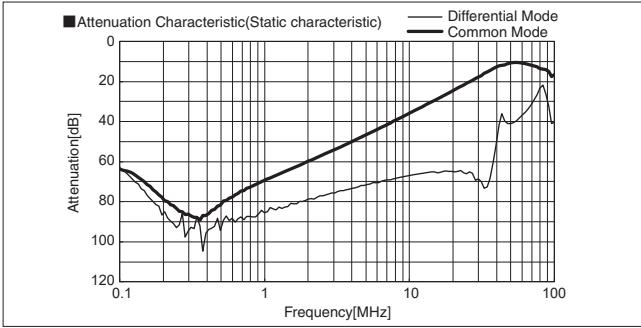

YAC-36-685

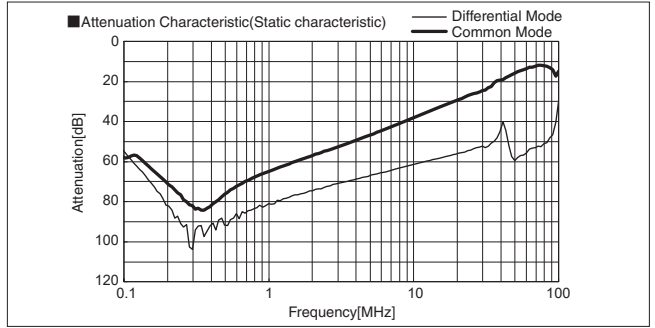

YAC-64-685

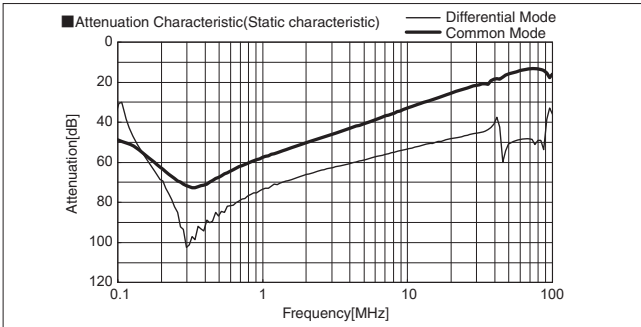

YAC-80-685

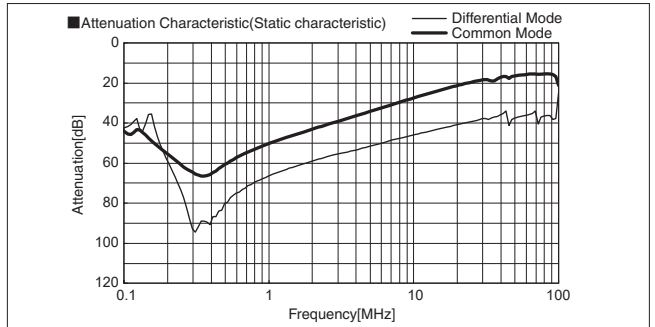

YAC-120-685

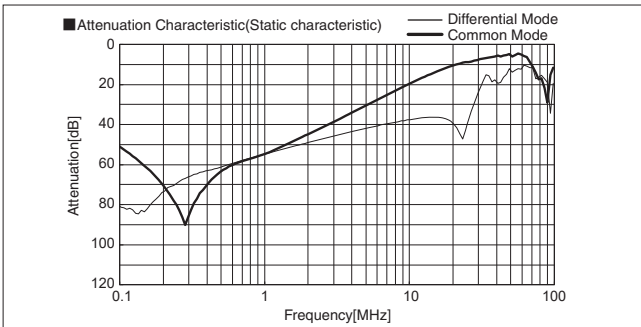

YAC-160-685

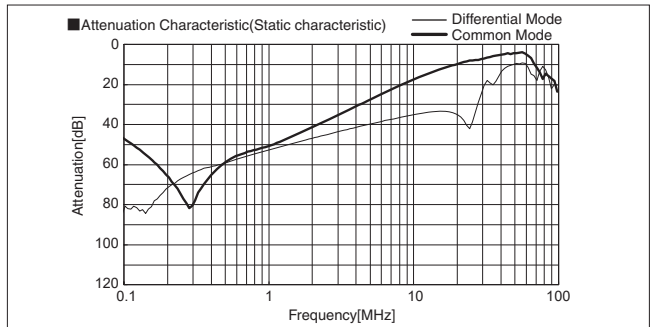

YAC-200-685

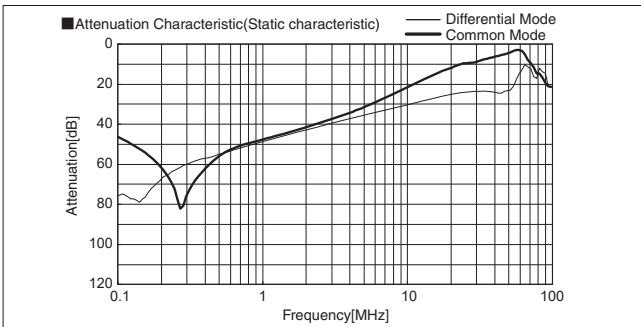

YAC-300-685

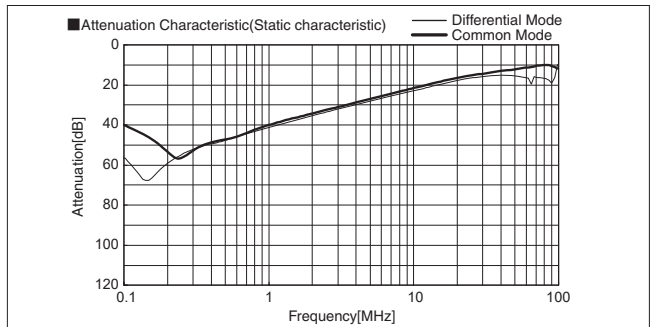

YAC-300-226

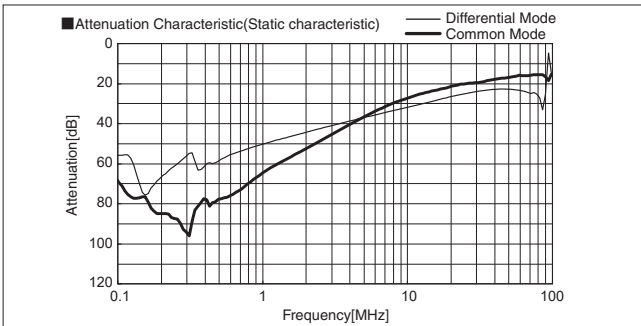

TBC series(50,60,80,100,150A)

TBC -50 -683

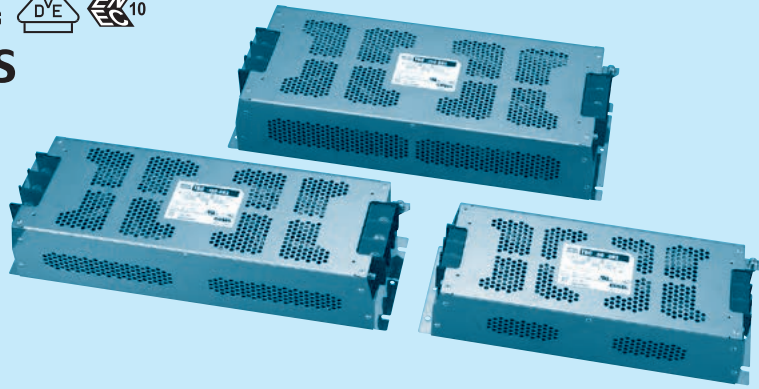

- ① Model Name
- ② Rated Current
- ③ Line to ground capacitor code: See table 1.1.

table 1.1 Line to ground capacitor code

Code	Leakage Current (Input 250/500V 60Hz)	Line to ground capacitor (nominal value)
223	1.0mA/2.0mA max	22,000pF
683	2.5mA/5.0mA max	68,000pF
104	3.5mA/7.0mA max	100,000pF

* When the line to ground capacitor code is different, the attenuation characteristic is different.

Features of TBC series

High-attenuation type of common mode noise from 150kHz to 1MHz (2-stage filter)

- Three phase rated voltage 500 VAC (voltage range:528V max)
- Selectable leakage current value

Specifications

No.	Items	TBC-50-683	TBC-60-683	TBC-80-683	TBC-100-683	TBC-150-683
1	Rated Voltage[V]	AC Three Phase 500 (voltage range:528 max) 50/60Hz				
2	Rated Current[A]	50	60	80	100	150
3	Test Voltage (Terminal-Mounting Plate)	2,500 VAC (Cutoff Current = 100mA), 1minute at room temperature and humidity				
4	Isolation Resistance (Terminal-Mounting Plate)	500 VDC 100MΩ min at room temperature and humidity				
5	Leakage current 250/500V 60Hz	2.5mA/5.0mA max				
6	DC resistance	14mΩ max	10mΩ max	10mΩ max	8mΩ max	6mΩ max
7	Safety agency approval temperatures	-25 to +85°C (Refer to Derating Curve)				
8	Operating temperature	-40 to +85°C (Refer to Derating Curve)				
9	Operating humidity	20 to 95%RH (Non condensing)				
10	Storage temperature/humidity	-40 to +85°C/20 to 95%RH (Non condensing)				
11	Vibration	10 to 55Hz, 19.6m/s ² (2G), 3min. Period, 1hour each X, Y and Z axis				
12	Impact	196.1m/s ² (20G), 11ms Once each X, Y and Z axis				
13	Safety agency approvals	UL1283, CSA C22.2 No.8 (C-UL), DIN EN60939 VDE0565 Teil3-1, ENEC				
14	Case size (without projection)	140×80×374 mm (W×H×D)		150×92×456 mm (W×H×D)		190×92×482 mm (W×H×D)
		[5.51×3.15×14.72 inches]		[5.91×3.62×17.95 inches]		[7.48×3.62×18.98 inches]
15	Weight	4.3kg max		7.7kg max		9.6kg max

Circuit Diagram

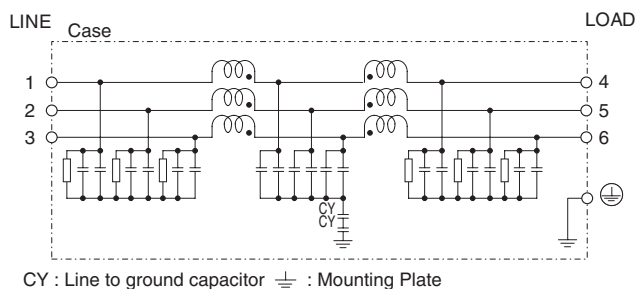

Derating Curve

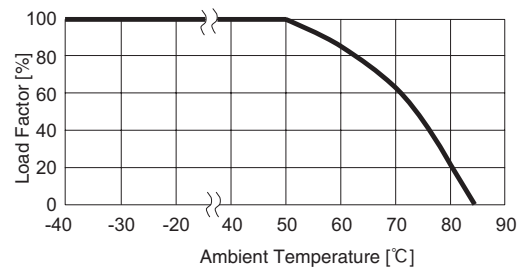

* Keep free ventilation holes for cooling.

External view

TBC-50-□□□ / TBC-60-□□□

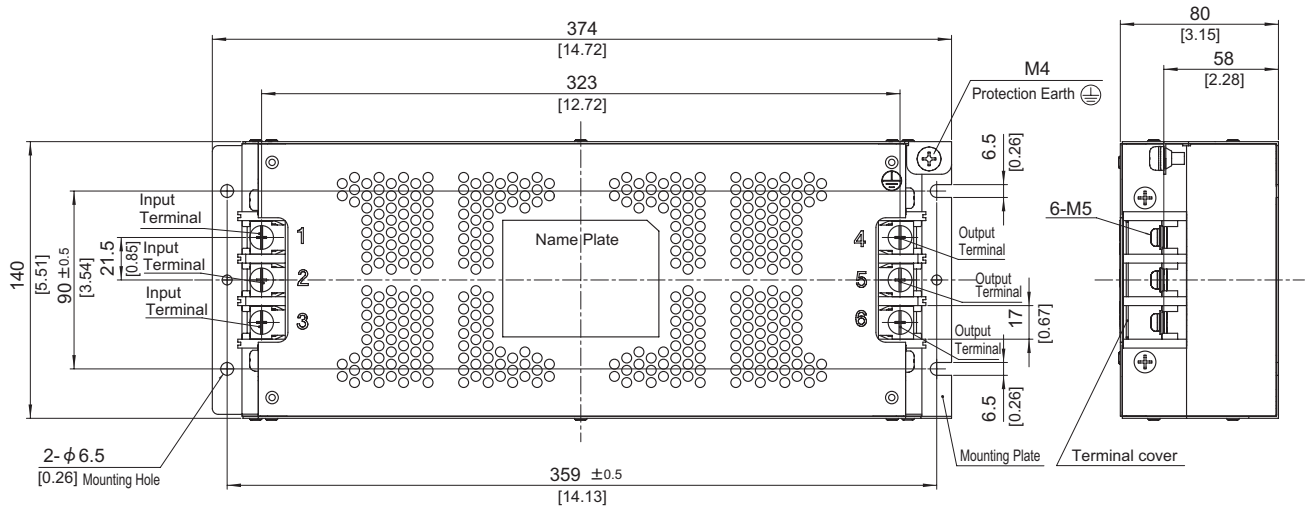

※ Can not be mounted upside-down.
(mounted the top surface)

- ※ Tolerance : ± 1 [± 0.04]
- ※ Weight : 4.3kg max
- ※ Chassis Material : Stainless steel $t=1.0$ [0.04]
- ※ Dimensions in mm, []=inches
- ※ Terminal block screw tightening torque M5:3.0N · m (30.7kgf · cm) max
- ※ Protection Earth screw tightening torque M4:1.6N · m (16.9kgf · cm) max

TBC-80-□□□ / TBC-100-□□□

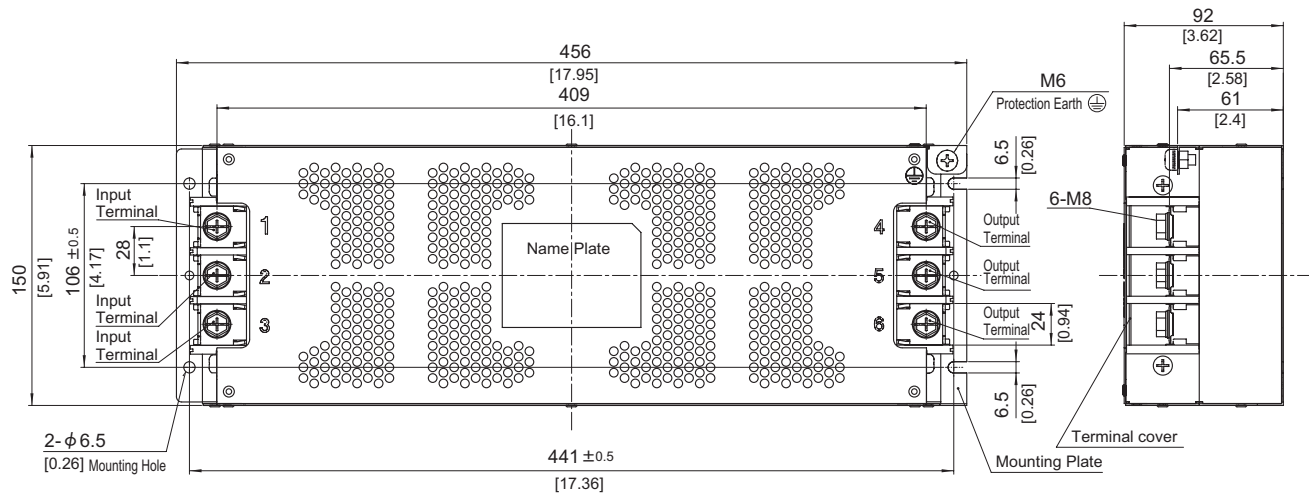

※ Can not be mounted upside-down.
(mounted the top surface)

- ※ Tolerance : ± 1 [± 0.04]
- ※ Weight : 7.7kg max
- ※ Chassis Material : Stainless steel $t=1.0$ [0.04]
- ※ Dimensions in mm, []=inches
- ※ Terminal block screw tightening torque M8:9.2N · m (93.9kgf · cm) max
- ※ Protection Earth screw tightening torque M6:5.8N · m (59.2kgf · cm) max

TBC-50-223

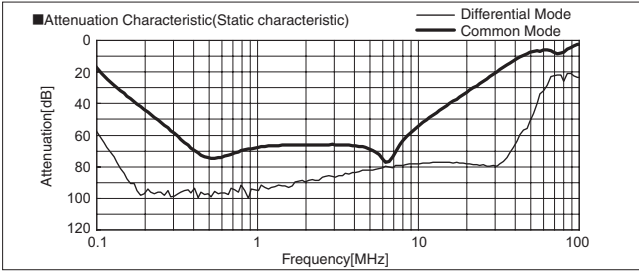

TBC-50-683

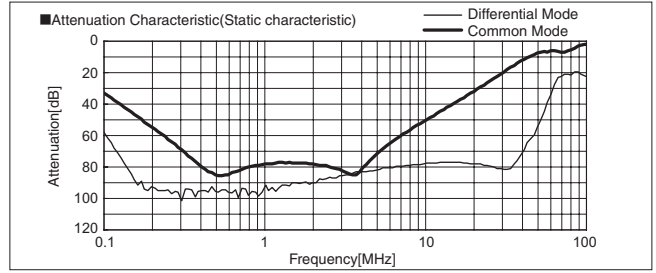

TBC-50-104

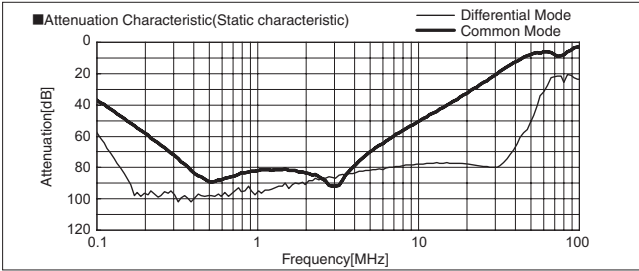

TBC-100-223

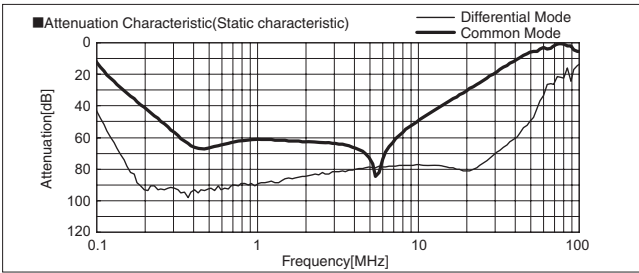

TBC-100-683

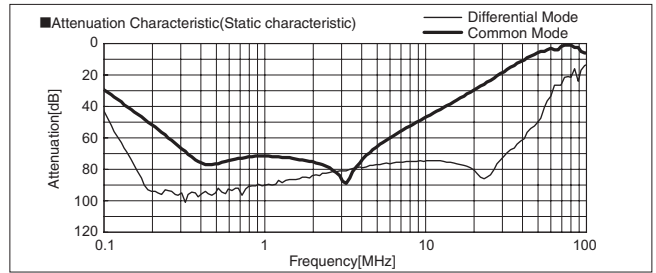

TBC-100-104

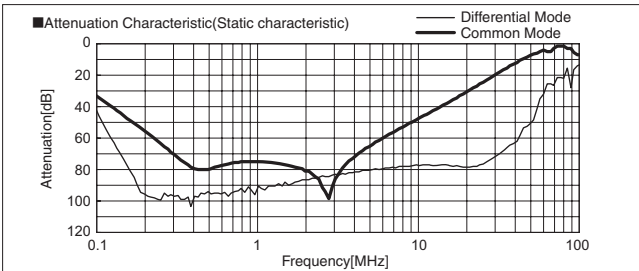

TBC-150-223

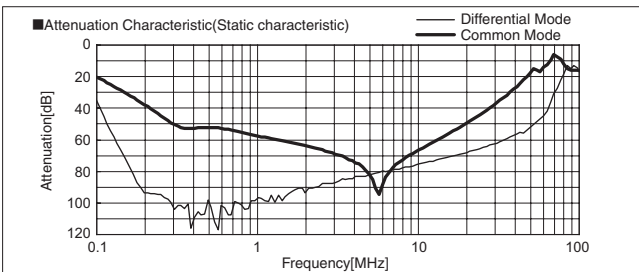

TBC-150-683

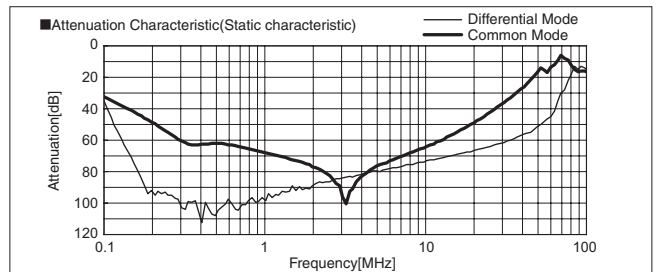

TBC-150-104

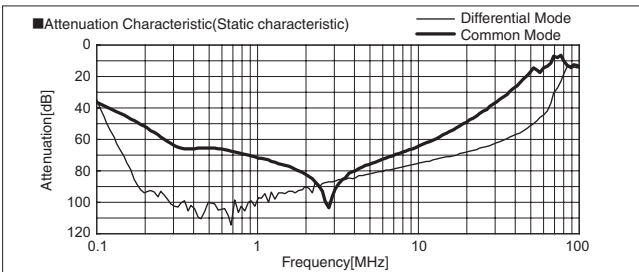

TBC series(200,250,300A)

TBC -200 -683

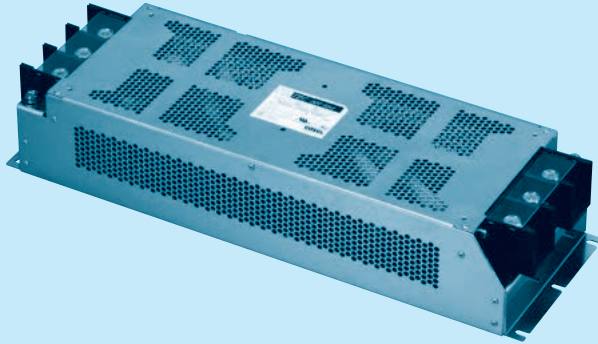

- ① Model Name
- ② Rated Current
- ③ Line to ground capacitor code: See table 1.1.

table 1.1 Line to ground capacitor code

Code	Leakage Current (Input 250/500V 60Hz)	Line to ground capacitor (nominal value)
223	1.0mA/2.0mA max	22,000pF
683	2.5mA/5.0mA max	68,000pF
104	3.5mA/7.0mA max	100,000pF

* When the line to ground capacitor code is different, the attenuation characteristic is different.

Features of TBC series

High-attenuation type of common mode noise from 150kHz to 1MHz (2-stage filter)

- Three phase rated voltage 500 VAC (voltage range:528V max)
- Selectable leakage current value

Specifications

No.	Items	TBC-200-683	TBC-250-683	TBC-300-683
1	Rated Voltage[V]	AC Three Phase 500 (voltage range:528 max) 50/60Hz		
2	Rated Current[A]	200	250	300
3	Test Voltage (Terminal-Mounting Plate)	2,500 VAC (Cutoff Current = 100mA), 1minute at room temperature and humidity		
4	Isolation Resistance (Terminal-Mounting Plate)	500 VDC 100MΩ min at room temperature and humidity		
5	Leakage current 250/500V 60Hz	2.5mA/5.0mA max		
6	DC resistance	4mΩ max	3mΩ max	2mΩ max
7	Safety agency approval temperatures	-25 to +85°C (Refer to Derating Curve)		
8	Operating temperature	-40 to +85°C (Refer to Derating Curve)		
9	Operating humidity	20 to 95%RH (Non condensing)		
10	Storage temperature/humidity	-40 to +85°C/20 to 95%RH (Non condensing)		
11	Vibration	10 to 55Hz, 19.6m/s ² (2G), 3min. Period, 1hour each X, Y and Z axis		
12	Impact	196.1m/s ² (20G), 11ms Once each X, Y and Z axis		
13	Safety agency approvals	UL1283, CSA C22.2 No.8 (C-UL) , DIN EN60939 VDE0565 Teil3-1, ENEC		
14	Case size (without projection)	190 X 110 X 580 mm [7.48 X 4.33 X 22.83 inches] (W X H X D)		
15	Weight	13.0kg max		

Circuit Diagram

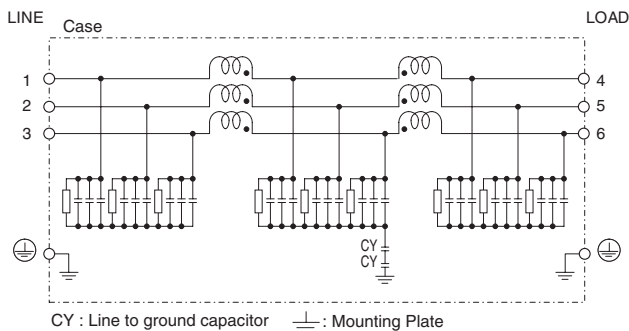

Derating Curve

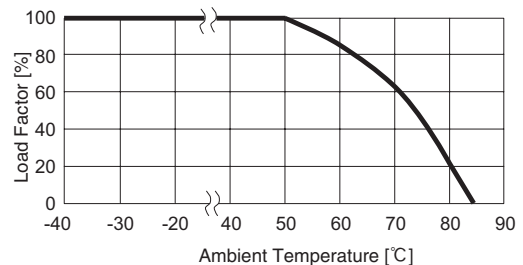

* Keep free ventilation holes for cooling.

External view

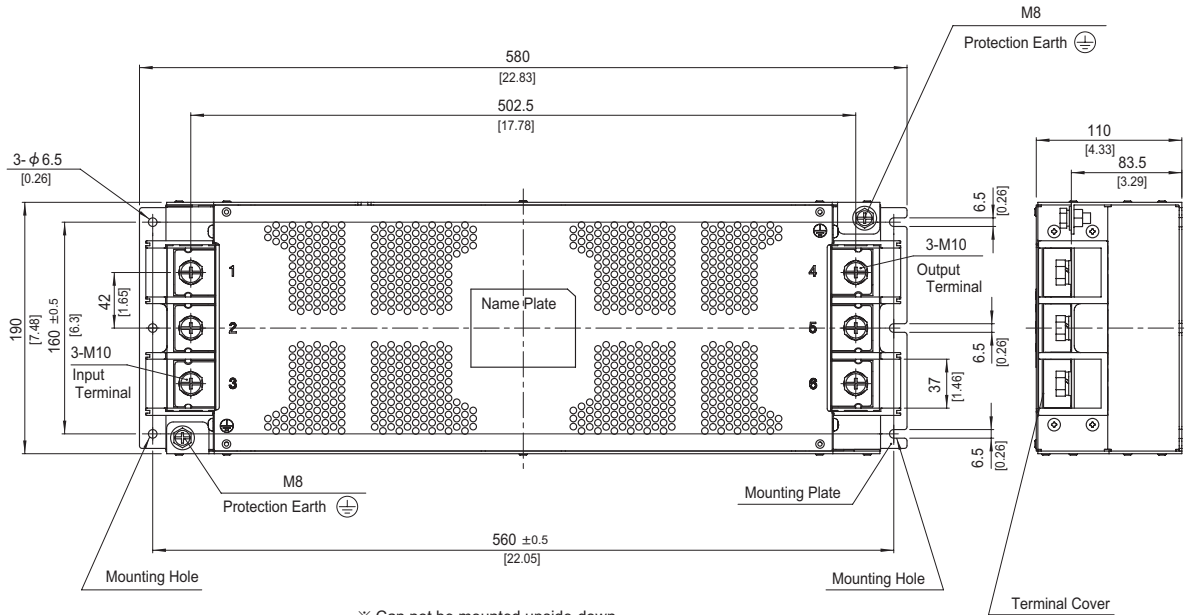

※ Can not be mounted upside-down.
(mounted the top surface)

- ※ Tolerance : ± 1 [± 0.04]
- ※ Weight : 13.0kg max
- ※ Mounting Plate : Stainless steel t=2.0 [0.08]
- ※ Dimensions in mm, []=inches
- ※ Terminal block screw tightening torque M10 : $14.2N \cdot m$ (144.9kgf · cm) max
- ※ Protection Earth screw tightening torque M8 : $9.2N \cdot m$ (93.9kgf · cm) max

TBC-200-223

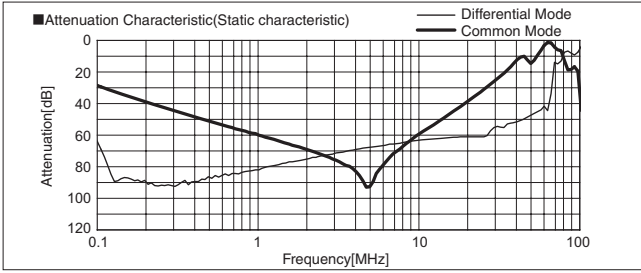

TBC-200-683

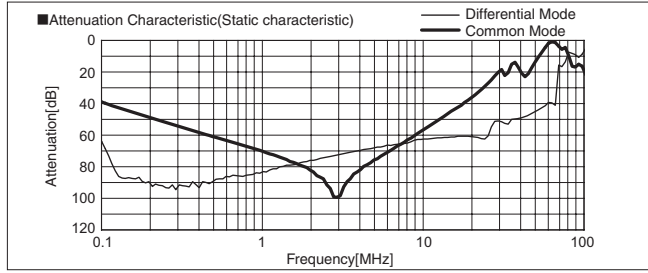

TBC-200-104

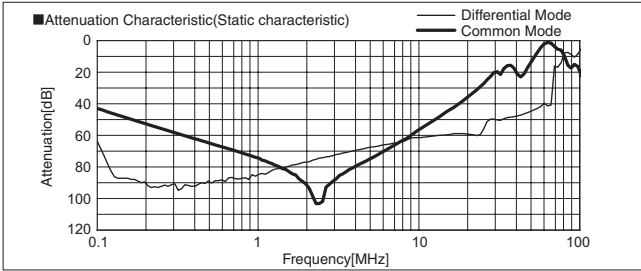

TBC-250-223

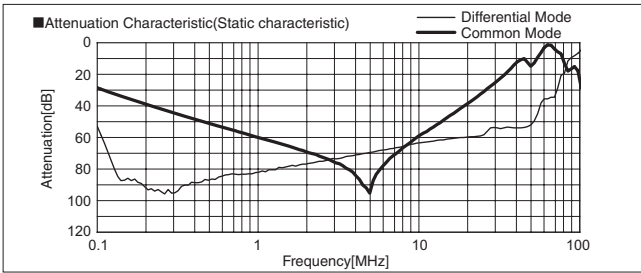

TBC-250-683

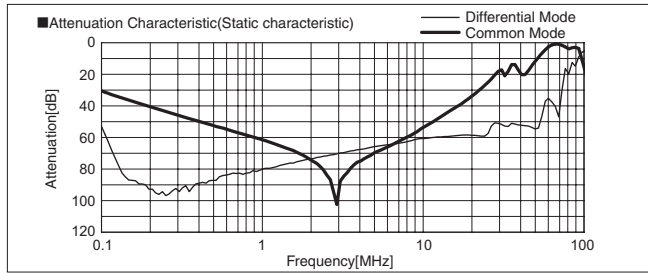

TBC-250-104

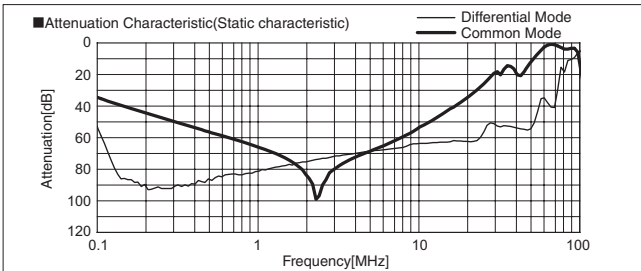

TBC-300-223

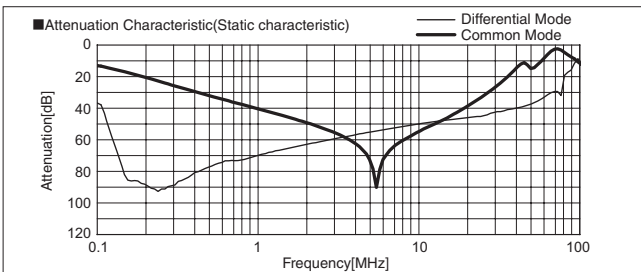

TBC-300-683

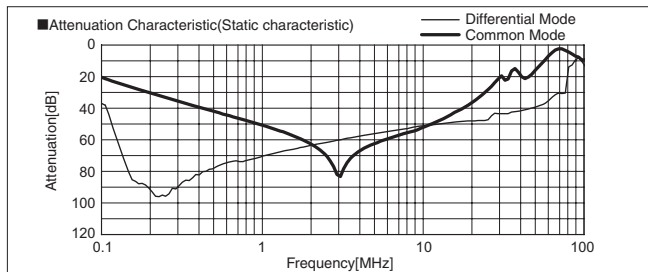

TBC-300-104

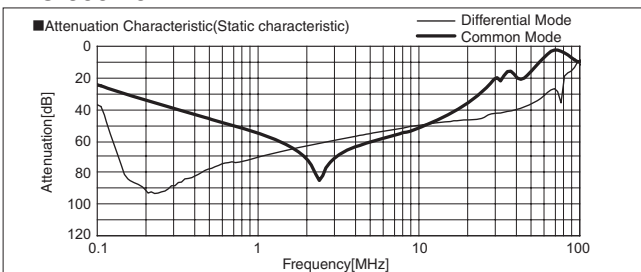

FTB series(80,100,150A)

FTB -80 -663 -□

① ② ③ ④

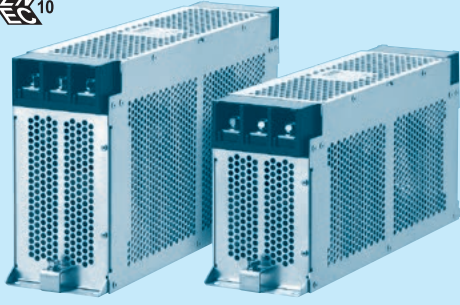

- ① Model Name
- ② Rated Current
- ③ Line to ground capacitor code: See table 1.1.

table 1.1 Line to ground capacitor code

Code	Leakage Current *2 Upper row : Δ-connection Lower row : Y-connection	Line to ground capacitor CY1 (nominal value)	Line to ground capacitor CY2 (nominal value)
203	1.0mA/2.0mA max 0.1mA/0.2mA max	10,000pF	10,000pF
663	2.5mA/5.0mA max 0.35mA/0.7mA max	33,000pF	33,000pF
324	12mA/24mA max 1.5mA/3.0mA max	220,000pF	100,000pF
355 *1	330mA/515mA max 40mA/80mA max	220,000pF	3,300,000pF

* When the line to ground capacitor code is different, the attenuation characteristic is different.

*1 "355" is applied only to "L" type.

*2 Input 250/500V 60Hz
(Only Δ-connection of "355" is 250/400V 60Hz)

- ④ Option
- H: Ultra high-attenuation type
"355" is not applied
- S: Hexagon socket head cap screw
(Standard type is Hexagon head screw)
- L: Ultra high-attenuation type for EU

Features of FTB series

Book type (Space-saving type)

- 2-stage filter High-attenuation (150kHz - 1MHz)
- Selectable leakage current value, Ultra high-attenuation type "-355-L" for EU (Y type with neutral earth system)

Specifications

No.	Items	FTB-80-663	FTB-100-663	FTB-150-663
1	Rated Voltage[V]	AC Three Phase 500 (voltage range: 528 max) 50/60Hz *3		
2	Rated Current[A]	80	100	150
3	Test Voltage (Terminal-Mounting Plate)	2,500 VAC (Cutoff Current = 100mA), 1minute at room temperature and humidity *4		
4	Isolation Resistance (Terminal-Mounting Plate)	500 VDC 100MΩ min at room temperature and humidity *5		
5	Leakage current 250/500V 60Hz	2.5mA/5.0mA max		
6	DC resistance	10mΩ max	8mΩ max	6mΩ max
7	Safety agency approval temperatures	-25 to +85°C (Refer to Derating Curve)		
8	Operating temperature	-40 to +85°C (Refer to Derating Curve)		
9	Operating humidity	20 to 95%RH (Non condensing)		
10	Storage temperature/humidity	-40 to +85°C/20 to 95%RH (Non condensing)		
11	Vibration	10 to 55Hz, 19.6m/s ² (2G), 3min. Period, 1hour each X, Y and Z axis		
12	Impact	196.1m/s ² (20G), 11ms Once each X, Y and Z axis		
13	Safety agency approvals	UL1283, CSA C22.2 No.8 (C-UL), DIN EN60939 VDE0565 Teil3-1, ENEC		
14	Case size (without projection)	100 X 170 X 350 mm (W X H X D) [3.94 X 6.69 X 13.78 inches]	100 X 210 X 400 mm (W X H X D) [3.94 X 8.27 X 15.75 inches]	
15	Weight	5.3kg max		7.8kg max

*3 Only capacitor code "355", Three Phase Δ-connection : 400 (440 max), Y-connection : 500 (528 max)

*4 Only capacitor code "324","355" 2,800 VDC (Cutoff Current = 10mA), 1minute at room temperature and humidity.

*5 Only capacitor code "355", Isolation resistance specification is deleted.

Circuit Diagram

(1) Line to ground capacitor code : 203, 663, 324

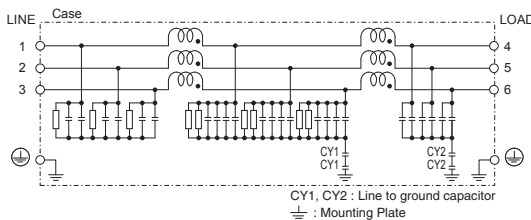

(2) FTB-□□-355-L

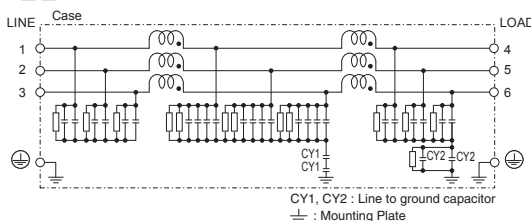

Derating Curve

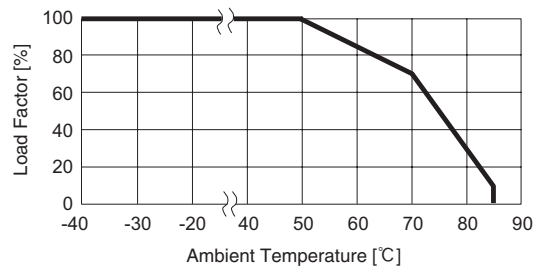

* Keep free ventilation holes for cooling.

External view

FTB-80-□□□ / FTB-100-□□□

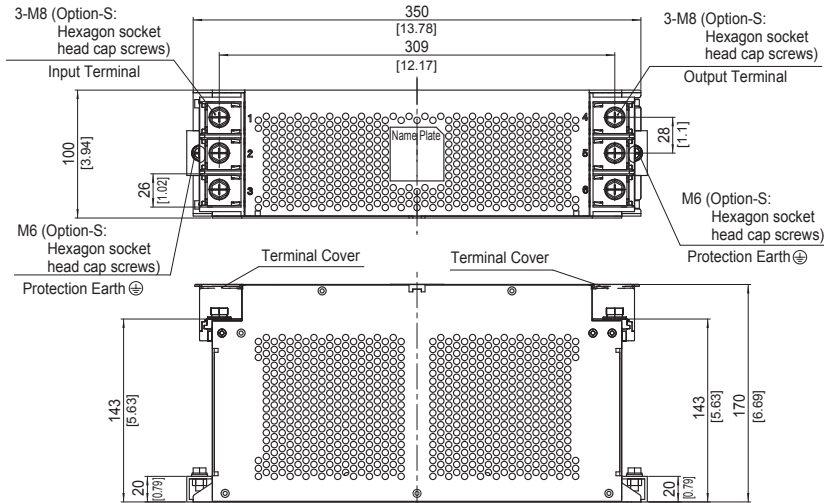

※ The air hole for heat radiation is not on the opposite side side.

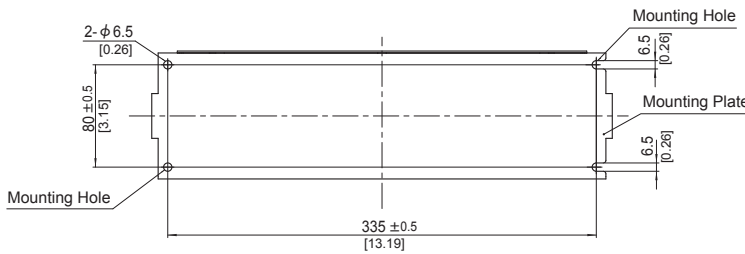

- ※ Tolerance : ± 1 [± 0.04]
- ※ Weight : 5.3kg max
- ※ Mounting Plate : Aluminum $t = 2.0$ [0.08]
- ※ Dimensions in mm, []=inches
- ※ Terminal block screw tightening torque
M8 : 9.2N · m(93.9kgf · cm)max
- ※ Protection Earth (PE) screw tightening torque
M6 : 5.8N · m(59.2kgf · cm)max
- ※ Can not be mounted upside-down
(mounted the top surface)
- ※ Keep free ventilation holes for cooling

FTB-150-□□□

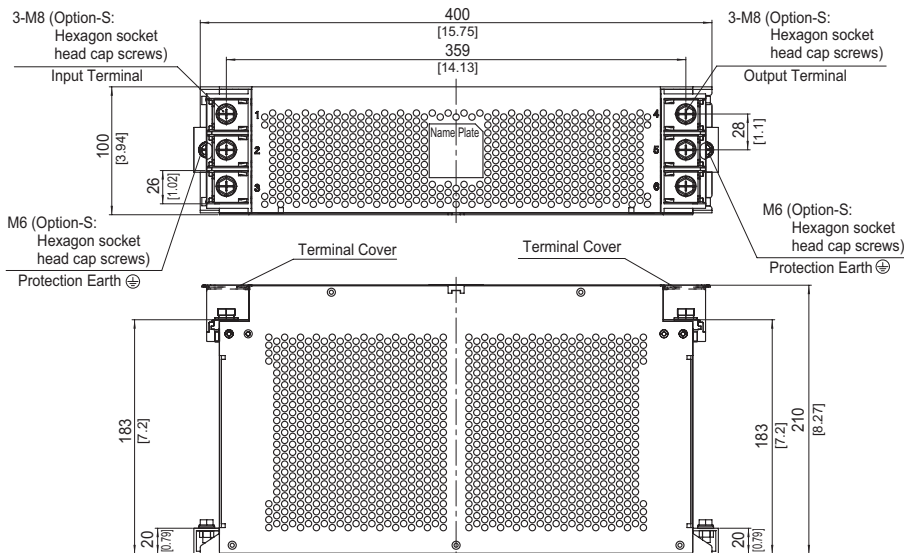

※ The air hole for heat radiation is not on the opposite side side.

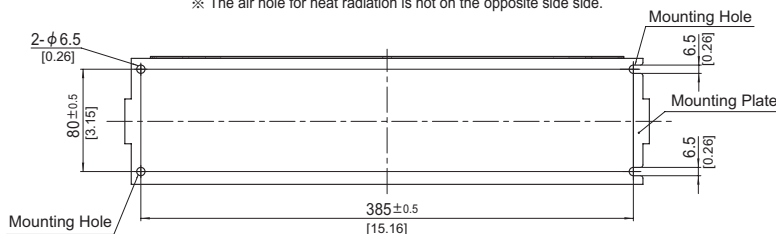

- ※ Tolerance : ± 1 [± 0.04]
- ※ Weight : 7.8kg max
- ※ Mounting Plate : Aluminum $t = 2.0$ [0.08]
- ※ Dimensions in mm, []=inches
- ※ Terminal block screw tightening torque
M8 : 9.2N · m(93.9kgf · cm)max
- ※ Protection Earth (PE) screw tightening torque
M6 : 5.8N · m(59.2kgf · cm)max
- ※ Can not be mounted upside-down
(mounted the top surface)
- ※ Keep free ventilation holes for cooling

FTB-80-203

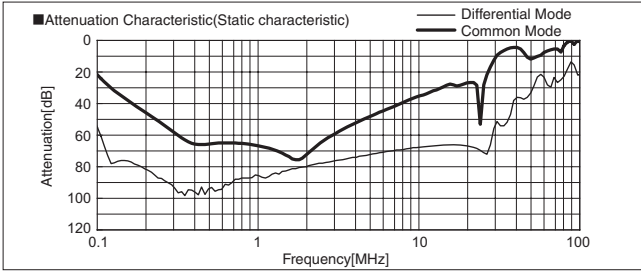

FTB-80-663

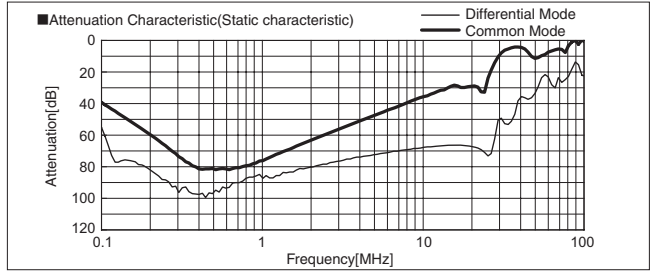

FTB-80-324

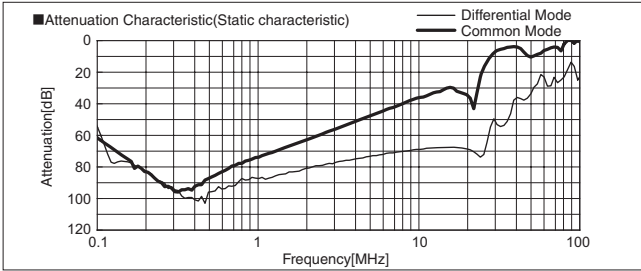

FTB-100-203

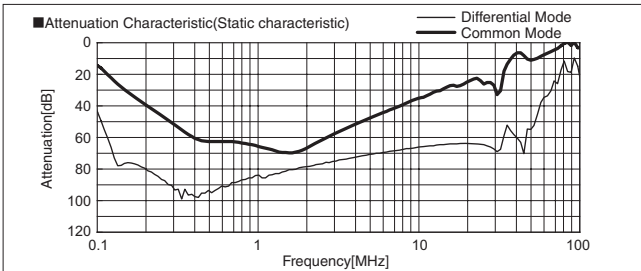

FTB-100-663

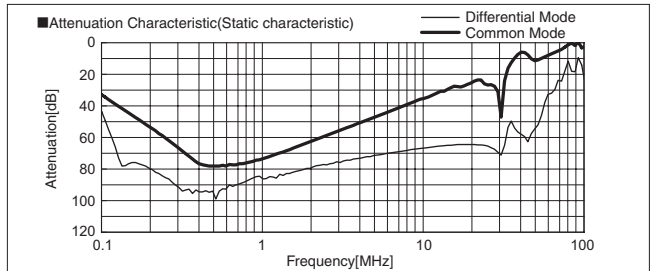

FTB-100-324

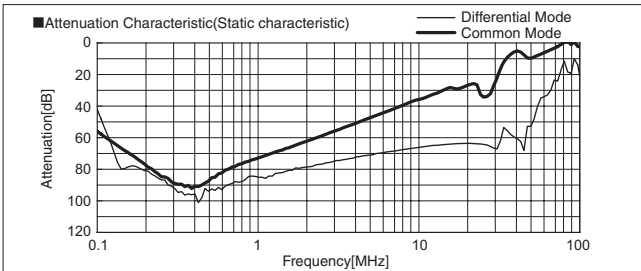

FTB-150-203

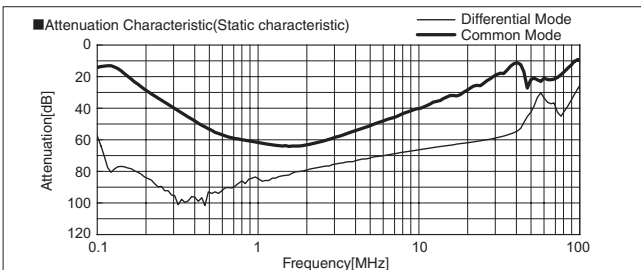

FTB-150-663

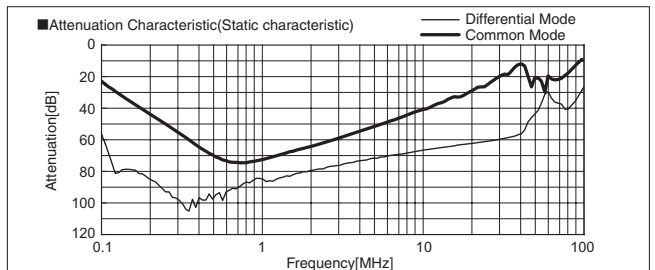

FTB-150-324

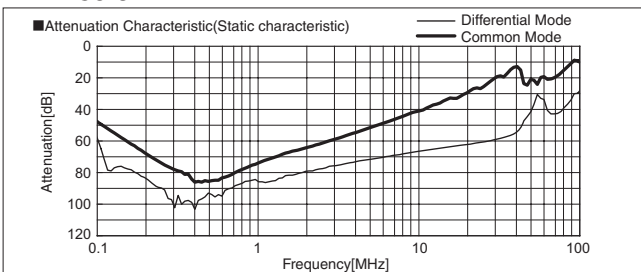

FTB-80-203-H

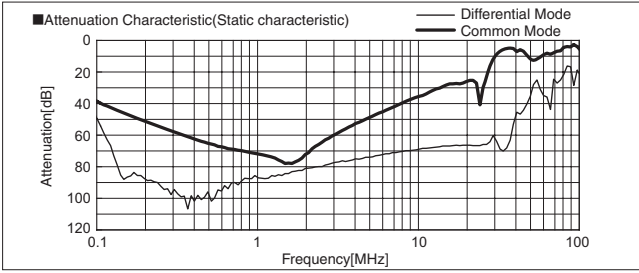

FTB-80-663-H

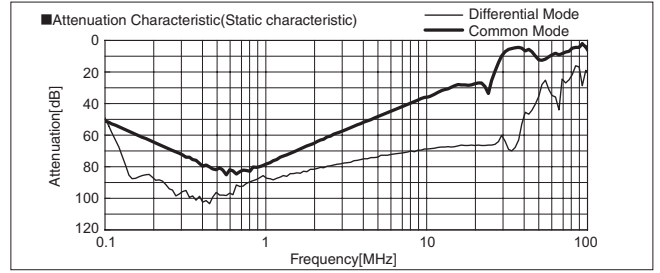

FTB-80-324-H

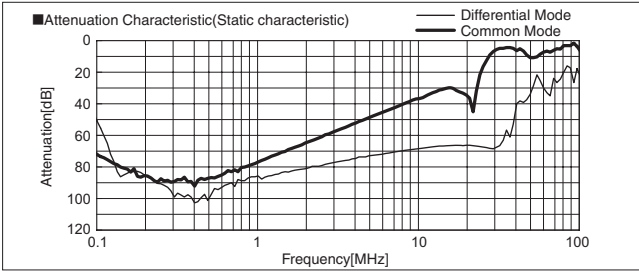

FTB-100-203-H

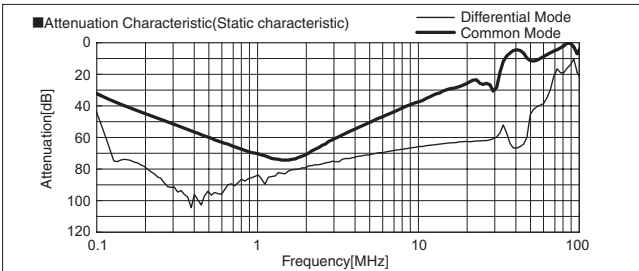

FTB-100-663-H

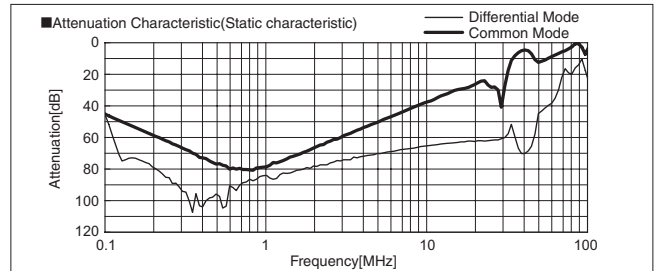

FTB-100-324-H

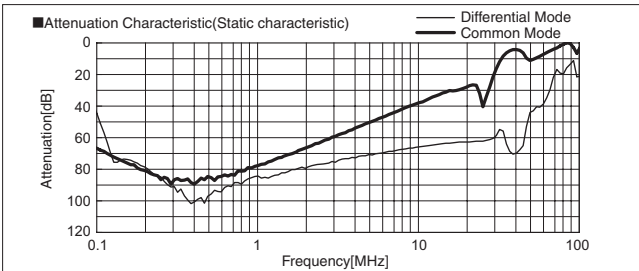

FTB-150-203-H

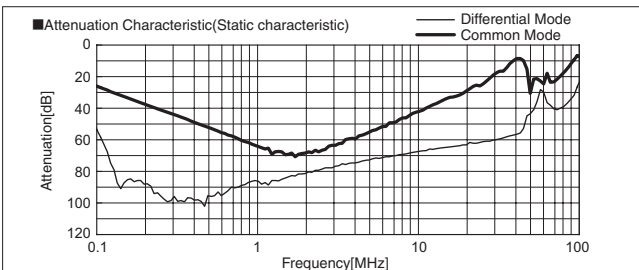

FTB-150-663-H

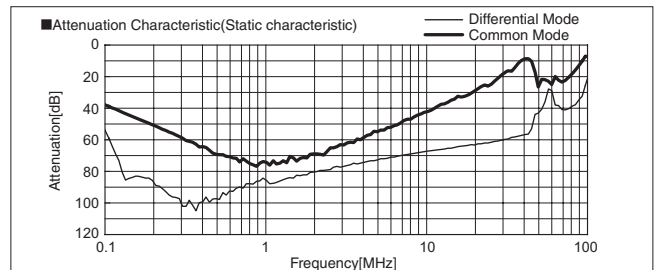

FTB-150-324-H

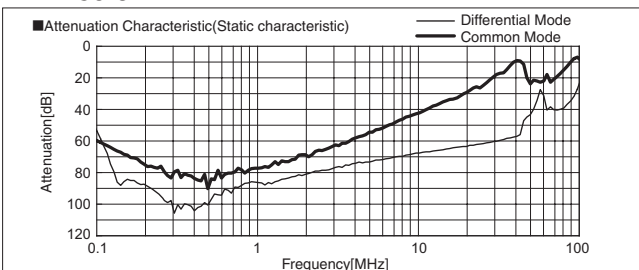

FTB-80-203-L

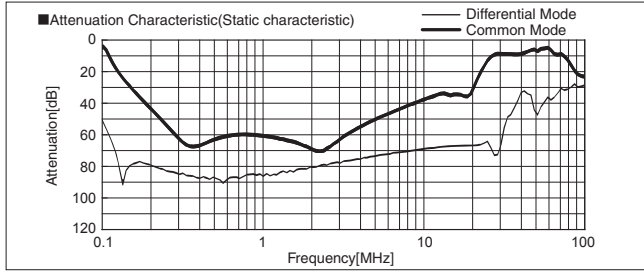

FTB-80-663-L

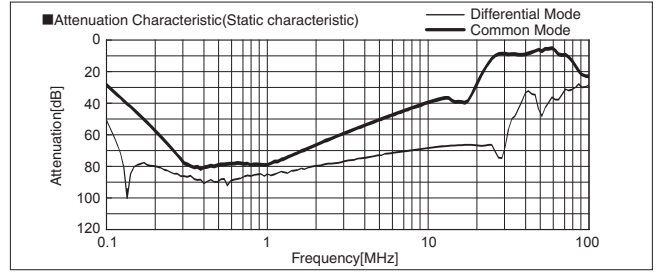

FTB-80-324-L

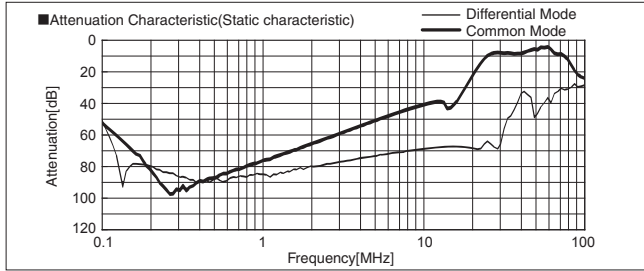

FTB-80-355-L

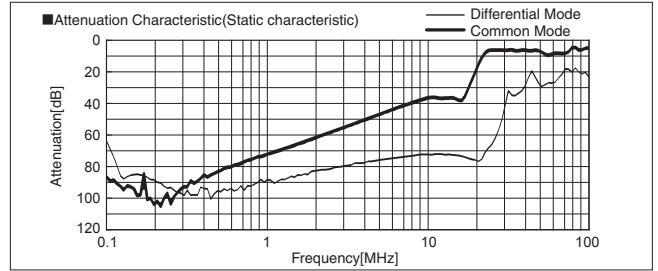

FTB-100-203-L

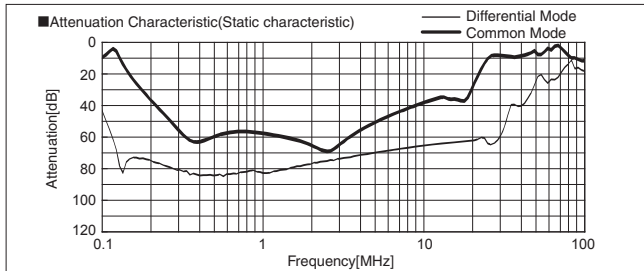

FTB-100-663-L

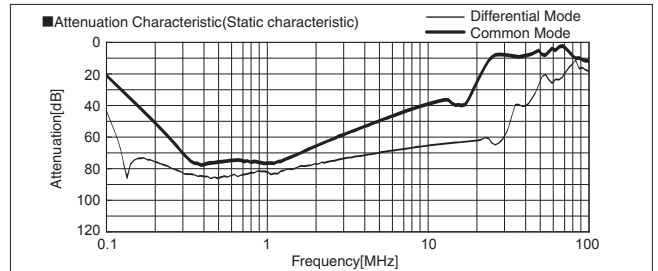

FTB-100-324-L

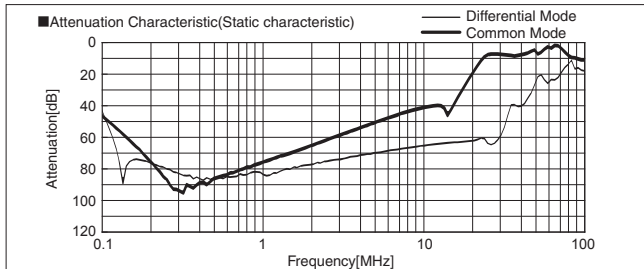

FTB-100-355-L

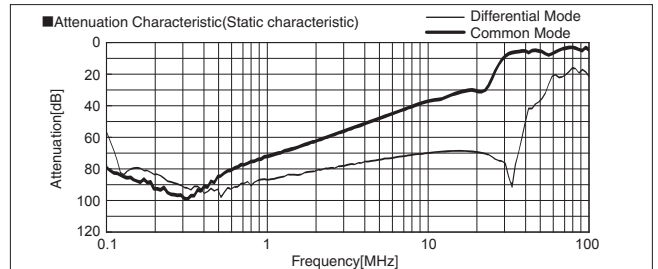

FTB-150-203-L

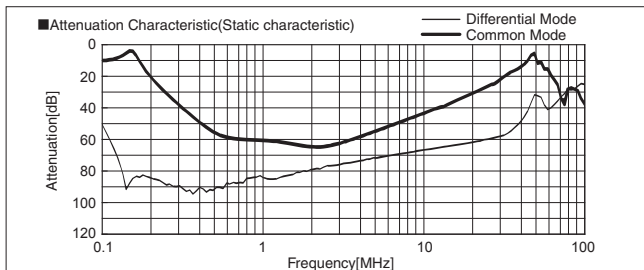

FTB-150-663-L

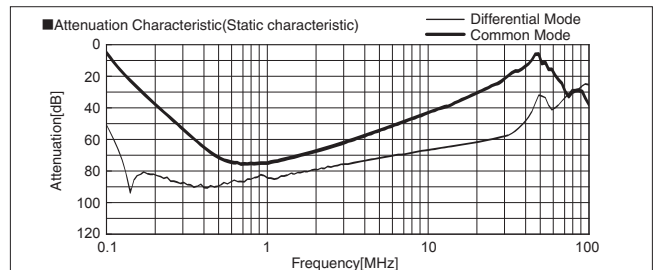

FTB-150-324-L

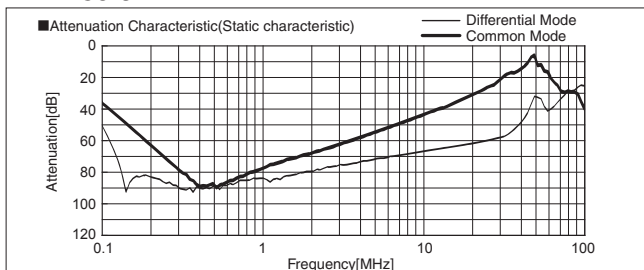

FTB-150-355-L

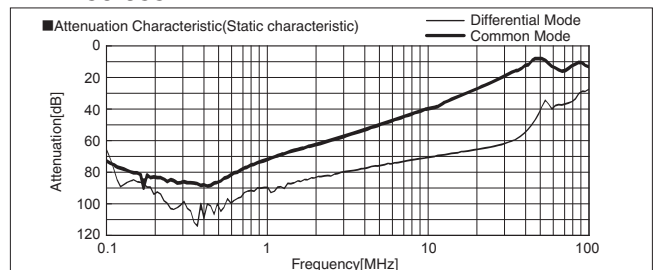

FSB series(10,20,30A)

FSB -30 -324 -□

① ② ③ ④



The terminal cover is retracted inside the unit

Features of FSB series

EMI/EMC Filter for motor drive system (AC servo)

- Improve saturation resistance (There is such as performance improvement type “-254-HU”)
- Book type (Space-saving type)
- Quick and easy push-down terminal
Just connect the wires, push-down and tighten the screws with a screwdriver

Specifications

No.	Items	FSB-10-324	FSB-20-324	FSB-30-324
1	Rated Voltage[V]	AC Three Phase 500 (voltage range:528 max) 50/60Hz *3 *4		
2	Rated Current[A]	10	20	30
3	Test Voltage (Terminal-Mounting Plate)	2,800 VDC (Cutoff Current = 10mA), 1minute at room temperature and humidity *5		
4	Isolation Resistance (Terminal-Mounting Plate)	500 VDC 100MΩ min at room temperature and humidity *6		
5	Leakage current 250/500V 60Hz	12mA/24mA max		
6	DC resistance	100mΩ max	38mΩ max	20mΩ max
7	Safety agency approval temperatures	-25 to +85°C (Refer to Derating Curve)		
8	Operating temperature	-40 to +85°C (Refer to Derating Curve)		
9	Operating humidity	20 to 95%RH (Non condensing)		
10	Storage temperature/humidity	-40 to +85°C/20 to 95%RH (Non condensing)		
11	Vibration	10 to 55Hz, 19.6m/s ² (2G), 3min. Period, 1hour each X, Y and Z axis		
12	Impact	196.1m/s ² (20G), 11ms Once each X, Y and Z axis		
13	Safety agency approvals	UL1283, CSA C22.2 No.8 (C-UL), DIN EN60939 VDE0565 Teil 3-1, ENEC		
14	Case size (without projection)	66 X 100 X 240 mm (W X H X D) [2.60 X 3.94 X 9.45 inches] (W X H X D)		
15	Weight	1.8kg max		

*3 Only capacitor code “355”, Three Phase Δ-connection : 400 (440 max), Y-connection : 500 (528 max)
 *4 Only “FSB-□□□□□□□□-U”, Three Phase 250 (275 max)
 *5 Only capacitor code “203”, “573”, “693”, “104”, 2,500VAC (Cutoff Current = 100mA), 1minute at room temperature and humidity.
 *6 Only capacitor code “335”, “355”, Isolation resistance specification is deleted.

- ① Model Name
- ② Rated Current
- ③ Line to ground capacitor code: See table 1.1.

table1.1 Line to ground capacitor code

Code	Leakage Current *1 Upper row : Δ-connection Lower row : Y-connection	Line to ground capacitor CY1 (nominal value)	Line to ground capacitor CY2 (nominal value)
203	1.0mA/2.0mA max 0.1mA/0.2mA max	0.01 μF	0.01 μF
573 *2	2.5mA max/Not applicable 0.35mA max/Not applicable	0.01 μF	0.047 μF
693	2.5mA/5.0mA max 0.35mA/0.7mA max	0.022 μF	0.047 μF
104	3.5mA/7.0mA max 0.5mA/1.0mA max	0.033 μF	0.068 μF
254 *2	12mA max/Not applicable 1.5mA max/Not applicable	0.033 μF	0.22 μF
324	12mA/24mA max 1.5mA/3.0mA max	0.1 μF	0.22 μF
335 *2	160mA max/Not applicable 20mA max/Not applicable	0.033 μF	3.3 μF
355	180mA/270mA max 25mA/50mA max	0.22 μF	3.3 μF

- * When the line to ground capacitor code is different, the attenuation characteristic is different.
- *1 Input 250/500V 60Hz (Only Δ-connection of “355” is 250/400V 60Hz)
- *2 Only “U” type is applied.
- ④ Option
 H : Ultra high-attenuation type
 U : Improve differential mode attenuation (Rated voltage 250V)
 Only “573”, “254”, “335” is applied.

Circuit Diagram

(1) Line to ground capacitor code : 203, 693, 104, 324

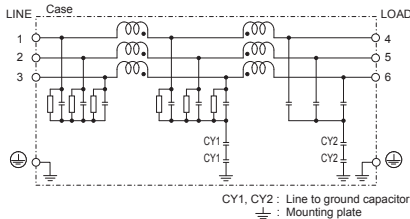

(2) Line to ground capacitor code : 355

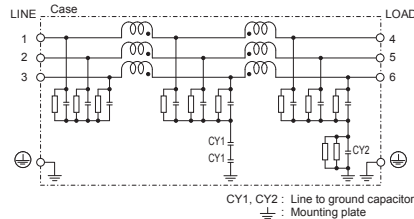

(3) Line to ground capacitor code : 573, 254
Option : U

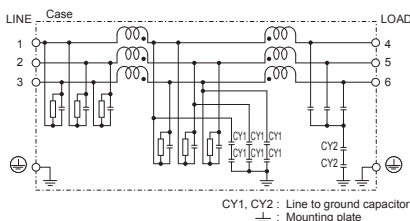

(4) Line to ground capacitor code : 335
Option : U

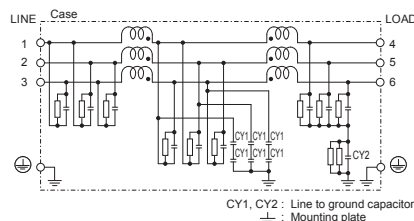

Derating Curve

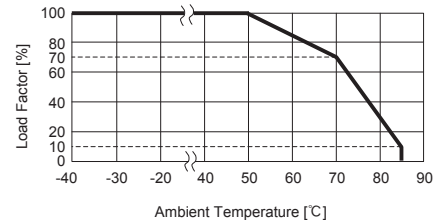

* Keep free ventilation holes for cooling.

External view

This product is shipped in the following condition, because it is equipped with push-down terminals.

- ① The terminal cover is retracted inside the unit.
- ② The screws for connecting the terminals are held in the up right position.

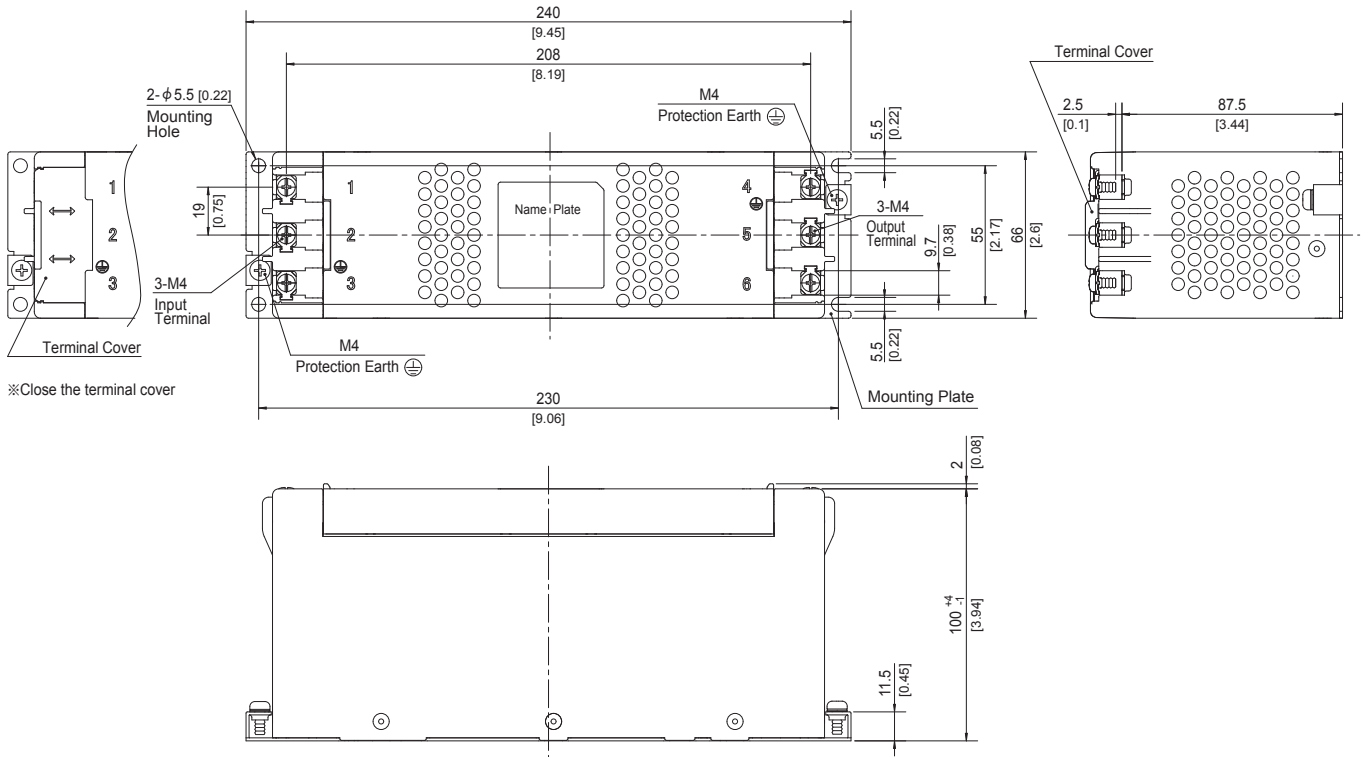

※Close the terminal cover

- ※ Tolerance : ± 1 [± 0.04]
- ※ Weight : 1.8kg max
- ※ Mounting Plate : Hot-dip Galvanized Steel board $t=1.2$ [0.05]
- ※ Case : PBT
- ※ Dimensions in mm, []=inches
- ※ Terminal block screw tightening torque M4 : $1.6N \cdot m$ (16.9kgf·cm)max
- ※ Can not be mounted upside-down (mounted the top surface)
- ※ Keep free ventilation holes for cooling

FSB-10-693

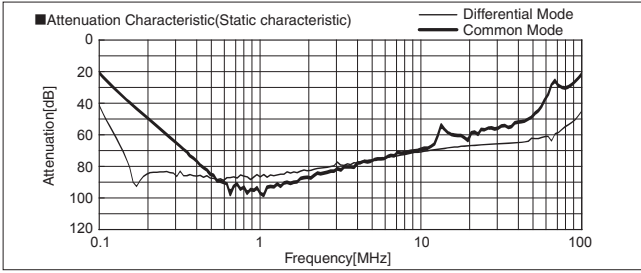

FSB-10-104

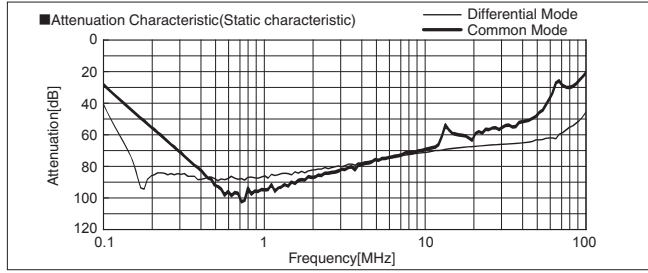

FSB-10-324

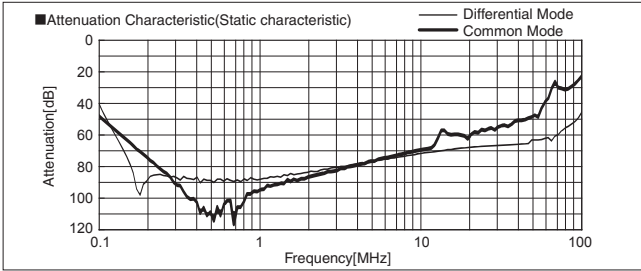

FSB-10-355

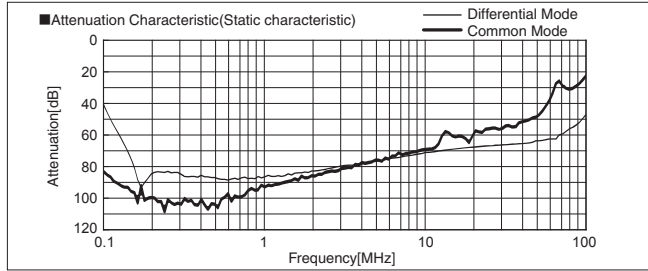

FSB-20-693

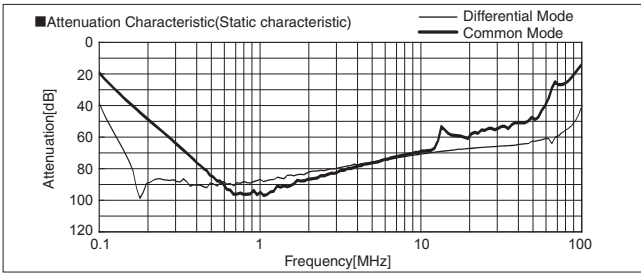

FSB-20-104

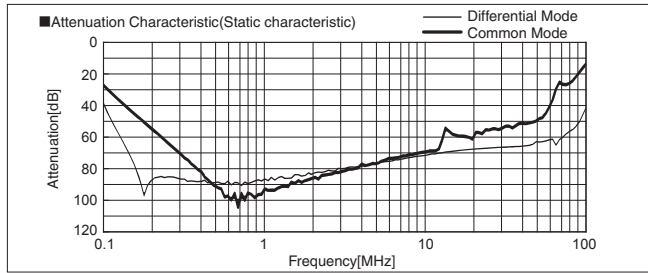

FSB-20-324

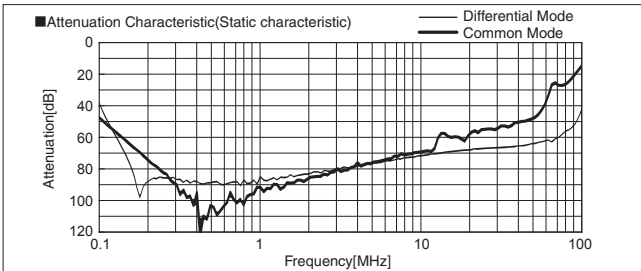

FSB-20-355

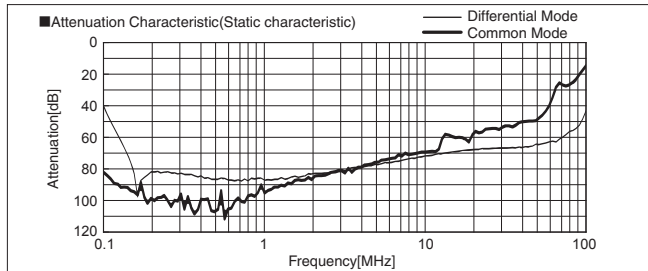

FSB-30-693

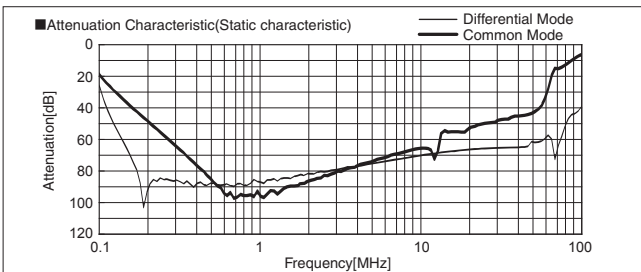

FSB-30-104

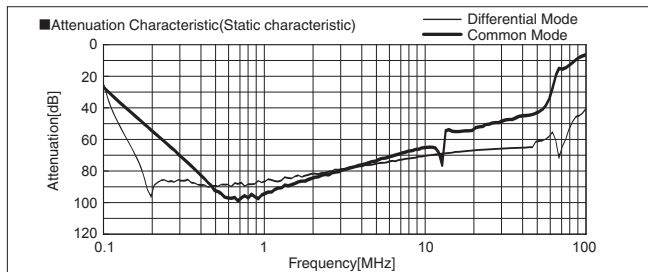

FSB-30-324

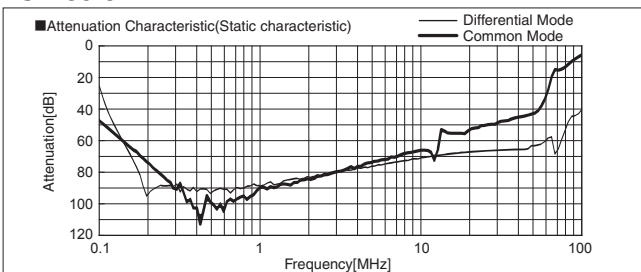

FSB-30-355

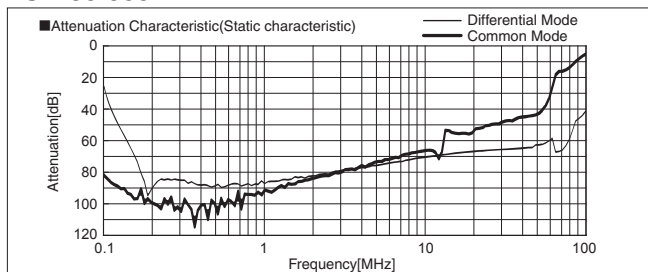

FSB-10-693-H

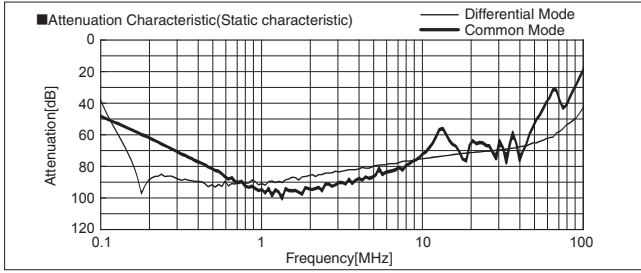

FSB-10-104-H

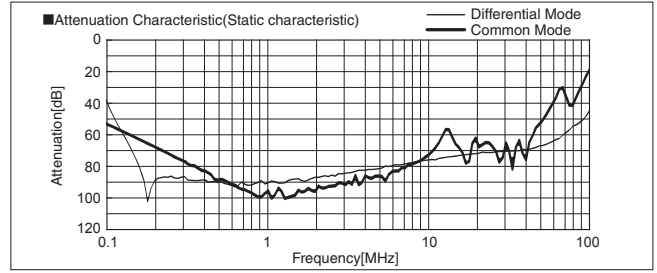

FSB-10-324-H

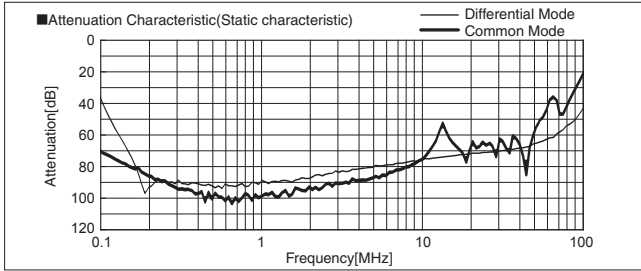

FSB-10-355-H

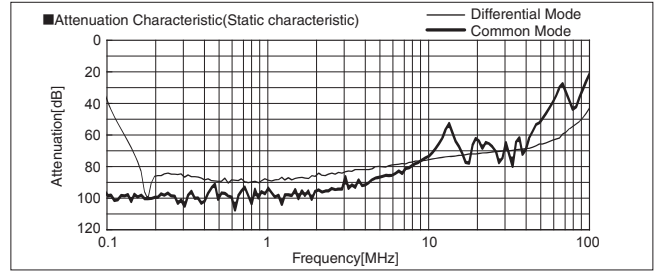

FSB-20-693-H

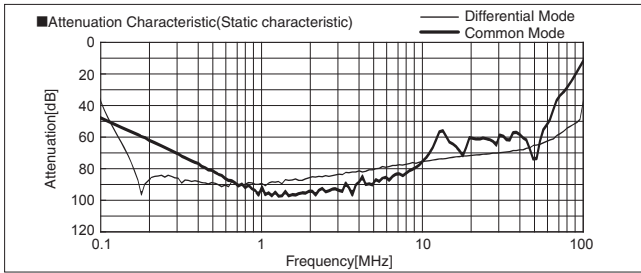

FSB-20-104-H

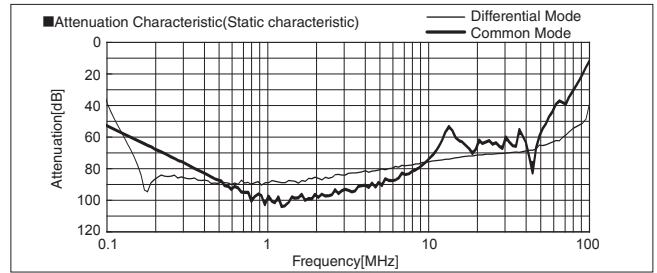

FSB-20-324-H

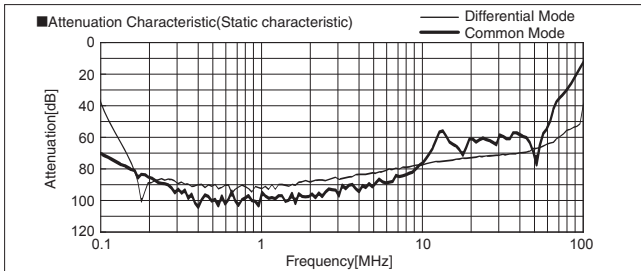

FSB-20-355-H

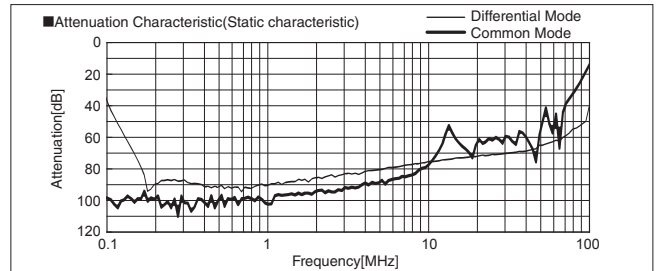

FSB-30-693-H

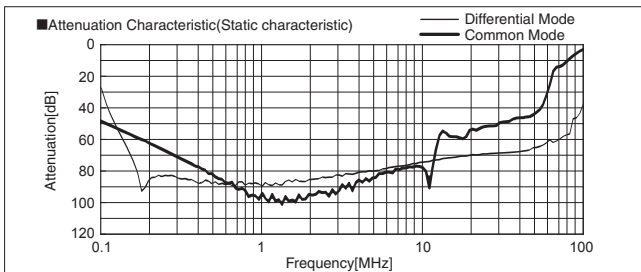

FSB-30-104-H

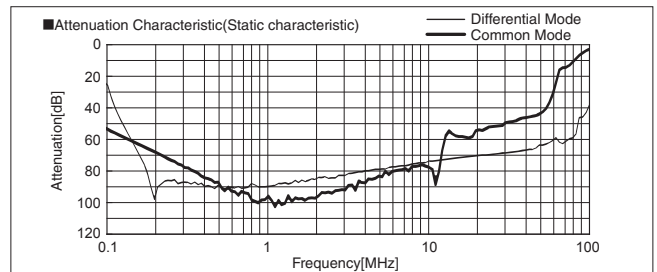

FSB-30-324-H

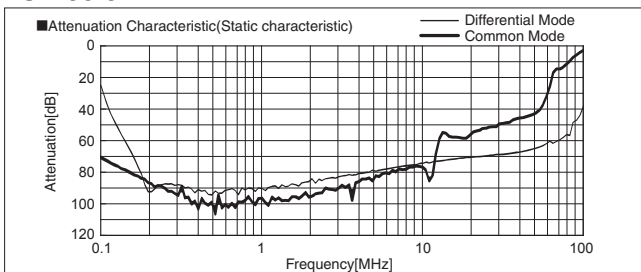

FSB-30-355-H

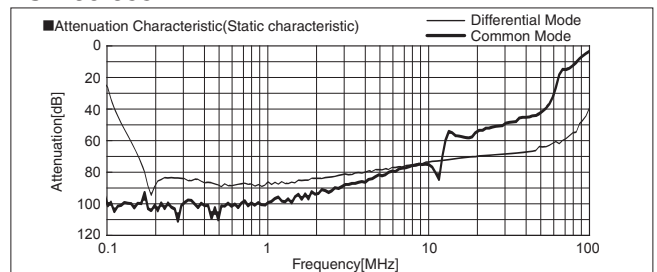

FSB-10-573-U

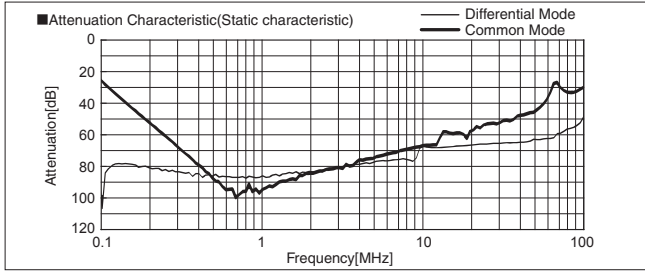

FSB-10-254-U

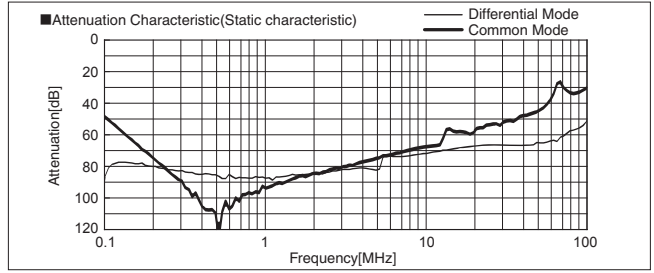

FSB-10-335-U

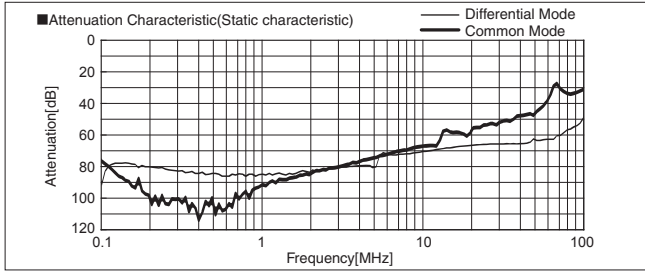

FSB-20-573-U

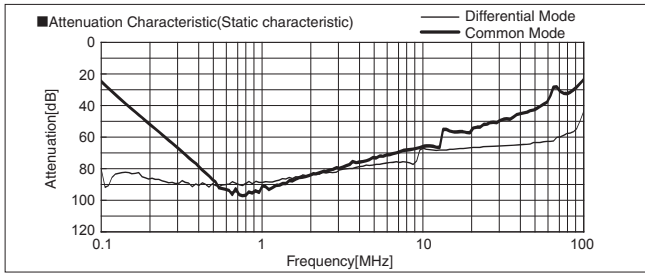

FSB-20-254-U

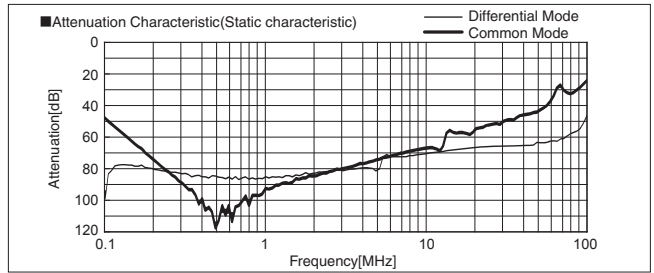

FSB-20-335-U

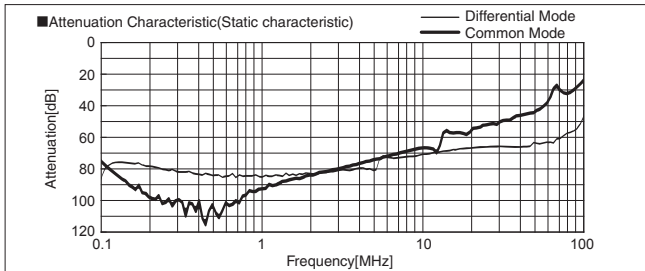

FSB-30-573-U

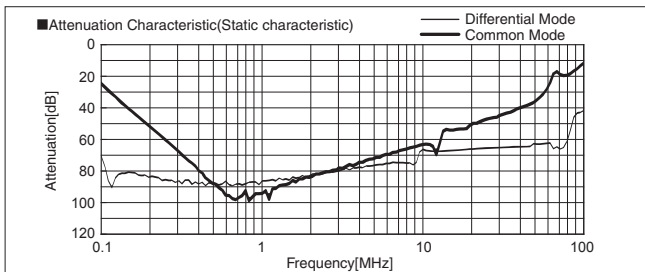

FSB-30-254-U

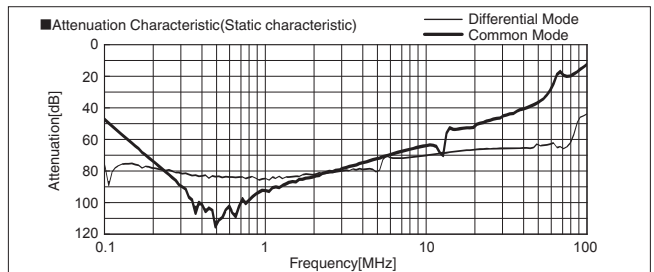

FSB-30-335-U

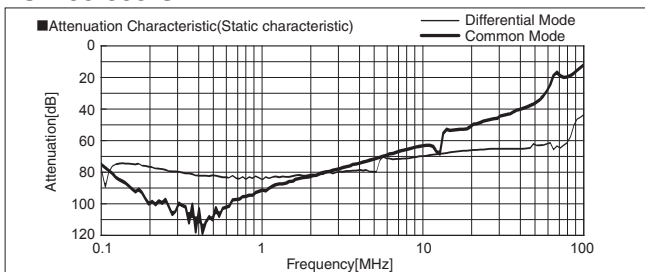

FSB series(40,50,60A)

FSB -60 -324 -□

① ② ③ ④



- ① Model Name
- ② Rated Current
- ③ Line to ground capacitor code: See table 1.1.

table 1.1 Line to ground capacitor code

Code	Leakage Current *1 Upper row : Δ-connection Lower row : Y-connection	Line to ground capacitor CY1 (nominal value)	Line to ground capacitor CY2 (nominal value)
203	1.0mA/2.0mA max 0.1mA/0.2mA max	0.01 μF	0.01 μF
693	2.5mA/5.0mA max 0.35mA/0.7mA max	0.022 μF	0.047 μF
104	3.5mA/7.0mA max 0.5mA/1.0mA max	0.033 μF	0.068 μF
324	12mA/24mA max 1.5mA/3.0mA max	0.1 μF	0.22 μF
355	180mA/270mA max 25mA/50mA max	0.22 μF	3.3 μF

* When the line to ground capacitor code is different, the attenuation characteristic is different.

*1 Input 250/500V 60Hz (Only Δ-connection of "355" is 250/400V 60Hz)

- ④ Option
- H : Ultra high-attenuation type
"355" is not applied.
- U : Improve differential mode attenuation
(Rated voltage 250V)

Features of FSB series

EMI/EMC Filter for motor drive system (AC servo)

- Improve saturation resistance (There is such as performance improvement type "-324-HU")
- Book type (Space-saving type)

Specifications

No.	Items	FSB-40-324	FSB-50-324	FSB-60-324
1	Rated Voltage[V]	AC Three Phase 500 (voltage range: 528 max) 50/60Hz *2 *3		
2	Rated Current[A]	40	50	60
3	Test Voltage (Terminal-Mounting Plate)	2,800 VDC (Cutoff Current = 10mA), 1minute at room temperature and humidity *4		
4	Isolation Resistance (Terminal-Mounting Plate)	500 VDC 100MΩ min at room temperature and humidity *5		
5	Leakage current 250/500V 60Hz	12mA/24mA max		
6	DC resistance	17mΩ max	14mΩ max	10mΩ max
7	Safety agency approval temperatures	-25 to +85°C (Refer to Derating Curve)		
8	Operating temperature	-40 to +85°C (Refer to Derating Curve)		
9	Operating humidity	20 to 95%RH (Non condensing)		
10	Storage temperature/humidity	-40 to +85°C/20 to 95%RH (Non condensing)		
11	Vibration	10 to 55Hz, 19.6m/s ² (2G), 3min. Period, 1hour each X, Y and Z axis		
12	Impact	196.1m/s ² (20G), 11ms Once each X, Y and Z axis		
13	Safety agency approvals	UL1283, CSA C22.2 No.8 (C-UL), DIN EN60939 VDE0565 Teil 3-1, ENEC		
14	Case size (without projection)	90 X 125 X 290 mm (W X H X D) [3.54 X 4.92 X 11.42 inches] (W X H X D)		
15	Weight	3.3kg max		

*2 Only capacitor code "355", Three Phase Δ-connection : 400 (440 max), Y-connection : 500 (528 max)

*3 Only "FSB-□□□□□□-U", Three Phase 250 (275 max)

*4 Only capacitor code "203", "693", "104", 2,500VAC (Cutoff Current = 100mA), 1minute at room temperature and humidity.

*5 Only capacitor code "355", Isolation resistance specification is deleted.

Circuit Diagram

(1) Line to ground capacitor code : 203, 693, 104, 324

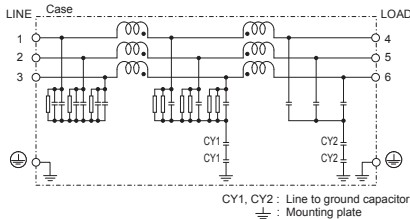

(2) Line to ground capacitor code : 355

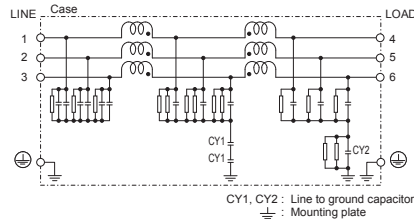

(3) Line to ground capacitor code : 203, 693, 104, 324
Option : U

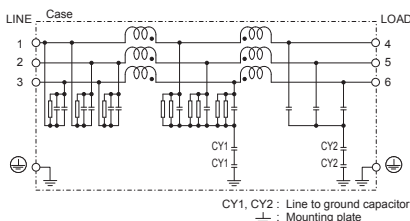

(4) Line to ground capacitor code : 355
Option : U

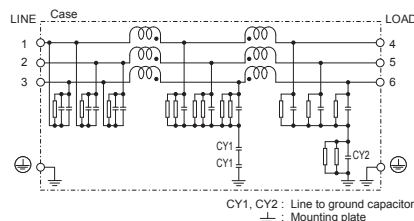

Derating Curve

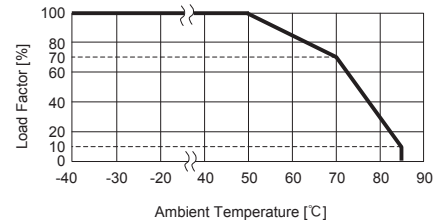

* Keep free ventilation holes for cooling.

External view

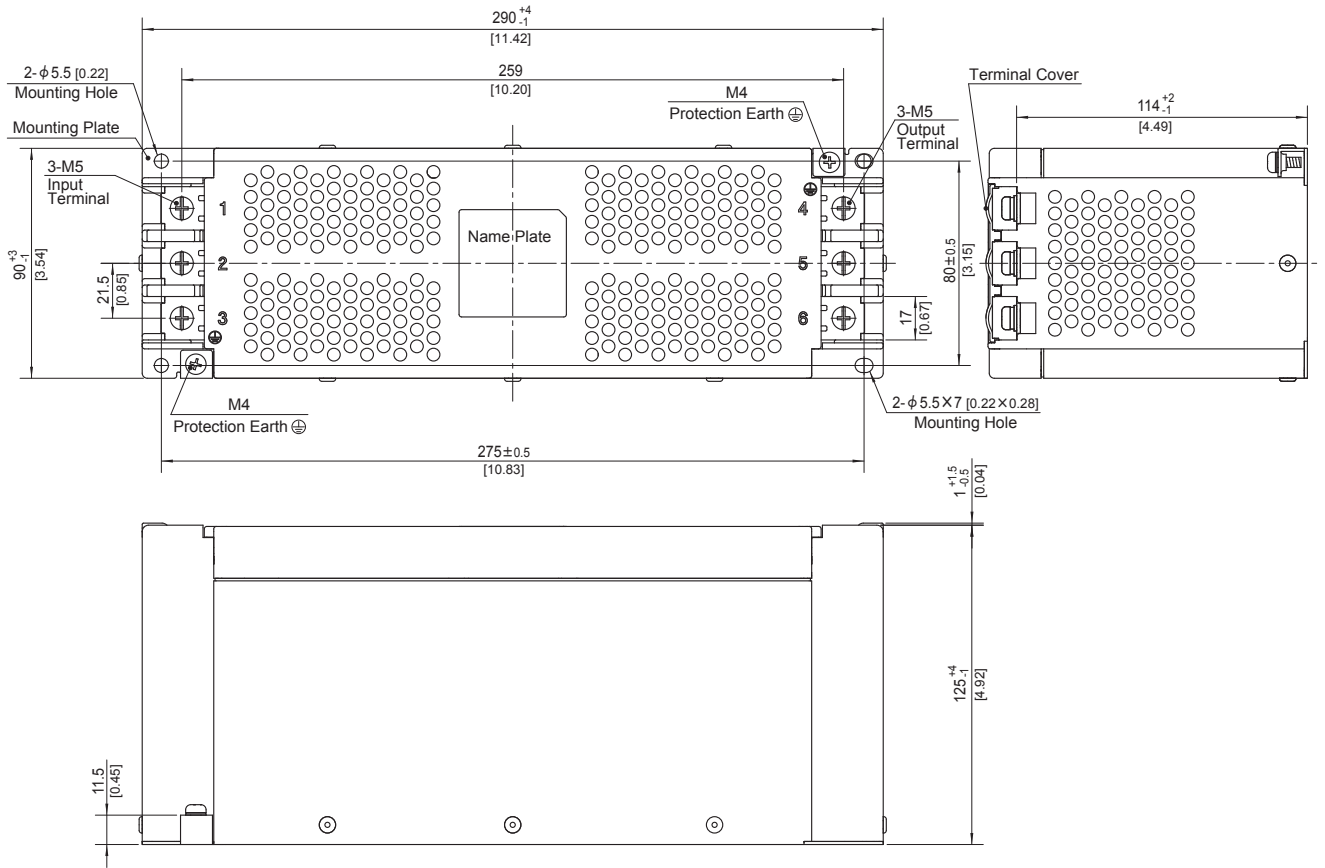

- ※ Tolerance : ± 1 [± 0.04]
- ※ Weight : 3.3kg max
- ※ Mounting Plate : Hot-dip Galvanized Steel board $t=1.2$ [0.05]
- ※ Case Material : PBT
- ※ Dimensions in mm, []=inches
- ※ Terminal block screw tightening torque M5 : $3.0\text{N} \cdot \text{m}$ (30.7kgf \cdot cm)max
- ※ Protection Earth(PE) screw tightening torque M4 : $1.6\text{N} \cdot \text{m}$ (16.9kgf \cdot cm)max
- ※ Can not be mounted upside-down(mounted the top surface)
- ※ Keep free ventilation holes for cooling

FSB-40-693

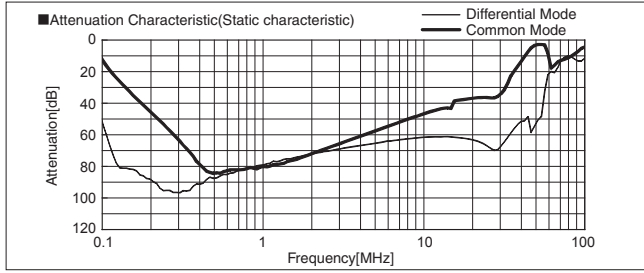

FSB-40-104

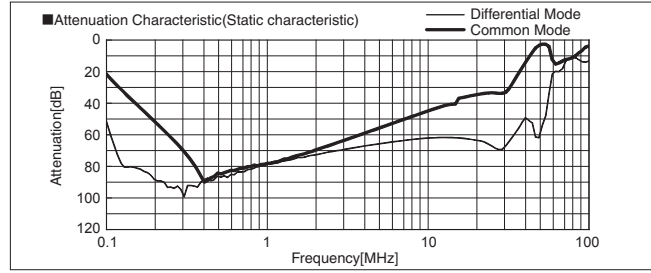

FSB-40-324

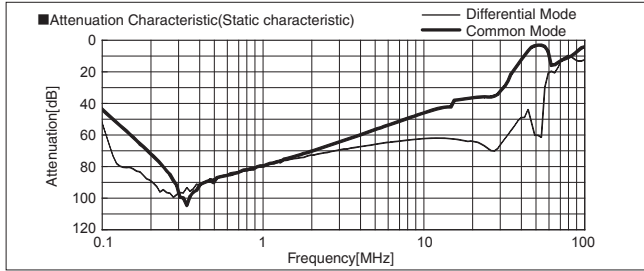

FSB-40-355

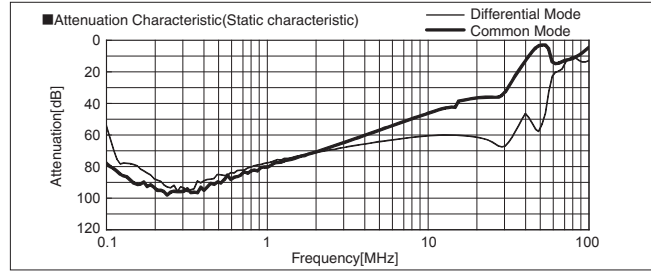

FSB-50-693

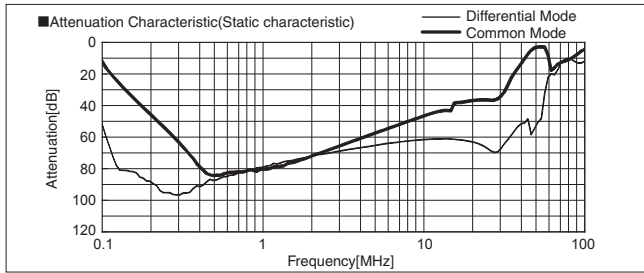

FSB-50-104

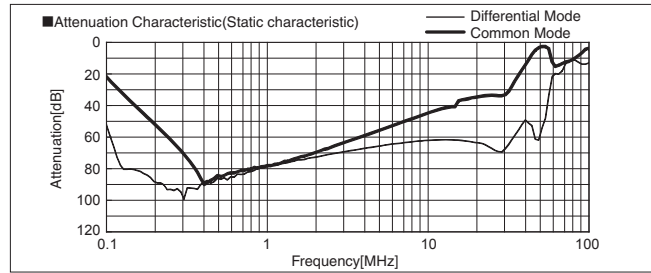

FSB-50-324

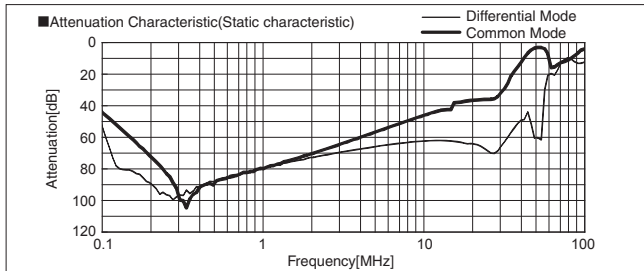

FSB-50-355

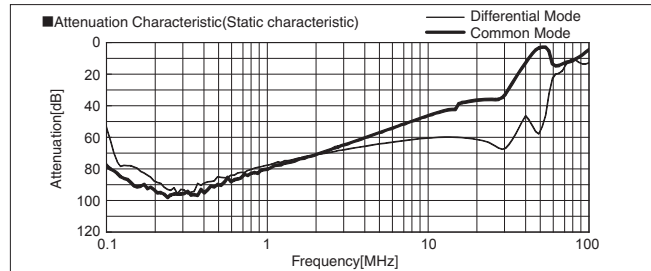

FSB-60-693

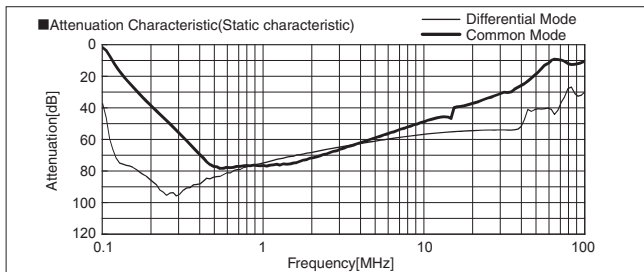

FSB-60-104

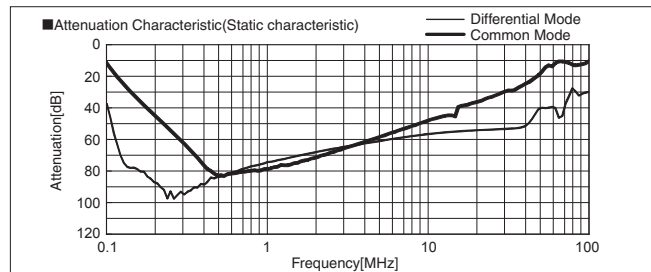

FSB-60-324

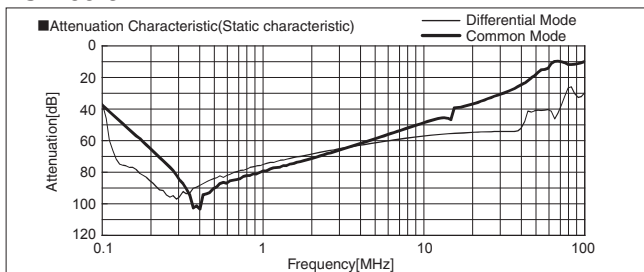

FSB-60-355

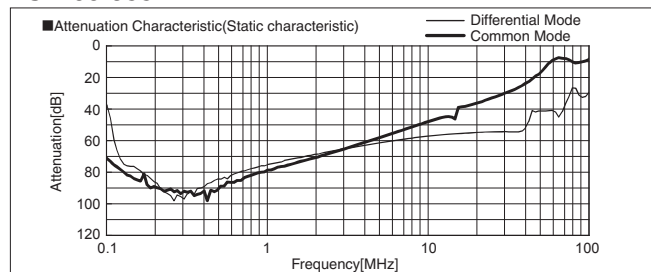

FSB-40-693-H

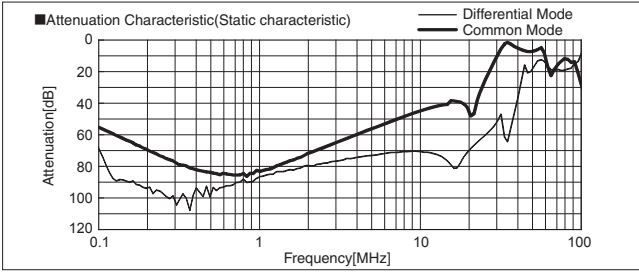

FSB-40-104-H

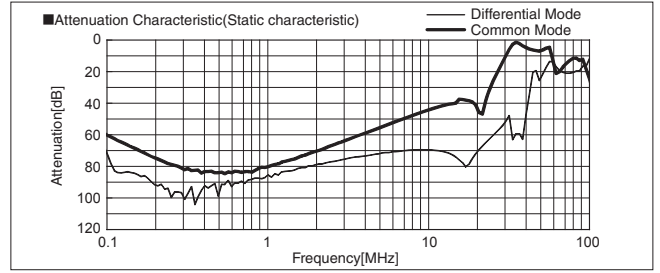

FSB-40-324-H

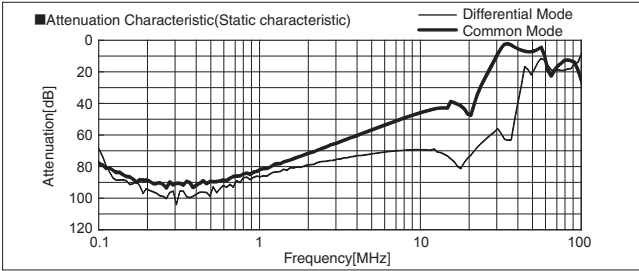

FSB-50-693-H

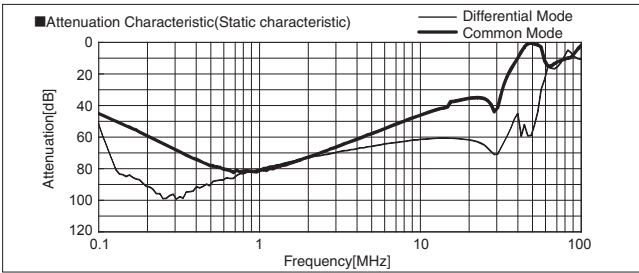

FSB-50-104-H

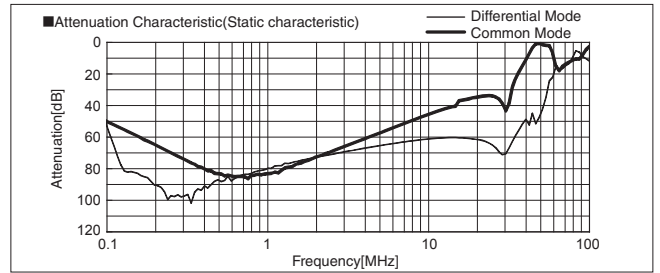

FSB-50-324-H

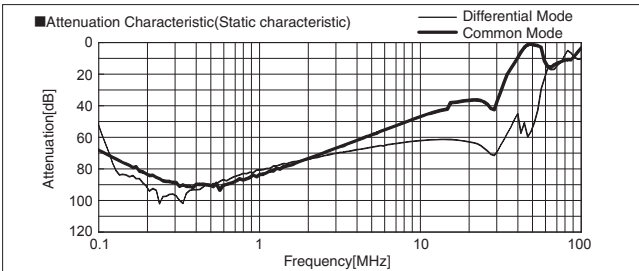

FSB-60-693-H

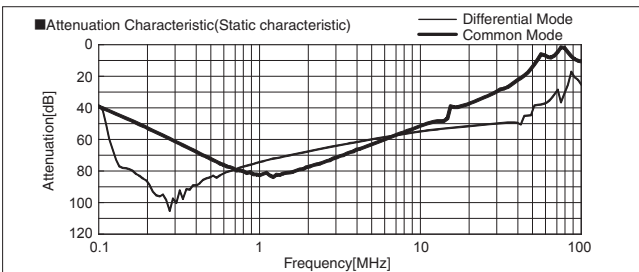

FSB-60-104-H

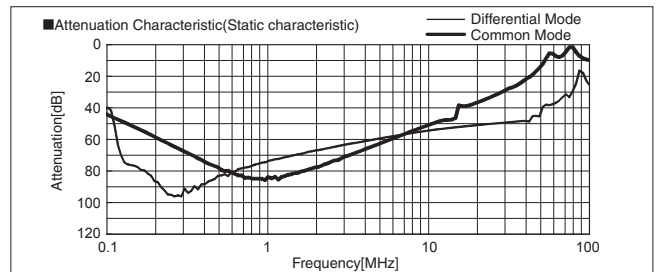

FSB-60-324-H

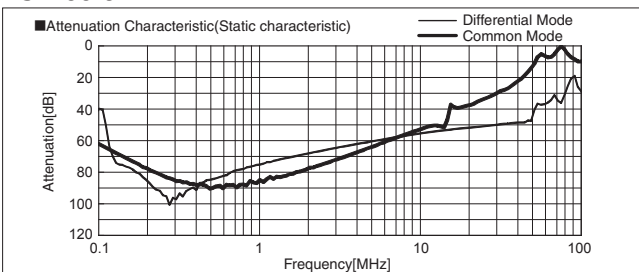

FSB-40-693-U

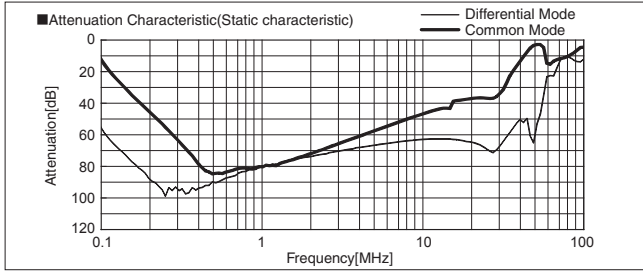

FSB-40-104-U

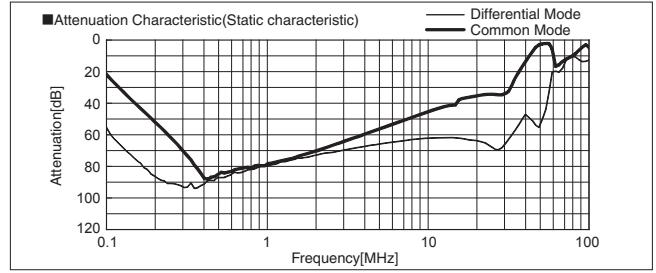

FSB-40-324-U

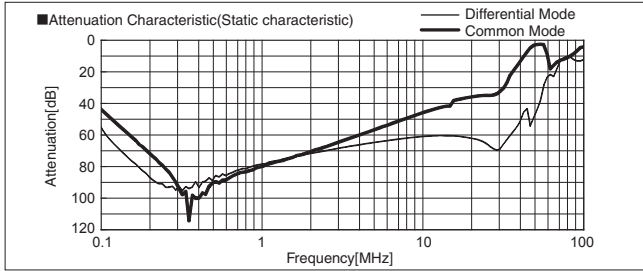

FSB-40-355-U

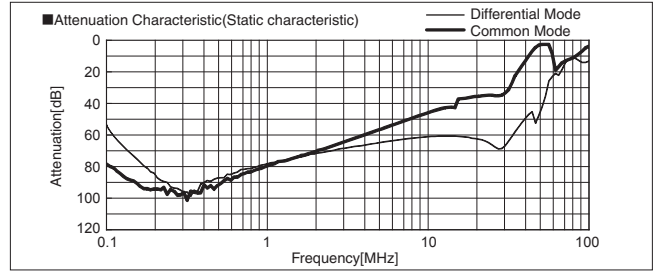

FSB-50-693-U

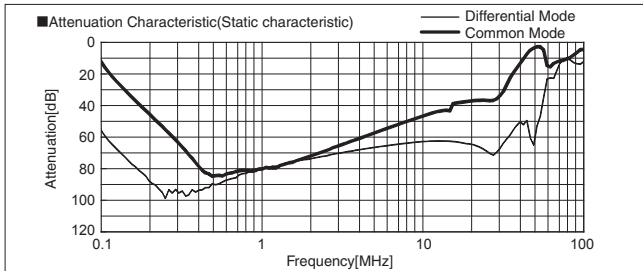

FSB-50-104-U

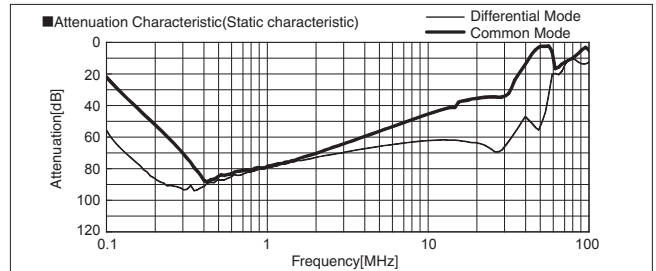

FSB-50-324-U

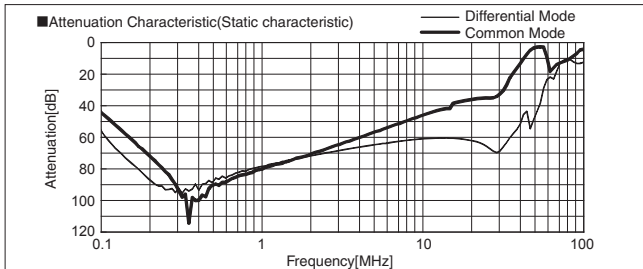

FSB-50-355-U

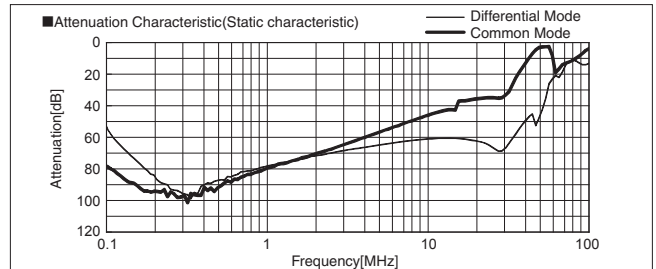

FSB-60-693-U

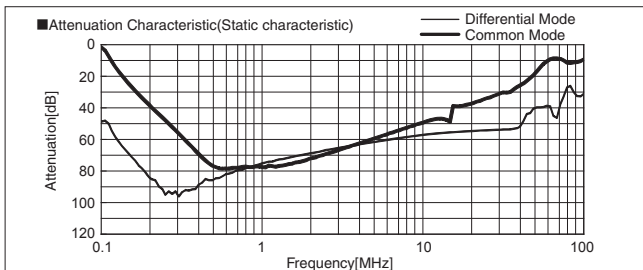

FSB-60-104-U

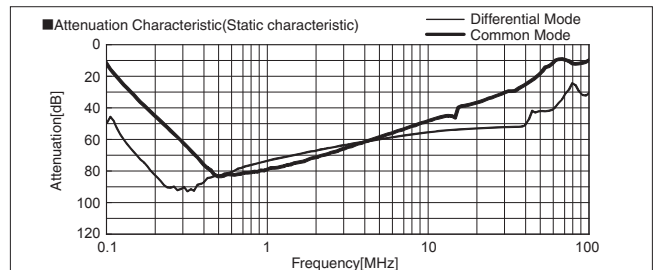

FSB-60-324-U

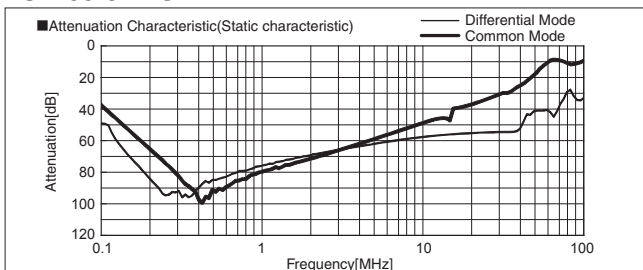

FSB-60-355-U

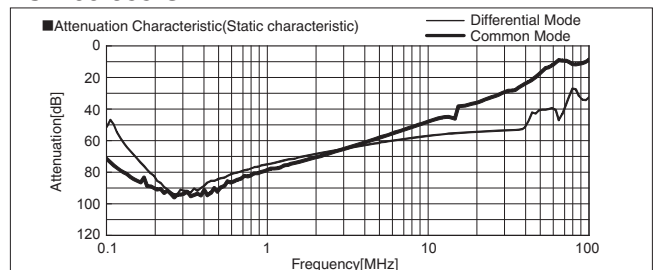

FSB series(80,100,150A)

FSB -150 -324 -□

① ② ③ ④



- ① Model Name
- ② Rated Current
- ③ Line to ground capacitor code: See table 1.1.

table 1.1 Line to ground capacitor code

Code	Leakage Current *1 Upper row : Δ-connection Lower row : Y-connection	Line to ground capacitor CY1 (nominal value)	Line to ground capacitor CY2 (nominal value)
203	1.0mA/2.0mA max 0.1mA/0.2mA max	0.01 μF	0.01 μF
693	2.5mA/5.0mA max 0.35mA/0.7mA max	0.022 μF	0.047 μF
104	3.5mA/7.0mA max 0.5mA/1.0mA max	0.033 μF	0.068 μF
324	12mA/24mA max 1.5mA/3.0mA max	0.1 μF	0.22 μF
355	330mA/515mA max 40mA/80mA max	0.22 μF	3.3 μF

* When the line to ground capacitor code is different, the attenuation characteristic is different.

*1 Input 250/500V 60Hz (Only Δ-connection of "355" is 250/400V 60Hz)

- ④ Option
- H : Ultra high-attenuation type
"355" is not applied.
- S : Hexagon socket head cap screw
(Standard type is Hexagon head screw)
- U : Improve differential mode attenuation
(Rated voltage 250V)

Features of FSB series

EMI/EMC Filter for motor drive system (AC servo)

- Improve saturation resistance (There is such as performance improvement type "-324-HU")
- Book type (Space-saving type)

Specifications

No.	Items	FSB-80-324	FSB-100-324	FSB-150-324
1	Rated Voltage[V]	AC Three Phase 500 (voltage range:528 max) 50/60Hz *2 *3		
2	Rated Current[A]	80	100	150
3	Test Voltage (Terminal-Mounting Plate)	2,800 VDC (Cutoff Current = 10mA), 1minute at room temperature and humidity *4		
4	Isolation Resistance (Terminal-Mounting Plate)	500 VDC 100MΩ min at room temperature and humidity *5		
5	Leakage current 250/500V 60Hz	12mA/24mA max		
6	DC resistance	10mΩ max	8mΩ max	6mΩ max
7	Safety agency approval temperatures	-25 to +85°C (Refer to Derating Curve)		
8	Operating temperature	-40 to +85°C (Refer to Derating Curve)		
9	Operating humidity	20 to 95%RH (Non condensing)		
10	Storage temperature/humidity	-40 to +85°C/20 to 95%RH (Non condensing)		
11	Vibration	10 to 55Hz, 19.6m/s ² (2G), 3min. Period, 1hour each X, Y and Z axis		
12	Impact	196.1m/s ² (20G), 11ms Once each X, Y and Z axis		
13	Safety agency approvals	UL1283, CSA C22.2 No.8 (C-UL), DIN EN60939 VDE0565 Teil 3-1, ENEC		
14	Case size (without projection)	100 X 170 X 350 mm (W X H X D)		100 X 210 X 400 mm (W X H X D)
		[3.94 X 6.69 X 13.78 inches] (W X H X D)		[3.94 X 8.27 X 15.75 inches] (W X H X D)
15	Weight	6.3kg max		

*2 Only capacitor code "355", Three Phase Δ-connection : 400 (440 max), Y-connection : 500 (528 max)

*3 Only "FSB-□□□□□□-U", Three Phase 250 (275 max)

*4 Only capacitor code "203", "693", "104", 2,500VAC (Cutoff Current = 100mA), 1minute at room temperature and humidity.

*5 Only capacitor code "355", Isolation resistance specification is deleted.

Circuit Diagram

(1) Line to ground capacitor code : 203, 693, 104, 324

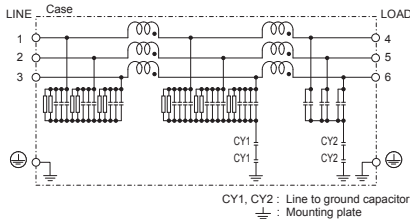

(2) Line to ground capacitor code : 355

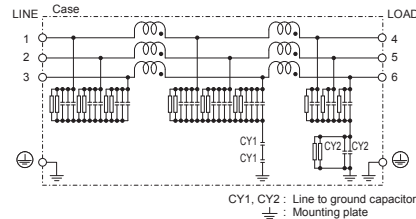

(3) Line to ground capacitor code : 203, 693, 104, 324
Option : U

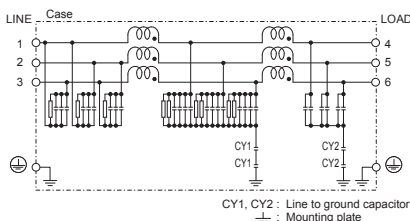

(4) Line to ground capacitor code : 355
Option : U

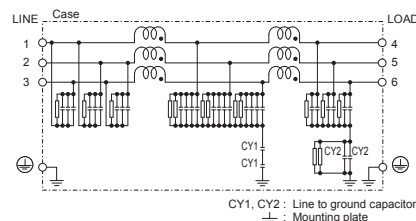

Derating Curve

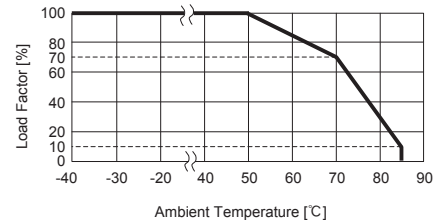

* Keep free ventilation holes for cooling.

External view

FSB-80 / FSB-100

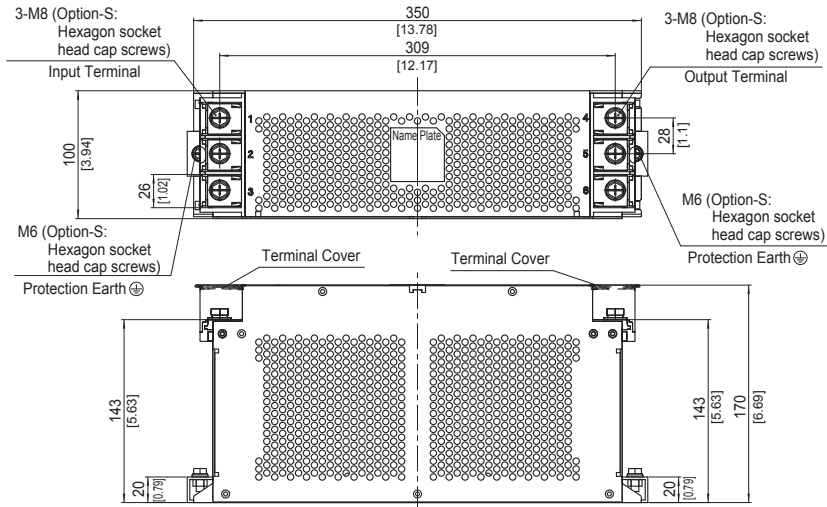

※ The air hole for heat radiation is not on the opposite side side.

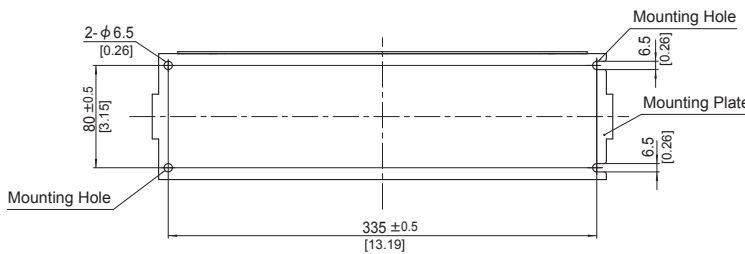

- ※ Tolerance : ± 1 [± 0.04]
- ※ Weight : 6.3kg max
- ※ Mounting Plate : Aluminum $t = 2.0$ [0.08]
- ※ Dimensions in mm, []=inches
- ※ Terminal block screw tightening torque
M8 : $9.2N \cdot m$ (93.9kgf · cm)max
- ※ Protection Earth (PE) screw tightening torque
M6 : $5.8N \cdot m$ (59.2kgf · cm)max
- ※ Can not be mounted upside-down
(mounted the top surface)
- ※ Keep free ventilation holes for cooling

FSB-150

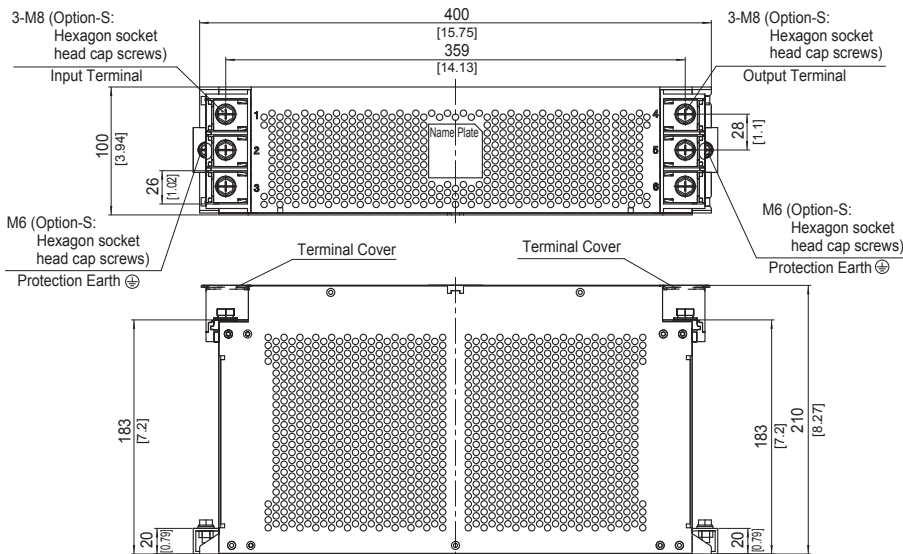

※ The air hole for heat radiation is not on the opposite side side.

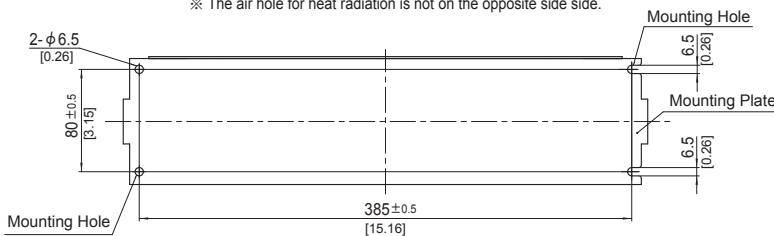

- ※ Tolerance : ± 1 [± 0.04]
- ※ Weight : 8.8kg max
- ※ Mounting Plate : Aluminum $t = 2.0$ [0.08]
- ※ Dimensions in mm, []=inches
- ※ Terminal block screw tightening torque
M8 : $9.2N \cdot m$ (93.9kgf · cm)max
- ※ Protection Earth (PE) screw tightening torque
M6 : $5.8N \cdot m$ (59.2kgf · cm)max
- ※ Can not be mounted upside-down
(mounted the top surface)
- ※ Keep free ventilation holes for cooling

FSB-80-693

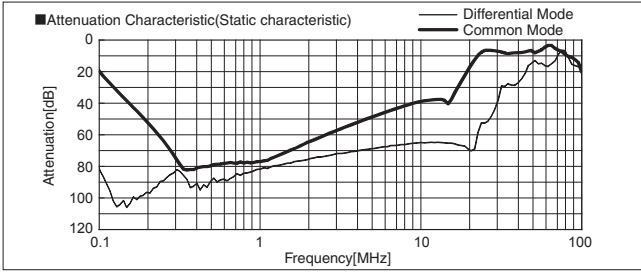

FSB-80-104

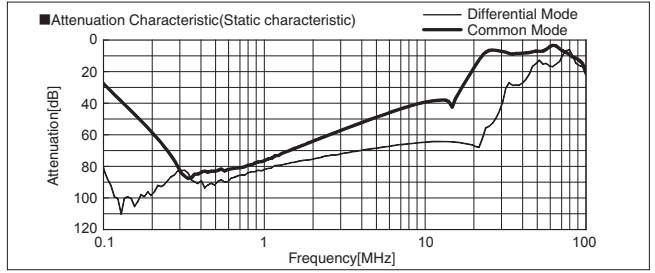

FSB-80-324

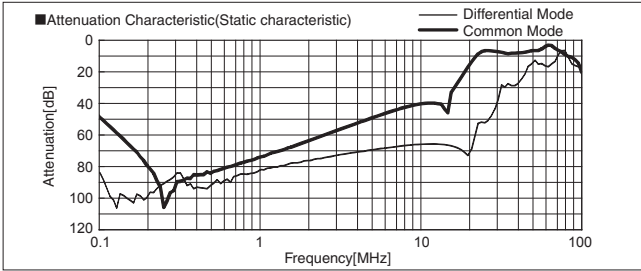

FSB-80-355

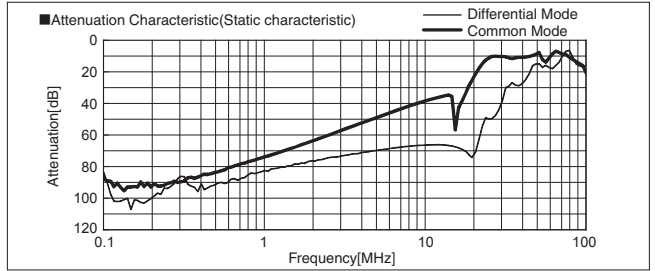

FSB-100-693

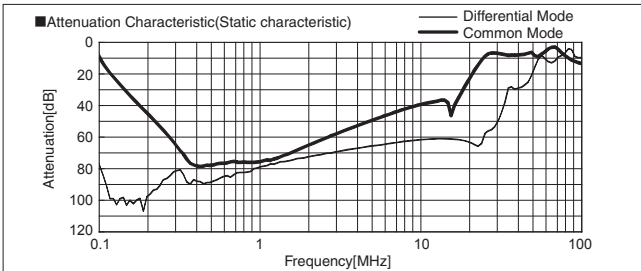

FSB-100-104

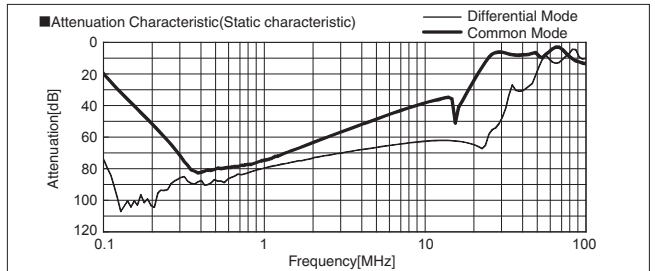

FSB-100-324

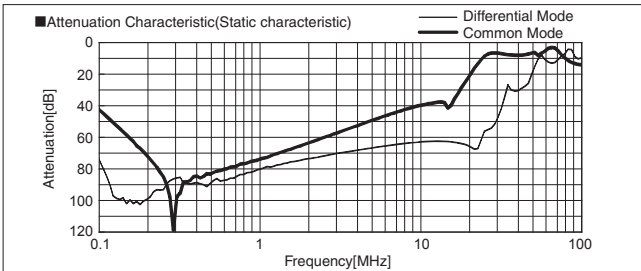

FSB-100-355

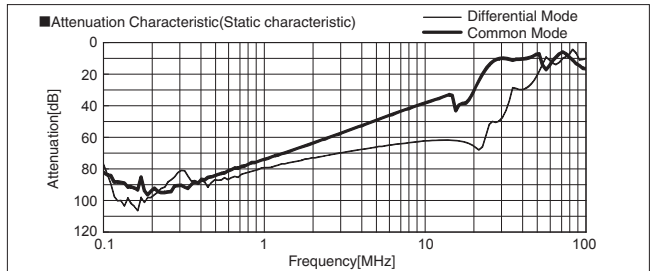

FSB-150-693

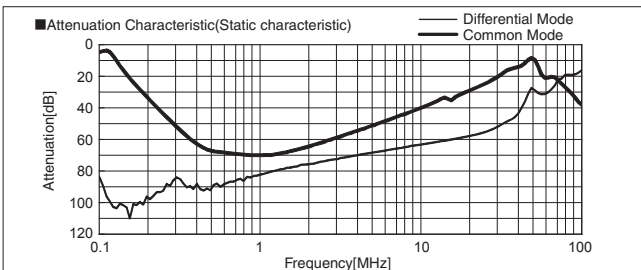

FSB-150-104

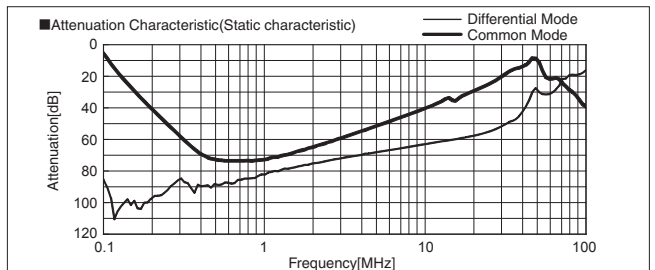

FSB-150-324

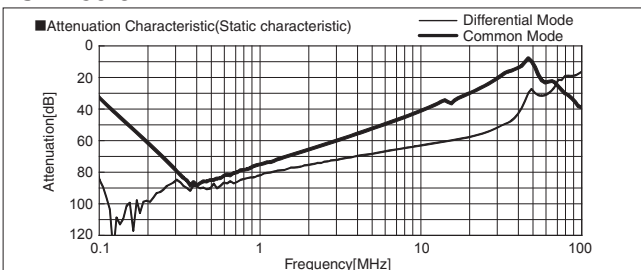

FSB-150-355

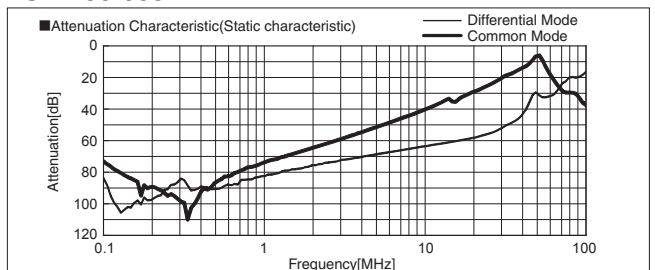

FSB-80-693-H

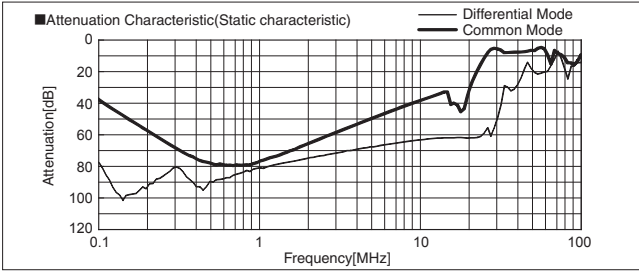

FSB-80-104-H

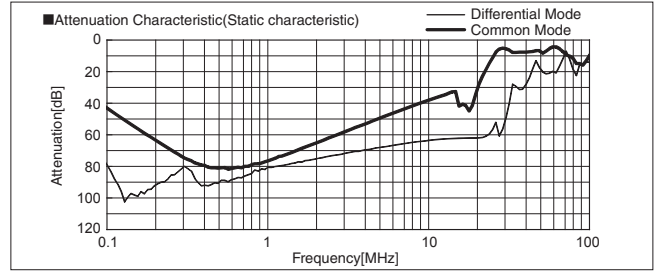

FSB-80-324-H

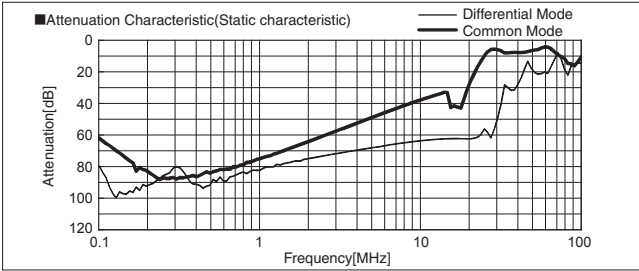

FSB-100-693-H

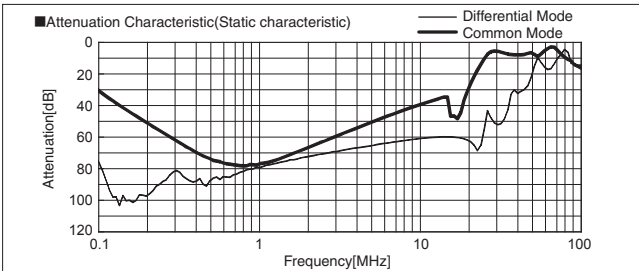

FSB-100-104-H

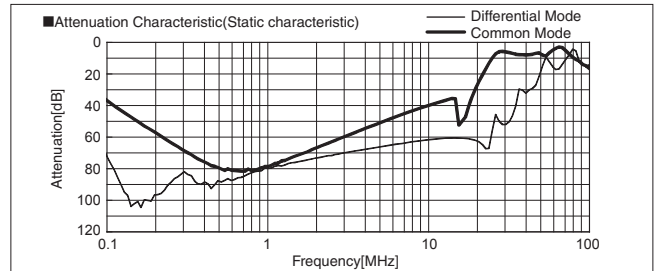

FSB-100-324-H

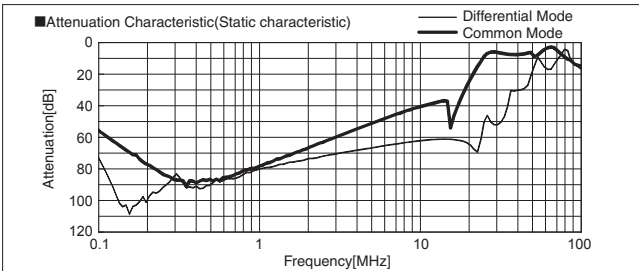

FSB-150-693-H

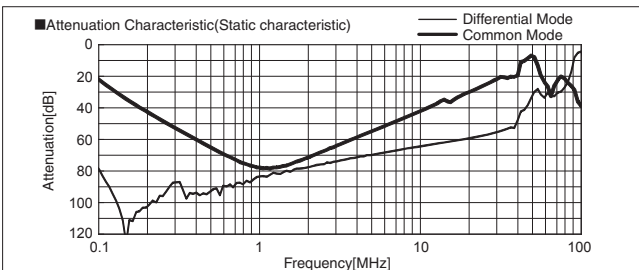

FSB-150-104-H

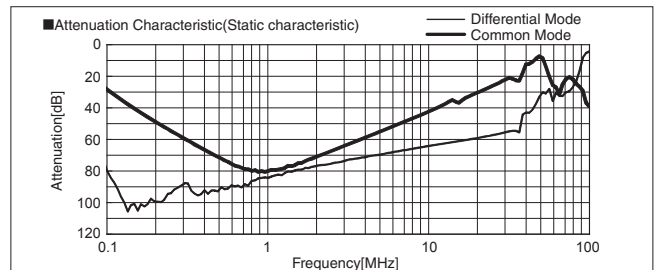

FSB-150-324-H

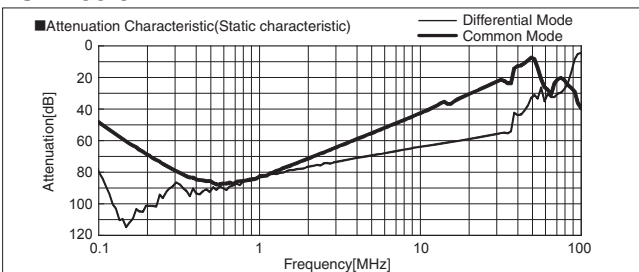

FSB-80-693-U

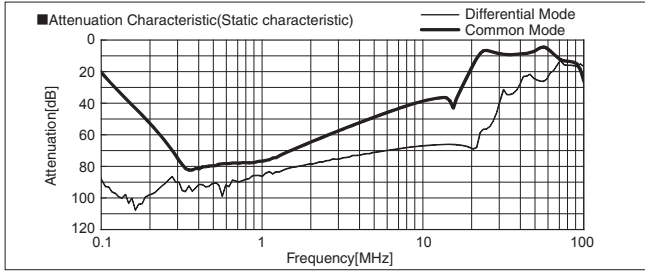

FSB-80-104-U

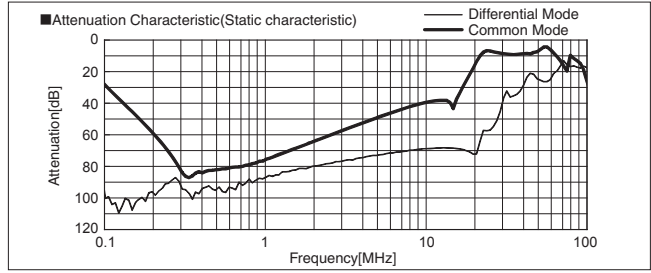

FSB-80-324-U

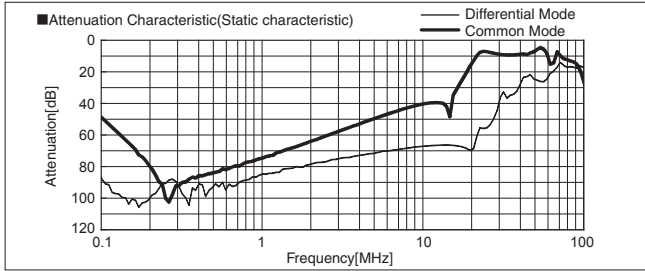

FSB-80-355-U

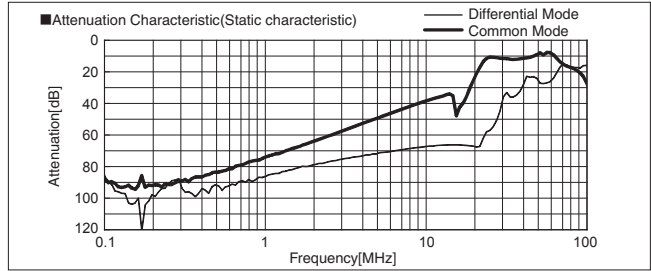

FSB-100-693-U

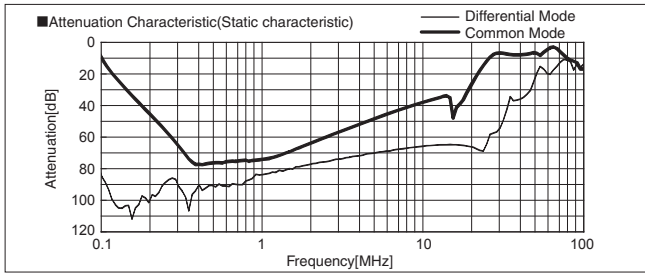

FSB-100-104-U

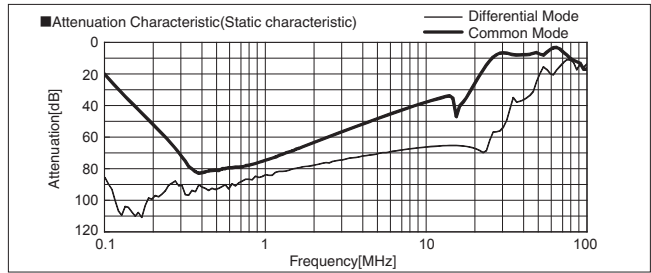

FSB-100-324-U

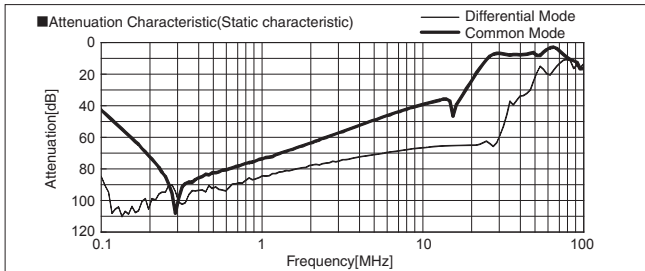

FSB-100-355-U

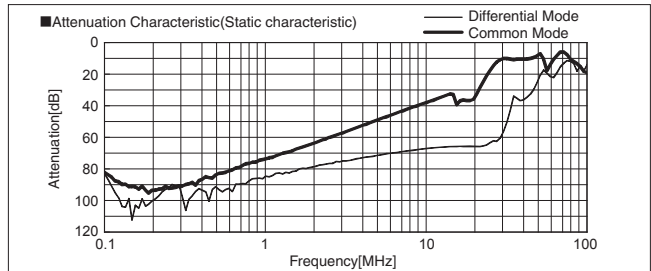

FSB-150-693-U

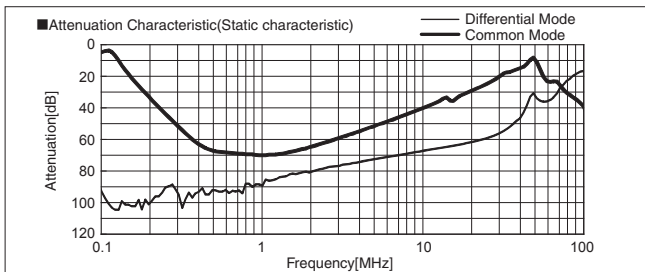

FSB-150-104-U

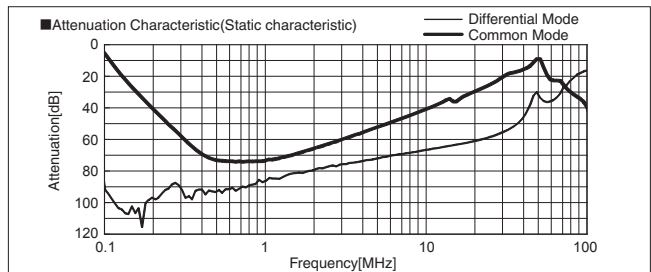

FSB-150-324-U

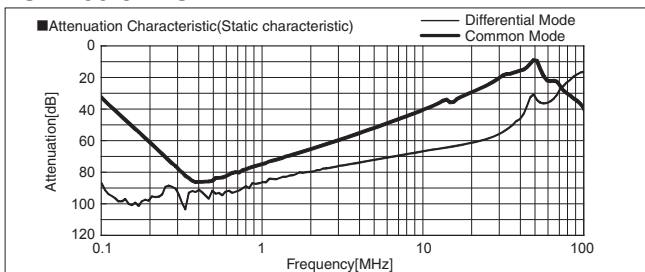

FSB-150-355-U

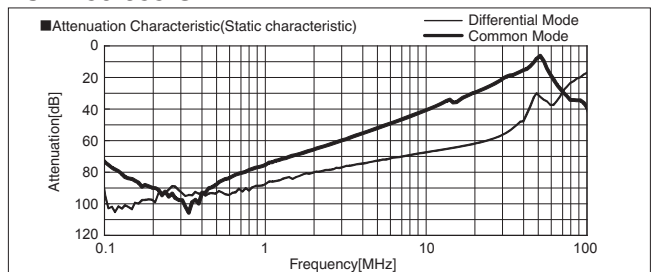

TSC series(400,600A)

TSC -600 -665 -□

① ② ③ ④

- ① Series Name
- ② Rated Current
- ③ Line to ground capacitor code: See table 1.1

table1.1 Line to ground capacitor code

Code	Leakage Current		Line to ground capacitor (nominal value)		
	Upper row : Δ-connection	Lower row : Y-connection	CY1	CY2	CY3
000*1	50μA/100μA max	50μA/100μA max	Not Provided	Not Provided	Not Provided
304*1	10.5mA/21.0mA max	1.5mA/3.0mA max	0.1μF	0.1μF	0.1μF
664*1	23mA/46mA max	3.5mA/7.0mA max	0.22μF	0.22μF	0.22μF
665*2	220mA/350mA max	20mA/40mA max	2.2μF	2.2μF	2.2μF

- * When the line to ground capacitor code is different, the attenuation characteristic is different.
- * Please contact us about low leakage current type (Change to low grounding capacitor).
- *1 Δ-connection : Input 250/500V 60Hz
Y-connection : Input 250/500V 60Hz
- *2 Δ-connection : Input 250/400V 60Hz
Y-connection : Input 250/500V 60Hz

- ④ Option
- H: Ultra high-attenuation type

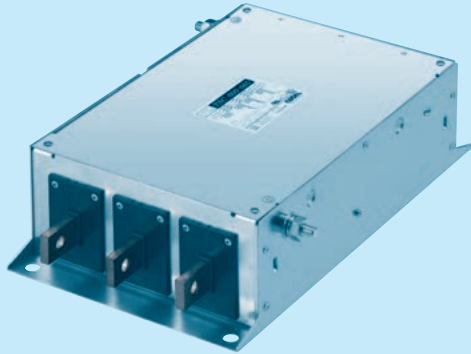

Features of TSC series

- Ultra high-attenuation type of common mode noise from 150kHz to 1MHz (Multi-stage filter)
- Input and output terminals : Busbar type
- Target application: Solar photovoltaic system, Large production equipment
- Selectable leakage current value

Specifications

No.	Items	TSC-400-665	TSC-600-665
1	Rated Voltage[V]	AC Three Phase 500(voltage range:528 max)	50/60Hz *3
2	Rated Current[A]	400	600
3	Test Voltage (Terminal-Mounting Plate)	3,600 VDC (Cutoff Current = 10mA), 1minute at room temperature and humidity	
4	Leakage current 250/500V 60Hz	20mA/40mA max (Y-connection)	
5	DC resistance	0.27mΩ max	0.2mΩ max
6	Safety agency approval temperatures	-25 to +85°C (Refer to Derating Curve)	
7	Operating temperature	-40 to +85°C (Refer to Derating Curve)	
8	Operating humidity	20 to 95%RH (Non condensing)	
9	Storage temperature/humidity	-40 to +85°C/20 to 95%RH (Non condensing)	
10	Vibration	10 to 55Hz, 9.8m/s ² (1G), 3min. Period, 1hour each X, Y and Z axis	
11	Impact	98.1m/s ² (10G), 11ms Once each X, Y and Z axis	
12	Safety agency approvals	UL1283, CSA C22.2 No.8 (C-UL) , DIN EN60939 VDE0565 Teil3-1, ENEC	
13	Case size (without projection)	210 X 100 X 360 mm [8.27 X 3.94 X 14.17 inches] (W X H X D)	
14	Weight	9.5kg max	10.0kg max

*3 Only capacitor code "665", Three Phase Δ-connection : 400 (440 max), Y-connection : 500 (528 max)

Circuit Diagram

(1) Line to ground capacitor code : 000

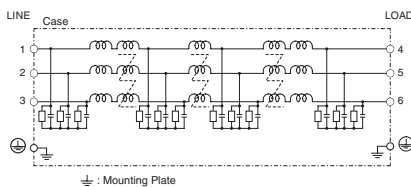

(2) Line to ground capacitor code : 304, 664, 665

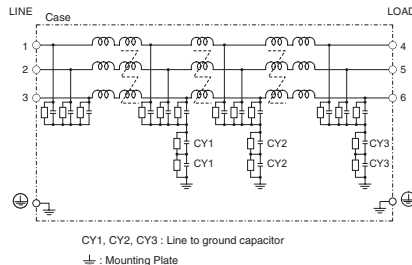

Derating Curve

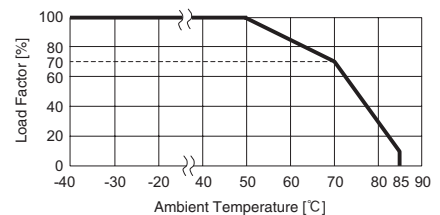

External view

TSC-400

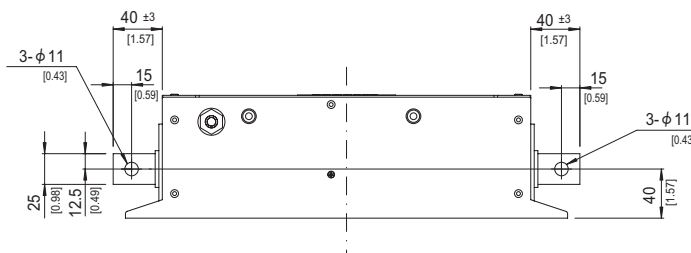
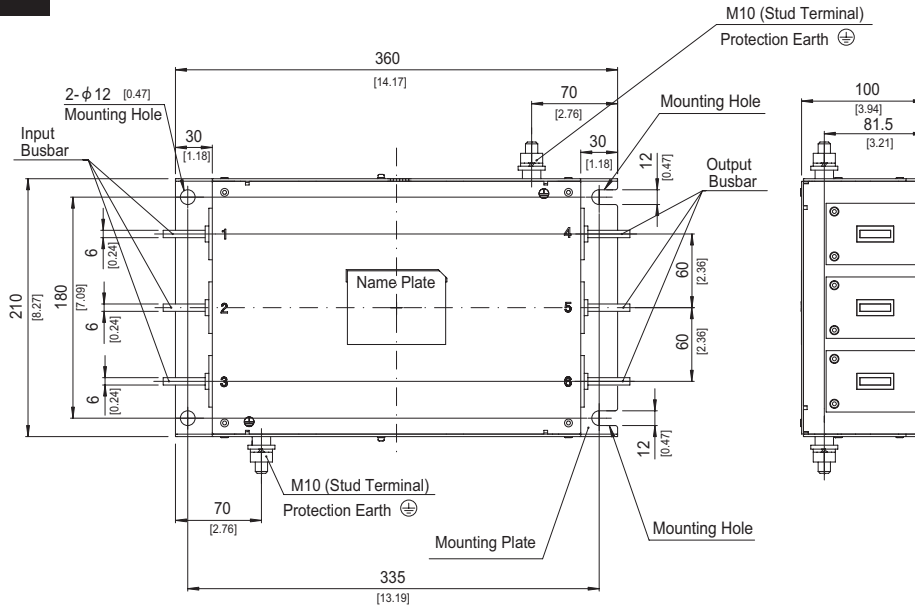

- ※ Tolerance : ± 1 [± 0.04]
- ※ Weight : 9.5kg max
- ※ Mounting Plate : Aluminum t=2.0 [0.08]
- ※ Busbar : Copper (Unplated) t=6.0 [0.24]
- ※ Dimensions in mm, []=inches
- ※ Protection Earth (PE) screw tightening torque
M10 : 14.2N · m (144.9kgf · cm)max
- ※ Can not be mounted upside-down
(mounted the top surface)

TSC-600

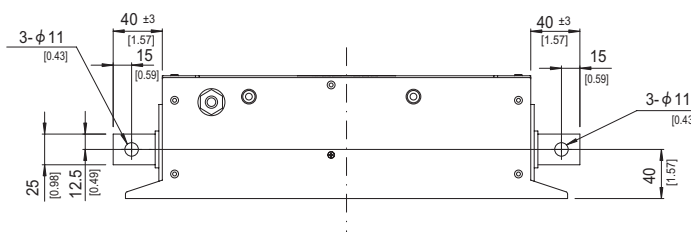
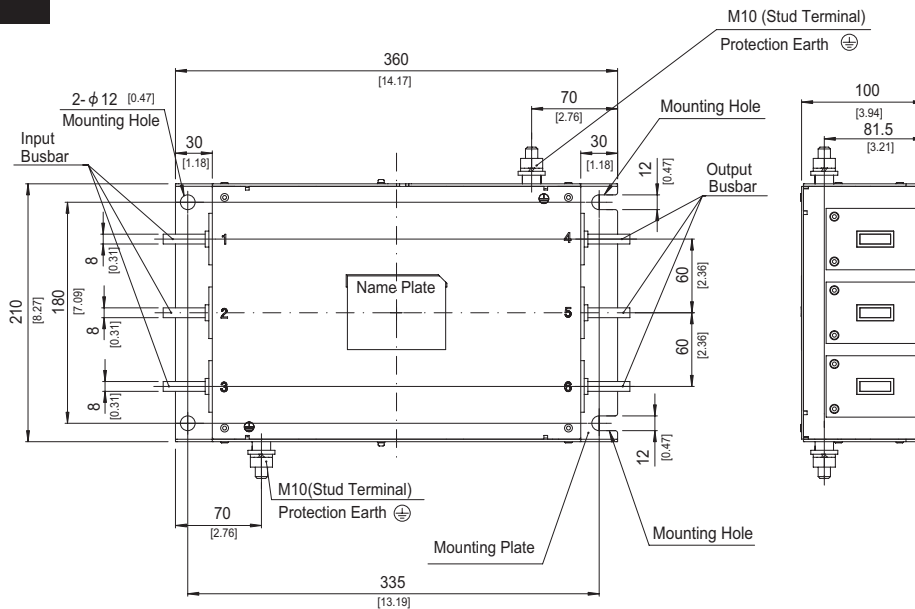

- ※ Tolerance : ± 1 [± 0.04]
- ※ Weight : 10.0kg max
- ※ Mounting Plate : Aluminum t=2.0 [0.08]
- ※ Busbar : Copper (Unplated) t=8.0 [0.31]
- ※ Dimensions in mm, []=inches
- ※ Protection Earth (PE) screw tightening torque
M10 : 14.2N · m (144.9kgf · cm)max
- ※ Can not be mounted upside-down
(mounted the top surface)

TSD series(400,600A)

TSD -600 -186

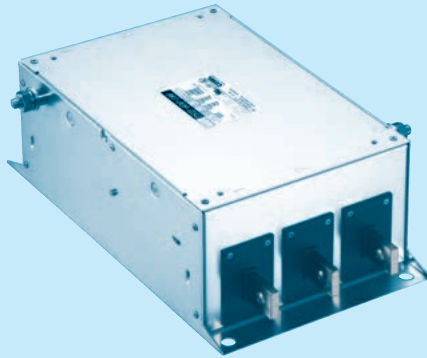

① Series Name ② Rated Current
 ③ Line to ground capacitor code: See table 1.1
 table.1.1 Line to ground capacitor code

Code	Leakage Current *1 Upper row : Δ-connection Lower row : Y-connection	Line to ground capacitor (nominal value)		
		CY1	CY2	CY3
105	45mA/70mA max 3.5mA/7mA max	0.22μF	0.1μF	0.22μF
215	80mA/130mA max 7.5mA/15mA max	1.0μF	0.1μF	1.0μF
665	220mA/350mA max 20mA/40mA max	2.2μF	2.2μF	2.2μF
136	420mA/660mA max 40mA/80mA max	2.2μF	2.2μF	2.2μF
186	540mA/850mA max 50mA/100mA max	2.2μF	2.2μF	2.2μF

* When the line to ground capacitor code is different, the attenuation characteristic is different.
 * Please contact us about low leakage current type. (Change to low grounding capacitor)
 *1 Δ-connection : Input 250/400V 60Hz
 Y-connection : Input 250/500V 60Hz

Features of TSD series

Ultra high-attenuation type for motor drive system (Multi-functional regenerative converter)

- Improve saturation resistance
- Input and output terminals : Busbar type
- Target application: Large equipment with Multi-functional regenerative convertor (Transferred equipment, Air conditioning equipment)

Specifications

No.	Items	TSD-400-186	TSD-600-186
1	Rated Voltage[V]	AC Three Phase Y-connection 500 (voltage range:528 max) 50/60Hz *2	
2	Rated Current[A]	400	600
3	Test Voltage (Terminal-Mounting Plate)	3,600 VDC (Cutoff Current = 10mA), 1minute at room temperature and humidity	
4	Leakage current 250/500V 60Hz	50mA/100mA max (Y-connection)	
5	DC resistance	0.27mΩ max	0.2mΩ max
6	Safety agency approval temperatures	-40 to +85°C (Refer to Derating Curve)	
7	Operating temperature	-40 to +85°C (Refer to Derating Curve)	
8	Operating humidity	20 to 95%RH (Non condensing)	
9	Storage temperature/humidity	-40 to +85°C/20 to 95%RH (Non condensing)	
10	Vibration	10 to 55Hz, 9.8m/s ² (1G), 3min. Period, 1hour each X, Y and Z axis	
11	Impact	98.1m/s ² (10G), 11ms Once each X, Y and Z axis	
12	Safety agency approvals	UL60939 [Overvoltage Category : III Altitude 3000m] , CSA C22.2 No.8 (C-UL) EN60939 (DEMKO) [Overvoltage Category: III Altitude 3000m] , ENEC	
13	Case size (without projection)	210×125×360 mm [8.27 X 4.92 X 14.17 inches] (W X H X D)	
14	Weight	10.0kg max	10.5kg max

*2 Three Phase Δ-connection:400V (440V max)

Circuit Diagram

(1) Line to ground capacitor code : 105

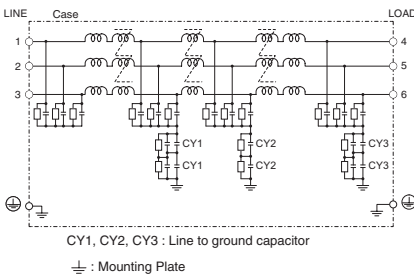

(2) Line to ground capacitor code : 215,665

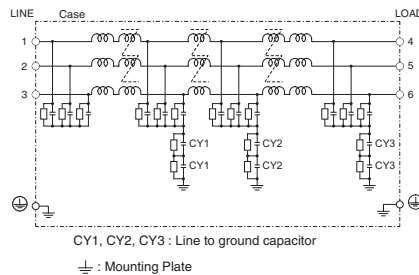

(3) Line to ground capacitor code : 136

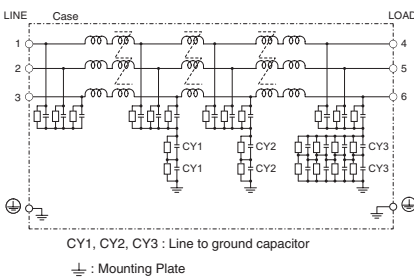

(4) Line to ground capacitor code : 186

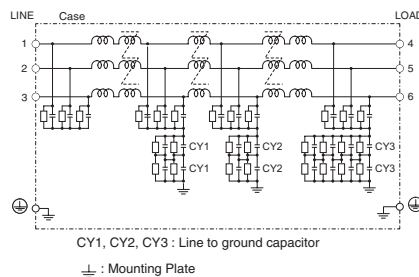

Derating Curve

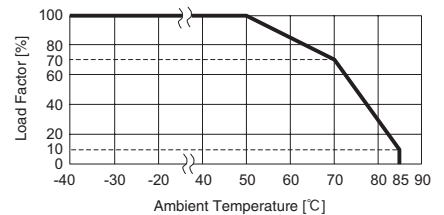

External view

TSD-400

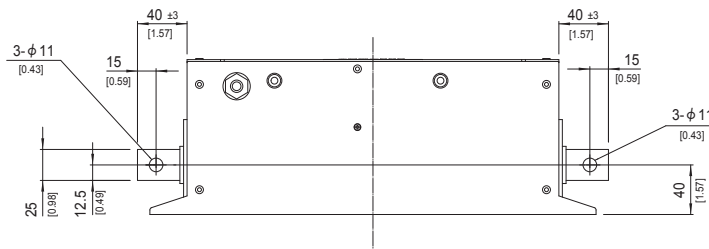
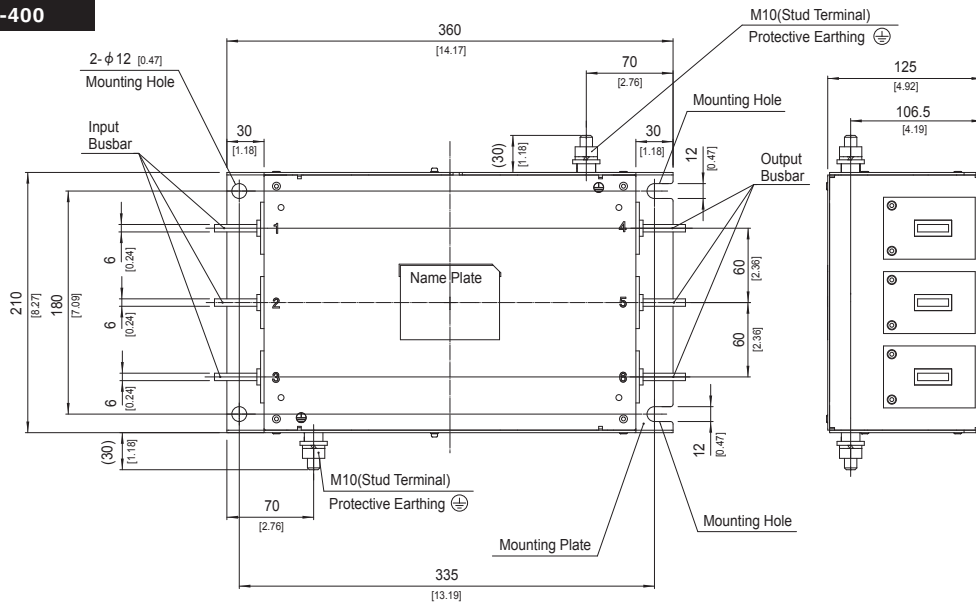

- ※ Dimensions in mm, [] = inches
- ※ Tolerance : ±1 [±0.04]
- ※ Weight : 10.0kg max
- ※ Mounting Plate : Aluminum t = 2.0 [0.08]
- ※ Busbar : Copper (Unplated) t = 6.0 [0.24]
- ※ Protective Earthing (PE) screw tightening torque M10 : 14.2N · m max
- ※ Can not be mounted upside-down (mounted the top surface)

TSD-600

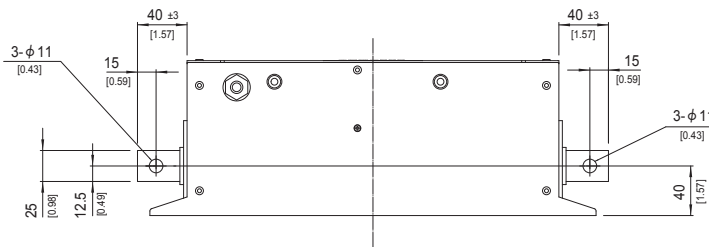
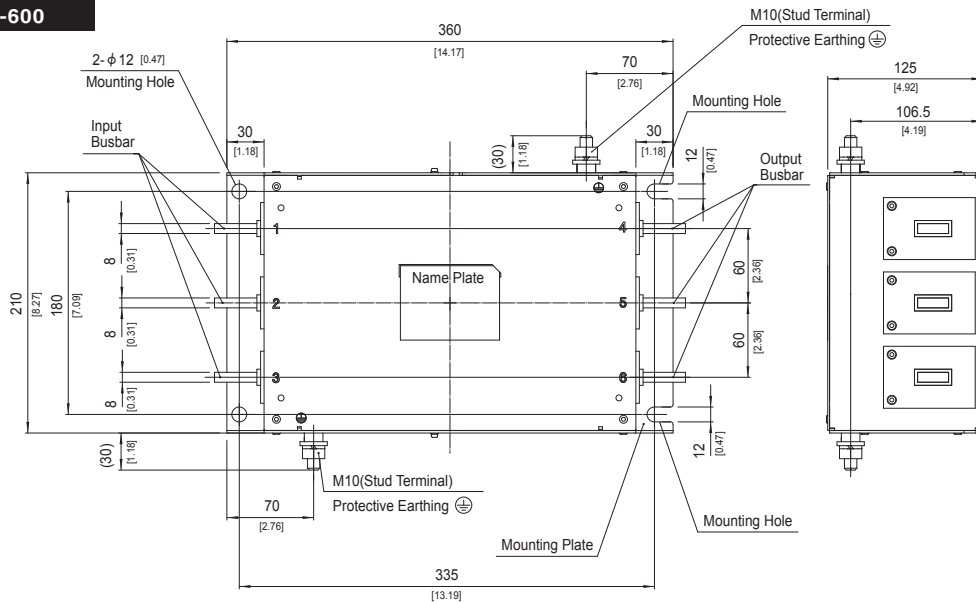

- ※ Dimensions in mm, [] = inches
- ※ Tolerance : ±1 [±0.04]
- ※ Weight : 10.5kg max
- ※ Mounting Plate : Aluminum t = 2.0 [0.08]
- ※ Busbar : Copper (Unplated) t = 8.0 [0.31]
- ※ Protective Earthing (PE) screw tightening torque M10 : 14.2N · m max
- ※ Can not be mounted upside-down (mounted the top surface)

TSD series(800,1000A)

TSD -1000 -356

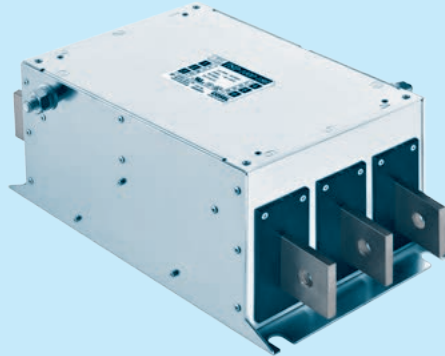

- ① Series Name
- ② Rated Current
- ③ Line to Ground Capacitor Code: See Table 1.1

Table 1.1 Line to Ground Capacitor Code

Code	Leakage Current Upper row : Δ-Connection Lower row : Y-Connection	Line to Ground Capacitor (Nominal Value)		
		CY1	CY2	CY3
000 *1	50uA/100uA max 50uA/100uA max	Not Provided	Not Provided	Not Provided
304 *1	10.5mA/21.0mA max 1.5mA/3.0mA max	0.1μF X1	0.1μF X1	0.1μF X1
664 *1	23mA/46mA max 3.5mA/7.0mA max	0.22μF X1	0.22μF X1	0.22μF X1
316 *2	960mA/1500mA max 90mA/180mA max	2.2μF X2	2.2μF X2	2.2μF X10
356 *2	1080mA/1700mA max 100mA/200mA max	2.2μF X4	2.2μF X4	2.2μF X8
446 *2	1300mA/2100mA max 110mA/220mA max	2.2μF X5	2.2μF X5	2.2μF X10

*When the line to ground capacitor code is different, the attenuation characteristic is different.

*Please contact us about low leakage current type (Change to low grounding capacitor).

*1 Δ-Connection : Input 250/500V 60Hz
Y-Connection : Input 250/500V 60Hz

*2 Δ-Connection : Input 250/400V 60Hz
Y-Connection : Input 250/400V 60Hz

Features of TSD series

Ultra high-attenuation type for motor drive system (Multi-functional regenerative converter)

- Improve saturation resistance
- Input and output terminals : Busbar type
- Target application: Large equipment with Multi-functional regenerative convertor (Transferred equipment, Air conditioning equipment)

Specifications

No.	Items	TSD-800-356	TSD-1000-356
1	Rated Voltage	[VAC]	Three-phase Y-Connection 500 (Voltage Range:528 max) 50/60Hz *3
		[VDC]	610
2	Rated Current[A]	800	1000
3	Test Voltage (Terminal-Mounting Plate)	3,600 VDC (Cutoff Current = 10mA), 1minute at room temperature and humidity *4	
4	Leakage Current 250/500V 60Hz (Y-Connection)	100mA / 200mA max	
5	DC Resistance	0.1mΩ max	
6	Operating Temperature/Humidity	-40 to +85°C (Refer to Derating Curve)/20 to 95%RH (Non condensing)	
7	Storage Temperature/Humidity	-40 to +85°C/20 to 95%RH (Non condensing)	
8	Vibration	10 to 55Hz, 9.8m/s ² (1G), 3min. Period, 1hour each X, Y and Z axis	
9	Impact	98.1m/s ² (10G), 11ms Once each X, Y and Z axis	
10	Safety Agency Approvals	UL60939 [Overvoltage Category : III Altitude : 3000m], CSA C22. 2 No. 8 (C-UL) EN60939 (DEMKO) [Overvoltage Category: III Altitude : 3000m], ENEC	
11	Case Size (Without Projection)	190 X 155 X 346mm (W×H×D) [7.48 X 6.10 X 13.62 inches] (W X H X D)	
12	Weight	11.5kg max	

*3 Line to Ground Capacitor Code 「186」, 「356」, 「446」, Three-Phase Δ-Connection:400V (440V max), Three-Phase Y-Connection:500V (528V max)

*4 Line to Ground Capacitor Code 「000」, 2,500 VAC (Cutoff Current = 5mA), 1minute at room temperature and humidity

Circuit Diagram

(1) Line to Ground Capacitor Code : 000

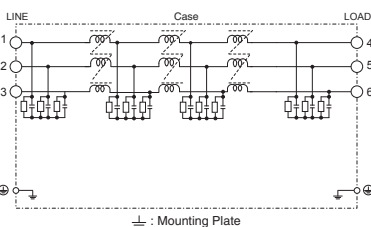

(2) Line to Ground Capacitor Code : 304, 664, 316, 356, 446

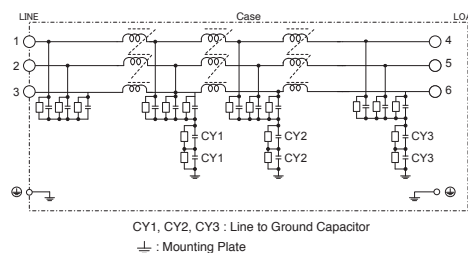

Derating Curve

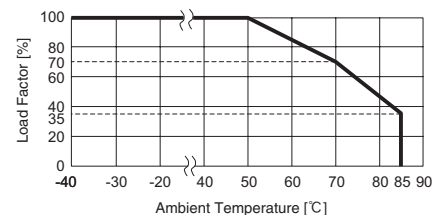

External view

TSD-800/1000-□□□

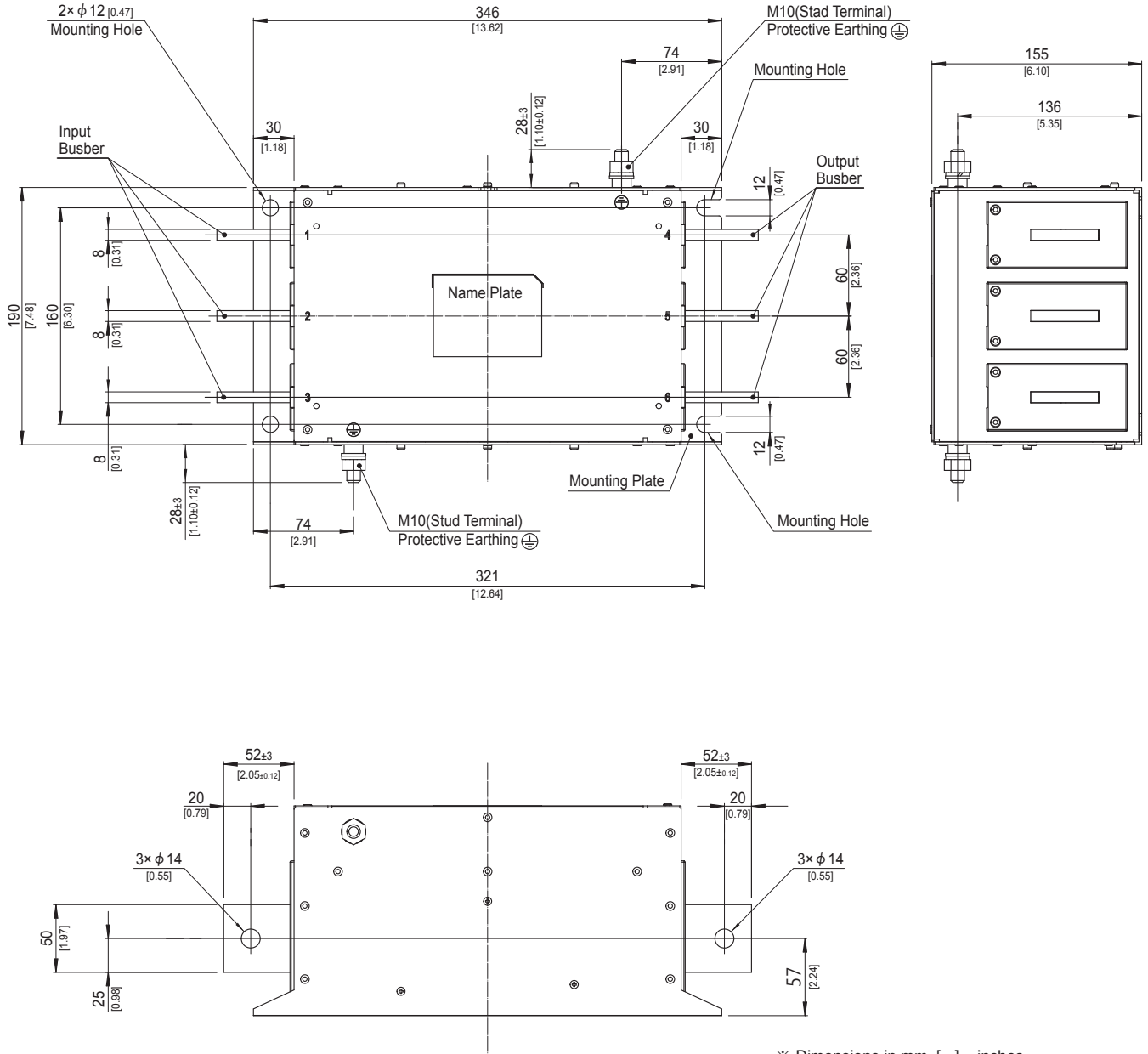

- ※ Dimensions in mm, [] = inches
- ※ Tolerance : ±1 [±0.04]
- ※ Weight : 11.5kg max
- ※ Mounting plate Material : Aluminum t = 2.0 [0.08]
- ※ Busbar Material : Copper (Unplated) t = 8.0 [0.31]
- ※ Protective Earthing(PE) screw tightening torque M10 : 14.2N · m max
- ※ Can not be mounted upside-down (Mounted the top surface)

TSC-400-000/TSC-600-000

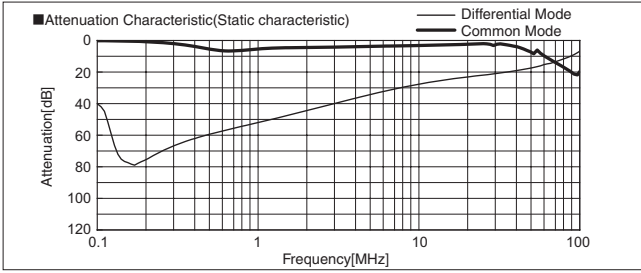

TSC-400-304/TSC-600-304

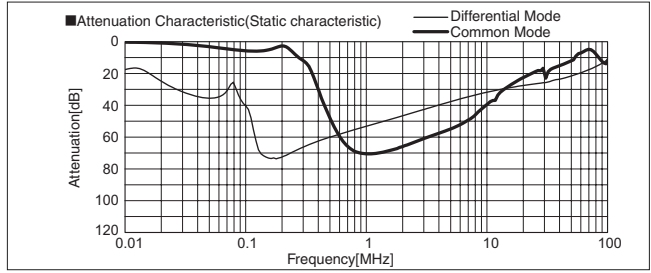

TSC-400-664/TSC-600-664

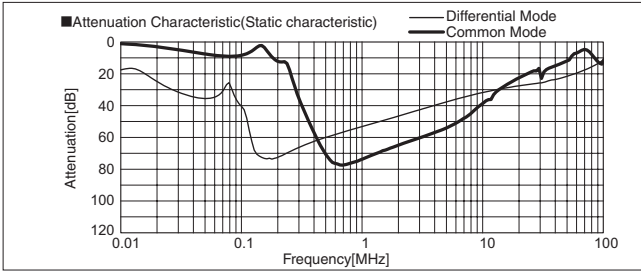

TSC-400-665/TSC-600-665

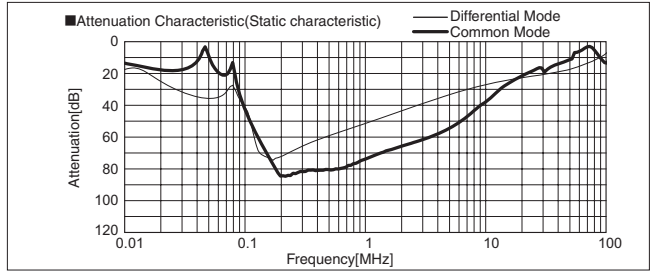

TSC-400-000-H/TSC-600-000-H

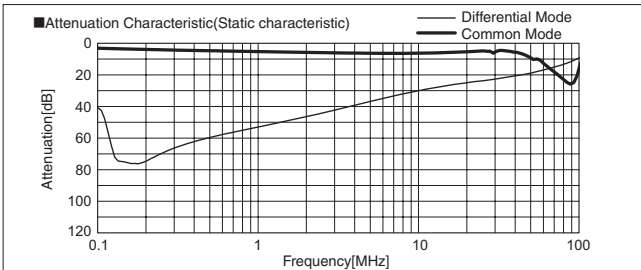

TSC-400-304-H/TSC-600-304-H

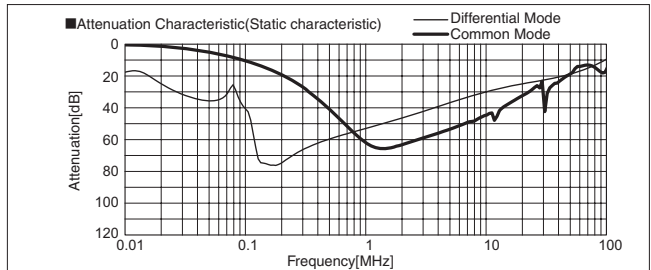

TSC-400-664-H/TSC-600-664-H

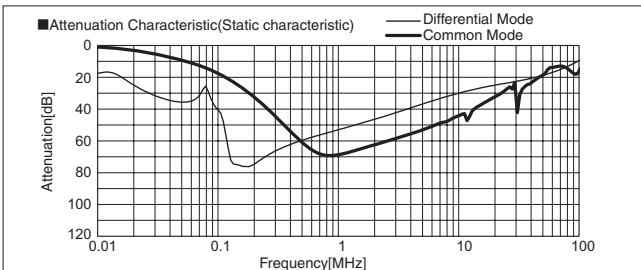

TSC-400-665-H/TSC-600-665-H

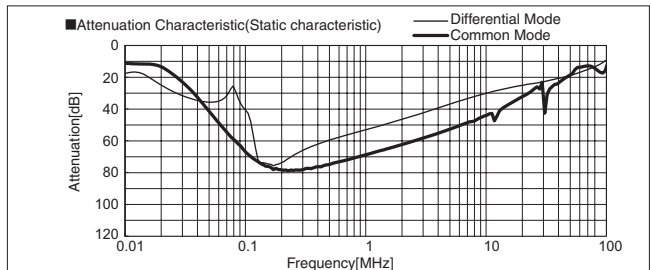

TSD-400-105/TSD-600-105

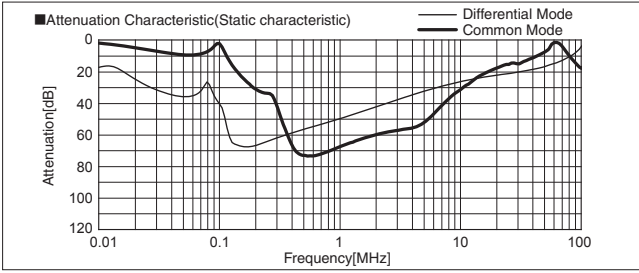

TSD-400-215/TSD-600-215

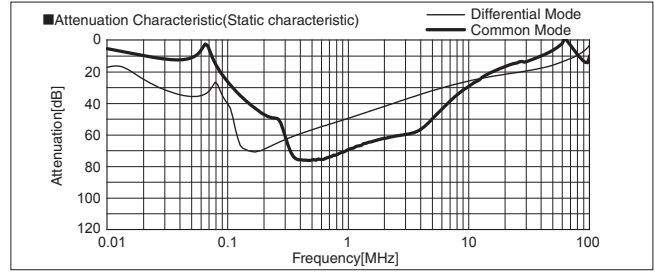

TSD-400-665/TSD-600-665

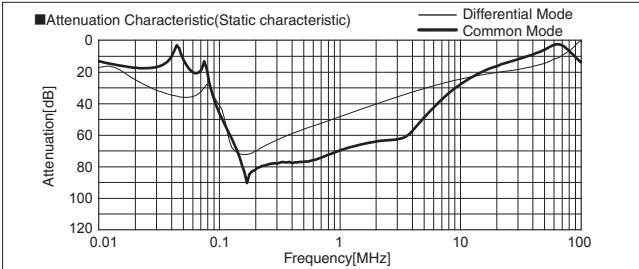

TSD-400-136/TSD-600-136

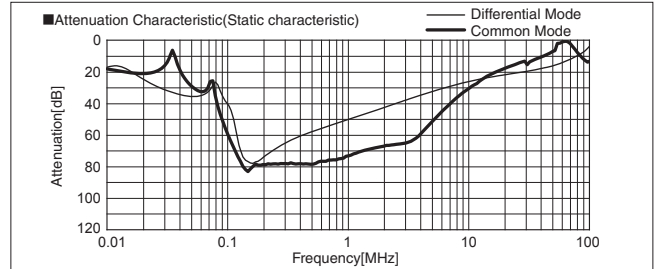

TSD-400-186/TSD-600-186

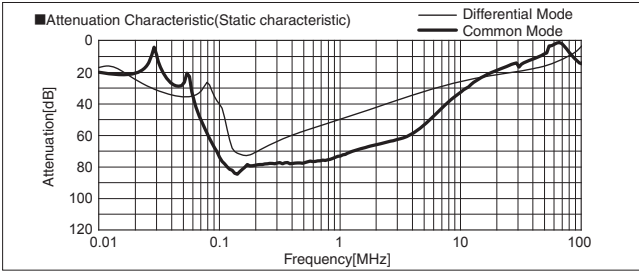

TSD-800-000/TSD-1000-000

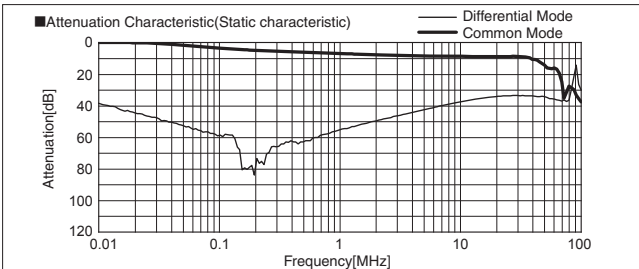

TSD-800-304/TSD-1000-304

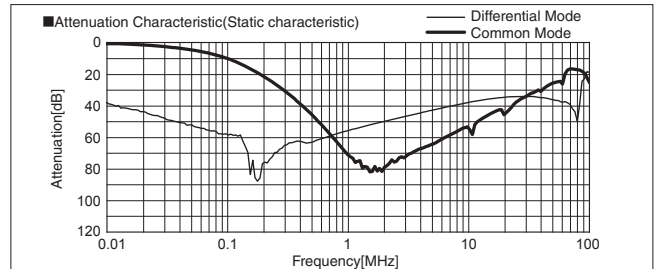

TSD-800-664/TSD-1000-664

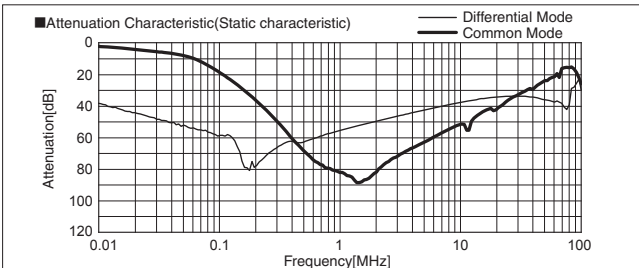

TSD-800-316/TSD-1000-316

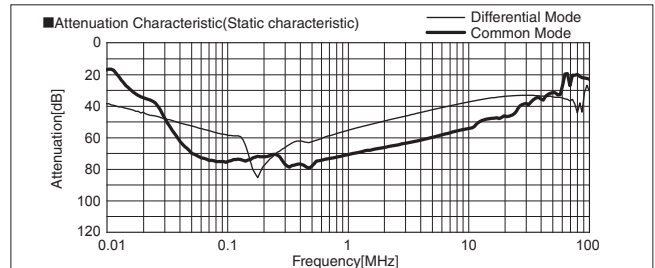

TSD-800-356/TSD-1000-356

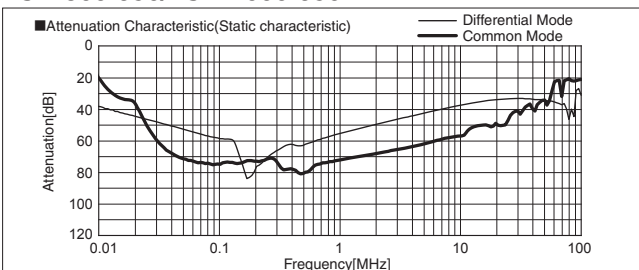

TSD-800-446/TSD-1000-446

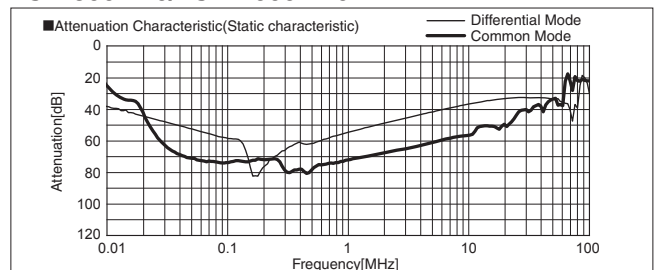

1 Busbar Connection Method

(1)TSC/TSD-400/600

When wiring an M10 terminal to the busbar, the external dimension of the crimp terminal is critical in maintaining isolation distance between insulating resin, chassis, and mounting screws. We therefore recommend that you use terminals of the dimensions shown in table 1.1.

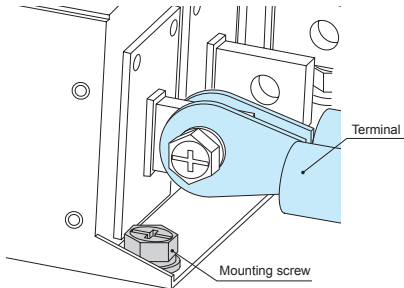

Fig.1.1 Busbar connection

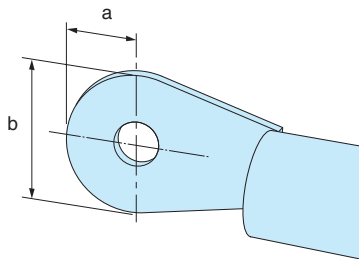

Fig.1.2 Terminals dimension

table.1.1 Selected conditions terminals dimension

Model Name	"a"Allowable dimension	"b"Allowable dimension
TSC/TSD series	19.5mm max	38.5mm max

(2)TSC/TSD-800/1000

For TSD (800A/1000A), bus bar connection is recommended. When making bus-bar connections, be careful to avoid interference with insulating resin parts and to maintain an insulation distance from the chassis and adjacent terminals.

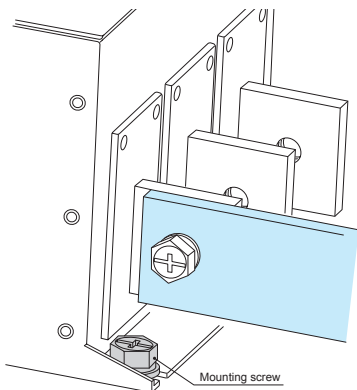

Fig.1.3 Busbar Connection

2 Notes on wiring and storage

■ Notes on wiring

Since the (copper) busbar has not been surface treated, surface oxidation may form a resistive layer between the contacts. We therefore recommend abrasion of all mating surfaces before, and wearing gloves during, all wiring work. Please be careful not to leave fingerprints.

■ Notes on storage

Please avoid storage in environments where copper corrosion is concerned. Storage under a normal temperature and humidity environment is recommended.

1 Method of connecting EMI/EMC Filter

(1) Single-phase

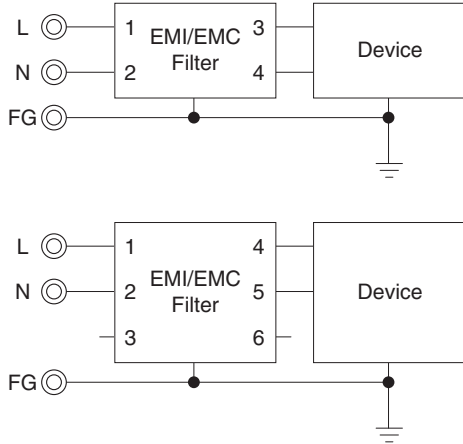

※Three-phase three-wire EMI/EMC filter is also available as a Single-phase input type.

(2) Three-phase three-wire

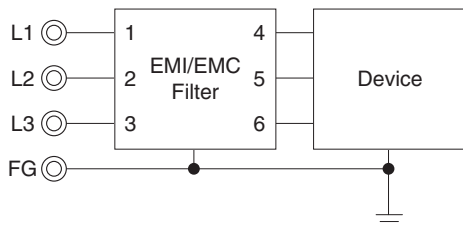

(3) Three-phase four-wire

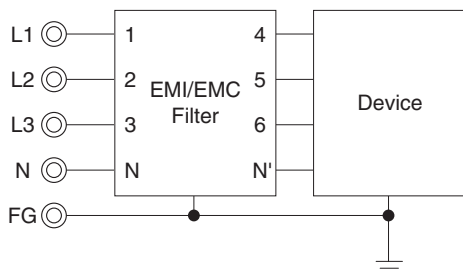

[Reference] Example of calculating input current calculation

Input voltage 400 [V]

Input capacity of the equipment 4000 [VA]

$$\text{Input current} = \frac{4000 \text{ [VA]}}{400 \text{ [V]} \times \sqrt{3}} = 5.8 \text{ [A]}$$

2 Caution when connecting EMI/EMC Filter

Please note the excessive temperature increase of EMI/EMC filter. Please contact us if judgement is difficult.

(1) Input voltage and frequency

Please use within the rated voltage (or maximum voltage) of each model.

Input frequency specification for AC input EMI/EMC filter is considered as commercial frequency (50/60Hz).

It should not be used under the following conditions.

- 1) Distorted input voltage waveform.
(Triangle wave, square wave etc.)
- 2) High input frequency (ex: 400Hz)

(2) Input current

Please use within the rated current of each model.

EMI/EMC filters have short term peak current capability. Therefore, it can flow ~40A or ten times of rated current, non-repeated, within a few ms such as inrush current of power supply etc.

However, it should not be used under the following conditions.

- 1) Long duration peak current.
- 2) Peak current or high-frequency current is continuously flowing.

(3) Connection to a general-purpose inverter (servo driver)

Please connect EMI/EMC filter to input side of inverter driver (servo driver).

It should not be used between the inverter (servo driver) and the motor.

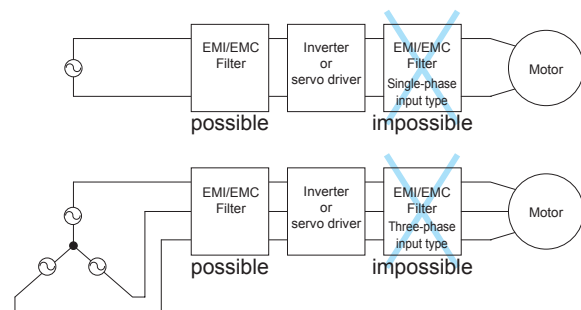

(4) Caution when a Three-phase four-wire system

When using a Three-phase three-wire system input, delta connection cannot be used.

When using the N and N' terminals of the EMI/EMC filter, the neutral line (N phase) must be connected.

If you have a Three-phase four-wire system with a Single-phase load connected between the neutral and each line, the neutral may carry considerably more current than the line current.

Please use this while ensuring that the input current does not exceed the rated current of the EMI/EMC filter.

3 Safety Considerations

- To apply for safety standard approval using this EMI/EMC Filter, the following conditions must be met.
- The unit must be used as a component of an end-use equipment.
- Protection earth terminal (PE) must be connected to safety ground of end-use equipment.

SNA series (1A,3A)

SNA -03 -223 -□

① ② ③ ④

- ① Model Name
- ② Rated Current
- ③ Line to ground capacitor code: See table 1.1.

table 1.1 Line to ground capacitor code

Code	Line to ground capacitor (nominal value)
000	Not Provided
223	22000pF

- ④ Options
- D: DIN rail installation type

* The dimensions change when the option is set. Refer to External view.

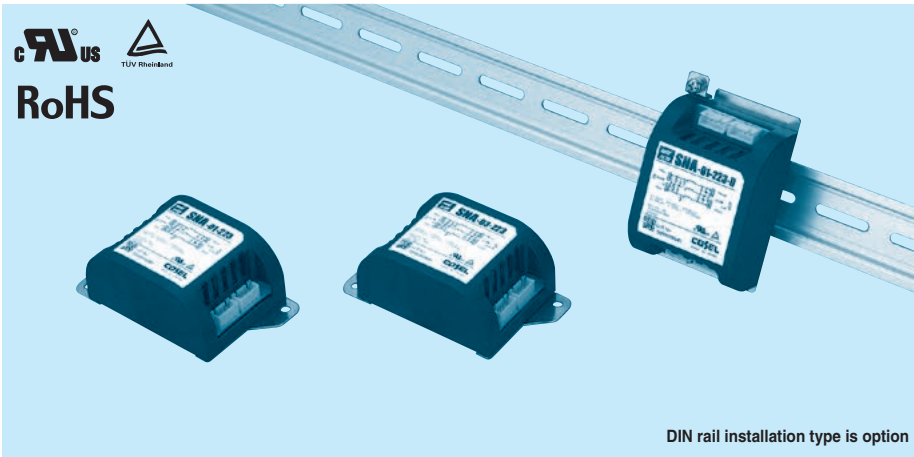

DIN rail installation type is option



Features of SNA series (1A and 3A)

Ripple noise attenuation type for switch mode power supplies(DC)

- ±50 VDC
- Best filter for switch mode power supplies of analog circuits (ex. power supply filter for an operational amplifier)

Specifications

No.	Items	SNA-01-223	SNA-03-223
		Interface: Connector	
1	Rated Voltage DC[V]	±50 (+Vin - COM-in, -Vin - COM-in)	
2	Rated Current DC[A]	1	3
3	Test Voltage (Terminal-Mounting Plate)	500 VAC (Cutoff Current = 100mA), 1minute at room temperature and humidity	
4	Isolation Resistance (Terminal-Mounting Plate)	500 VDC 50MΩ min at room temperature and humidity	
5	DC resistance	190mΩ max	90mΩ max
6	Operating temperature	-40 to +71°C (Refer to Derating Curve)	
7	Operating humidity	20 to 95%RH (Non condensing)	
8	Storage temperature/humidity	-40 to +75°C/20 to 95%RH (Non condensing)	
9	Vibration	10 to 55Hz, 19.6m/s ² (2G), 3min. Period, 1hour each X, Y and Z axis	
10	Impact	196.1m/s ² (20G), 11ms Once each X, Y and Z axis	
11	Safety agency approvals	UL60950-1, C-UL (CSA60950-1), EN62368-1	
12	Case size (without projection) /Weight	52 X 35 X 93 mm [2.05 X 1.38 X 3.66 inches] (W X H X D) /130g max (Option : -D refer to external view)	

Circuit Diagram

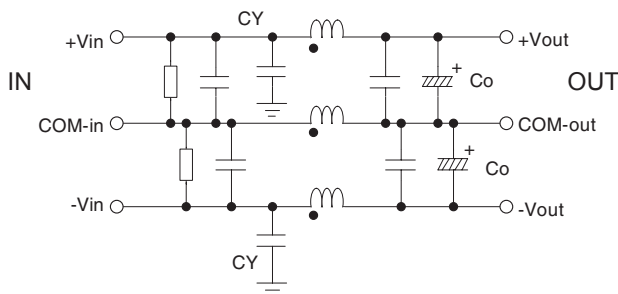

CY : Line to ground capacitor Co : Electrolytic capacitor : Mounting Plate

■ Expected life : 10 years

Derating Curve

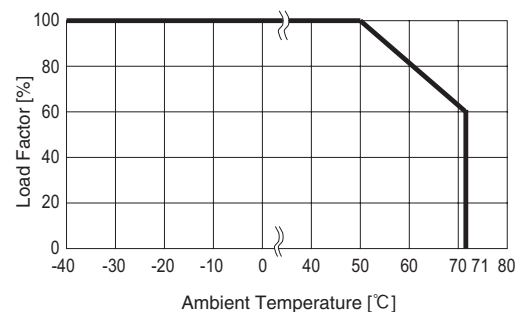

External view

Standard Type

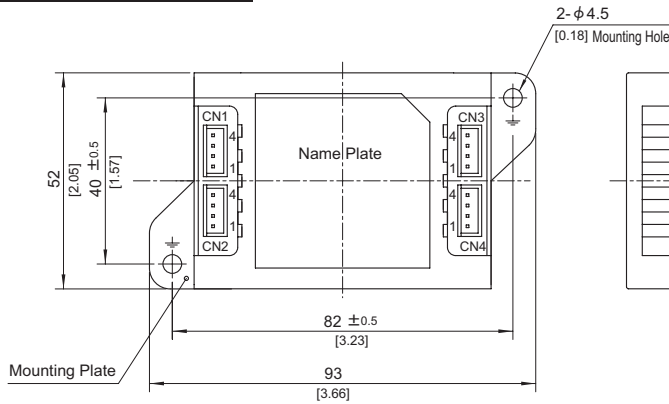

CN1	
Pin No.	Function
1,2	COM-in
3,4	+Vin

CN3	
Pin No.	Function
1,2	COM-out
3,4	+Vout

CN2	
Pin No.	Function
1,2	-Vin
3,4	COM-in

CN4	
Pin No.	Function
1,2	-Vout
3,4	COM-out

I/O Connector	Mating connector	Terminal
CN1-CN4	B4B-XH-AM	XHP-4
		Reel: SXH-001T-P0.6
		Bulk: BXH-001T-P0.6

(Mfr.: J.S.T)

Option harness : Refer to Instruction Manual 4

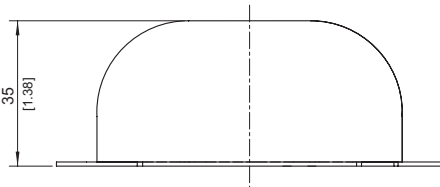

※ Tolerance : ±1 [±0.04]

※ Weight : 130g max

※ PCB Material /thickness : CEM3 /1.6mm [0.06 inches]

※ Mounting plate : Iron (surface finishing : nickel plating) t=1.0 [0.04]

※ Case : PBT

※ Dimensions in mm, []=inches

※ Keeping drawing current per pin below 2A for CN1 to CN4

DIN rail installation Type

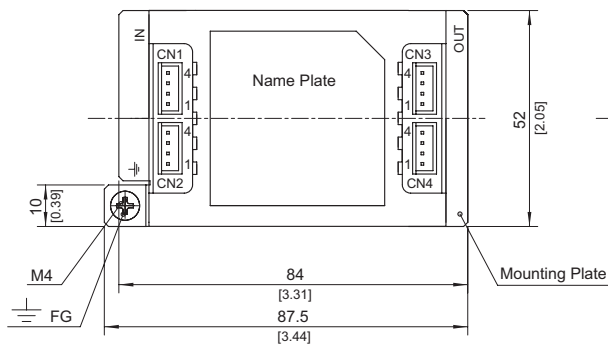

CN1	
Pin No.	Function
1,2	COM-in
3,4	+Vin

CN3	
Pin No.	Function
1,2	COM-out
3,4	+Vout

CN2	
Pin No.	Function
1,2	-Vin
3,4	COM-in

CN4	
Pin No.	Function
1,2	-Vout
3,4	COM-out

I/O Connector	Mating connector	Terminal
CN1-CN4	B4B-XH-AM	XHP-4
		Reel: SXH-001T-P0.6
		Bulk: BXH-001T-P0.6

(Mfr.: J.S.T)

Option harness : Refer to Instruction Manual 4

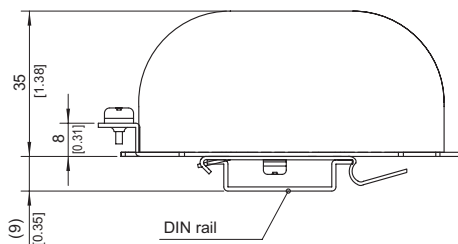

※ Tolerance : ±1 [±0.04]

※ Weight : 140g max

※ PCB Material /thickness : CEM3 /1.6mm [0.06 inches]

※ Mounting plate : Iron (surface finishing : nickel plating) t=1.0 [0.04]

※ Case : PBT

※ Dimensions in mm, []=inches

※ Keeping drawing current per pin below 2A for CN1 to CN4

■Note when installing the EMI/EMC Filter on a DIN rail.

When the EMI/EMC Filter is grounded through the DIN rail, the proper noise attenuation may not be achieved.

Be sure to connect the FG terminal of the EMI/EMC Filter body to the earth.

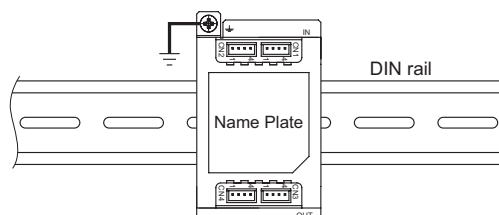

SNA series (6A)

SNA -06 -223 -□

① ② ③ ④

- ① Model Name
- ② Rated Current
- ③ Line to ground capacitor code: See table 1.1.

table 1.1 Line to ground capacitor code

Code	Line to ground capacitor (nominal value)
000	Not Provided
223	22000pF

- ④ Options
- D :DIN rail installation type
- T :Terminal block type
- DT :Terminal block and DIN rail type

* The dimensions change when the option is set. Refer to External view.

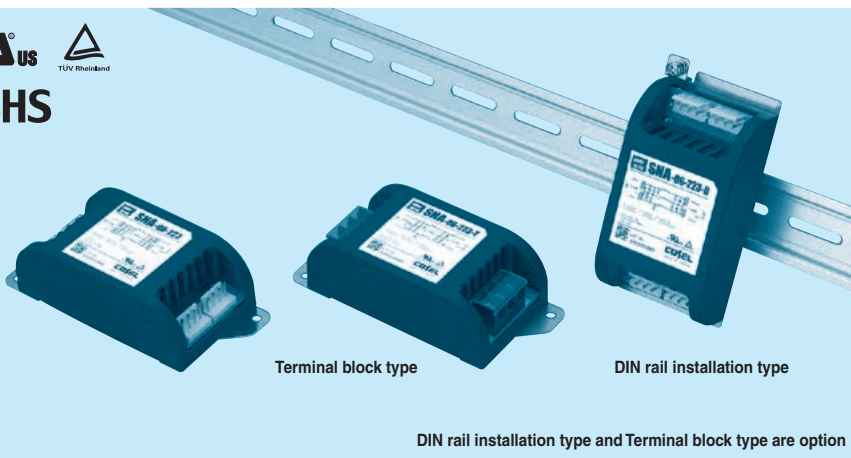

Terminal block type

DIN rail installation type

DIN rail installation type and Terminal block type are option

Features of SNA series (6A)

Ripple noise attenuation type for switch mode power supplies(DC)

· ±50 VDC

- Best filter for switch mode power supplies of analog circuits
- (ex. power supply filter for an operational amplifier)

Specifications

No.	Items	SNA-06-223
		Interface:Connector
1	Rated Voltage DC[V]	±50 (+Vin - COM-in, -Vin - COM-in)
2	Rated Current DC[A]	6
3	Test Voltage (Terminal-Mounting Plate)	500 VAC (Cutoff Current = 100mA), 1minute at room temperature and humidity
4	Isolation Resistance (Terminal-Mounting Plate)	500 VDC 50MΩ min at room temperature and humidity
5	DC resistance	50mΩ max
6	Operating temperature	-40 to +71°C (Refer to Derating Curve)
7	Operating humidity	20 to 95%RH (Non condensing)
8	Storage temperature/humidity	-40 to +75°C/20 to 95%RH (Non condensing)
9	Vibration	10 to 55Hz, 19.6m/s ² (2G), 3min. Period, 1hour each X, Y and Z axis
10	Impact	196.1m/s ² (20G), 11ms Once each X, Y and Z axis
11	Safety agency approvals	UL60950-1, C-UL (CSA60950-1), EN62368-1
12	Case size (without projection) /Weight	52 X 35 X 117 mm [2.05 X 1.38 X 4.61 inches] (W X H X D) /150g max (Option : -D, -T, -DT refer to external view)

Circuit Diagram

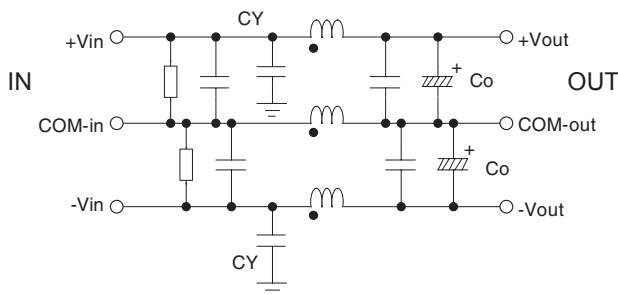

CY : Line to ground capacitor Co : Electrolytic capacitor : Mounting Plate

■ Expected life : 10 years

Derating Curve

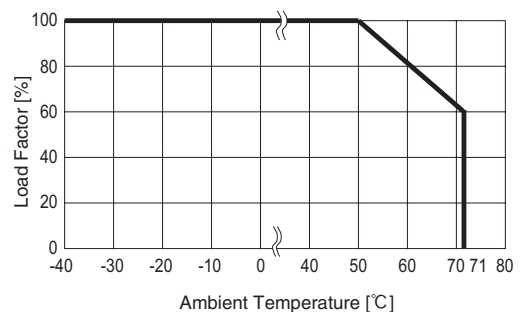

External view

Standard Type

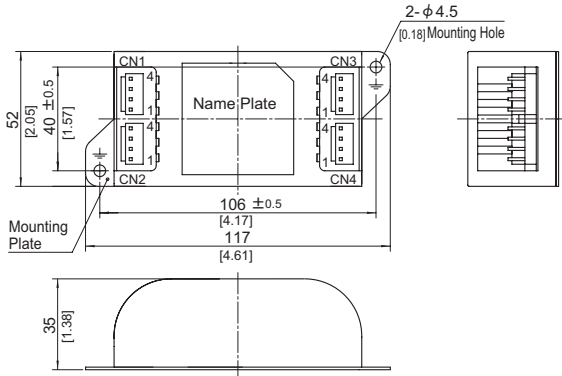

- ※ Tolerance : ± 1 [± 0.04]
- ※ Weight : 150g max
- ※ PCB Material /thickness : CEM3 /1.6mm [0.06 inches]
- ※ Mounting plate : Iron (surface finishing : nickel plating) $t=1.0$ [0.04]
- ※ Case : PBT
- ※ Dimensions in mm, []=inches
- ※ Keeping drawing current per pin below 5A for CN1 to CN4

CN1		CN3	
Pin No.	Function	Pin No.	Function
1,2	COM-in	1,2	COM-out
3,4	+Vin	3,4	+Vout

CN2		CN4	
Pin No.	Function	Pin No.	Function
1,2	-Vin	1,2	-Vout
3,4	COM-in	3,4	COM-out

I/O Connector	Mating connector	Terminal
CN1-CN4	B4P-VH VHR-4N	Reel:SVH-21T-P1.1 Bulk:BVH-21T-P1.1

(Mfr:J.S.T)

Option harness : Refer to Instruction Manual 4

Terminal block Type

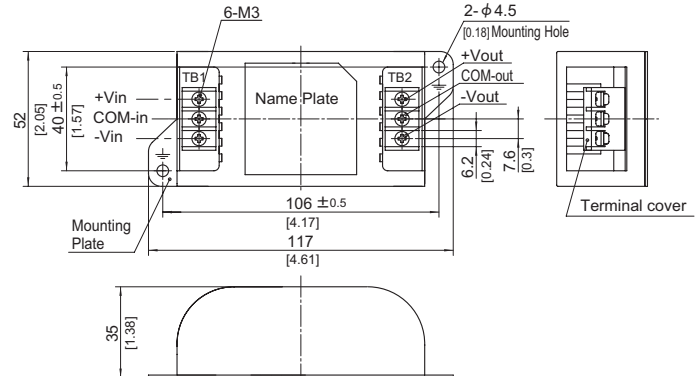

- ※ Tolerance : ± 1 [± 0.04]
- ※ Weight : 160g max
- ※ PCB Material /thickness : CEM3 /1.6mm [0.06 inches]
- ※ Mounting plate : Iron (surface finishing : nickel plating) $t=1.0$ [0.04]
- ※ Case : PBT
- ※ Dimensions in mm, []=inches
- ※ Terminal block screw tightening torque M3:0.8N · m (8.5kgf · cm) max

DIN rail installation Type

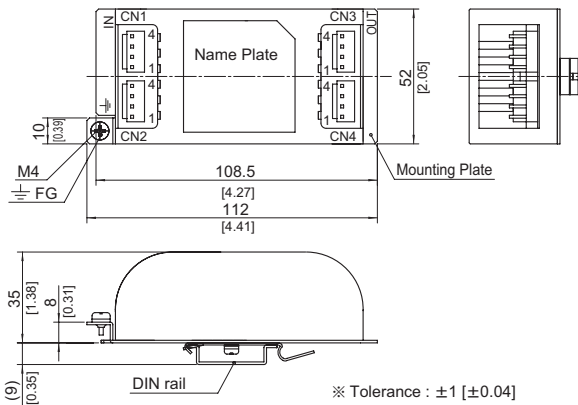

- ※ Tolerance : ± 1 [± 0.04]
- ※ Weight : 160g max
- ※ PCB Material /thickness : CEM3 / 1.6mm [0.06 inches]
- ※ Mounting plate : Iron (surface finishing : nickel plating) $t=1.0$ [0.04]
- ※ Case : PBT
- ※ Dimensions in mm, []=inches
- ※ Keeping drawing current per pin below 5A for CN1 to CN4

CN1		CN3	
Pin No.	Function	Pin No.	Function
1,2	COM-in	1,2	COM-out
3,4	+Vin	3,4	+Vout

CN2		CN4	
Pin No.	Function	Pin No.	Function
1,2	-Vin	1,2	-Vout
3,4	COM-in	3,4	COM-out

I/O Connector	Mating connector	Terminal
CN1-CN4	B4P-VH VHR-4N	Reel:SVH-21T-P1.1 Bulk:BVH-21T-P1.1

(Mfr:J.S.T)

Option harness : Refer to Instruction Manual 4

Terminal block type+DIN rail installation Type

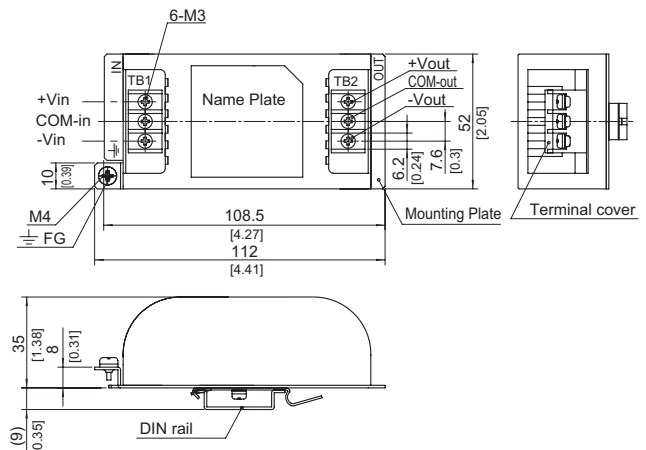

- ※ Tolerance : ± 1 [± 0.04]
- ※ Weight : 170g max
- ※ PCB Material /thickness : CEM3 /1.6mm [0.06 inches]
- ※ Mounting plate : Iron (surface finishing : nickel plating) $t=1.0$ [0.04]
- ※ Case : PBT
- ※ Dimensions in mm, []=inches
- ※ Terminal block screw tightening torque M3:0.8N · m (8.5kgf · cm) max

■Note when installing the EMI/EMC Filter on a DIN rail.

When the EMI/EMC Filter is grounded through the DIN rail, the proper noise attenuation may not be achieved.

Be sure to connect the FG terminal of the EMI/EMC Filter body to the earth.

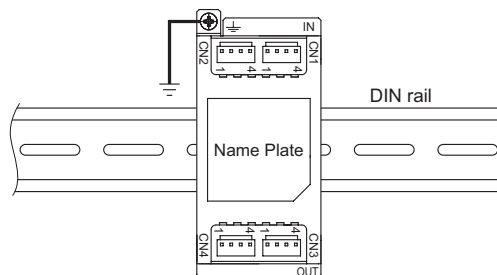

SNR series (10A)

SNR -10 -223 -□

① ② ③ ④

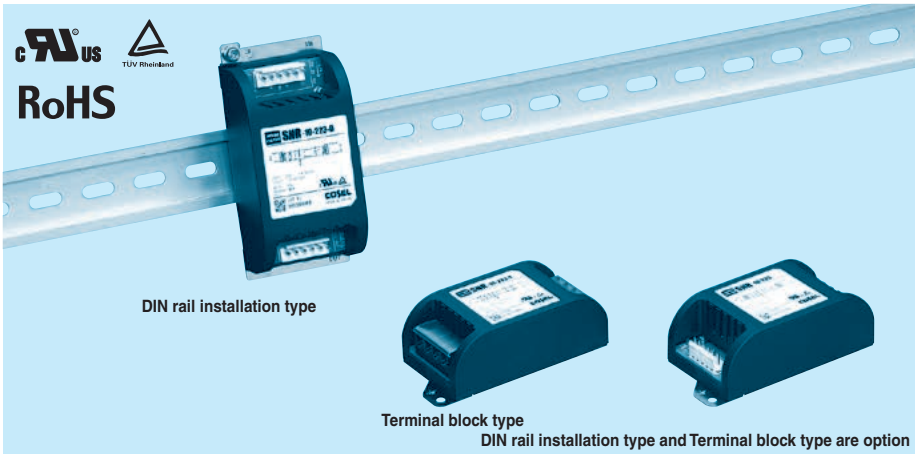

- ① Model Name
- ② Rated Current
- ③ Line to ground capacitor code: See table 1.1.

table 1.1 Line to ground capacitor code

Code	Line to ground capacitor (nominal value)
000	Not Provided
223	22000pF

- ④ Options
- D :DIN rail installation type
- T :Terminal block type
- DT :Terminal block and DIN rail type

* The dimensions change when the option is set. Refer to External view.

Features of SNR series (10A)

Ripple noise attenuation type for switch mode power supplies(DC)

· 50 VDC

· Best filter for switch mode power supplies of analog circuits

Specifications

No.	Items	SNR-10-223	
		Interface:Connector	
1	Rated Voltage DC[V]	50	
2	Rated Current DC[A]	*1	10 (Peak 20)
3	Test Voltage (Terminal-Mounting Plate)	500 VAC (Cutoff Current = 100mA), 1minute at room temperature and humidity	
4	Isolation Resistance (Terminal-Mounting Plate)	500 VDC 50MΩ min at room temperature and humidity	
5	DC resistance	20mΩ max	
6	Operating temperature	-40 to +71°C (Refer to Derating Curve)	
7	Operating humidity	20 to 95%RH (Non condensing)	
8	Storage temperature/humidity	-40 to +75°C/20 to 95%RH (Non condensing)	
9	Vibration	10 to 55Hz, 19.6m/s ² (2G), 3min. Period, 1hour each X, Y and Z axis	
10	Impact	196.1m/s ² (20G), 11ms Once each X, Y and Z axis	
11	Safety agency approvals	UL60950-1, C-UL (CSA60950-1), EN62368-1	
12	Case size (without projection) /Weight	52 X 35 X 117 mm [2.05 X 1.38 X 4.61 inches] (WXHXD) /140g max (Option : -D, -T, -DT refer to external view)	

*1 Peak current for 10 sec. And Duty 35% max, refer to Instruction Manual 5. In detail.

Circuit Diagram

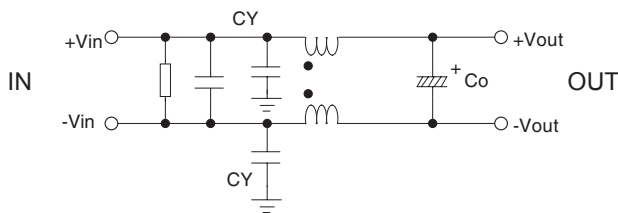

CY : Line to ground capacitor Co : Electrolytic capacitor $\frac{\square}{\square}$: Mounting Plate

■ Expected life : 10 years

Derating Curve

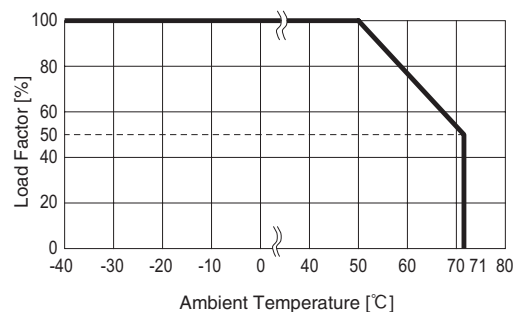

External view

Standard Type

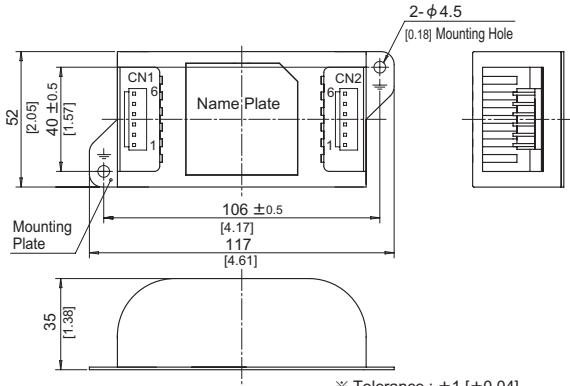

- ※ Tolerance : ± 1 [± 0.04]
- ※ Weight : 140g max
- ※ PCB Material /thickness : CEM3 /1.6mm [0.06 inches]
- ※ Mounting plate : Iron (surface finishing : nickel plating) $t=1.0$ [0.04]
- ※ Case : PBT
- ※ Dimensions in mm, []=inches
- ※ Keeping drawing current per pin below 5A (7A at peak current) for CN1 to CN2

CN1		CN2	
Pin No.	Function	Pin No.	Function
1,2,3	-Vin	1,2,3	-Vout
4,5,6	+Vin	4,5,6	+Vout

I/O Connector	Mating connector	Terminal
CN1,CN2	B6P-VH	VHR-6N
		Reel:SVH-21T-P1.1
		Bulk:BVH-21T-P1.1

(Mfr:J.S.T)

Option harness : Refer to Instruction Manual 4

Terminal block Type

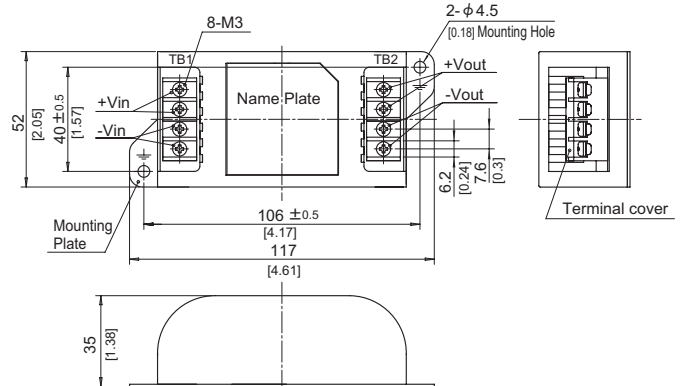

- ※ Tolerance : ± 1 [± 0.04]
- ※ Weight : 150g max
- ※ PCB Material /thickness : CEM3 /1.6mm [0.06 inches]
- ※ Mounting plate : Iron (surface finishing : nickel plating) $t=1.0$ [0.04]
- ※ Case : PBT
- ※ Dimensions in mm, []=inches
- ※ Terminal block screw tightening torque $M3:0.8N \cdot m$ (8.5kgf \cdot cm) max
- ※ Keeping drawing current per pin below 8A (10A at peak current) for TB1 to TB2

DIN rail installation Type

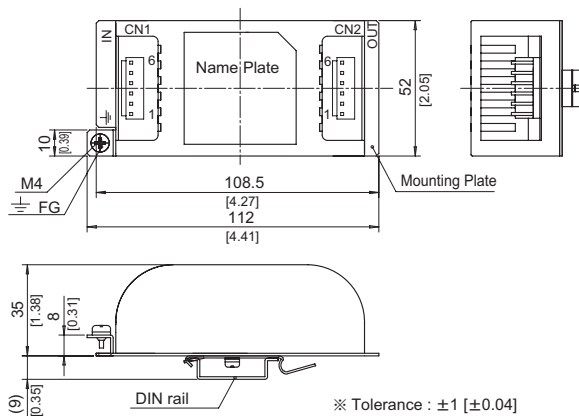

- ※ Tolerance : ± 1 [± 0.04]
- ※ Weight : 150g max
- ※ PCB Material /thickness : CEM3 / 1.6mm [0.06 inches]
- ※ Mounting plate : Iron (surface finishing : nickel plating) $t=1.0$ [0.04]
- ※ Case : PBT
- ※ Dimensions in mm, []=inches
- ※ Keeping drawing current per pin below 5A (7A at peak current) for CN1 to CN2

CN1		CN2	
Pin No.	Function	Pin No.	Function
1,2,3	-Vin	1,2,3	-Vout
4,5,6	+Vin	4,5,6	+Vout

I/O Connector	Mating connector	Terminal
CN1,CN2	B6P-VH	VHR-6N
		Reel:SVH-21T-P1.1
		Bulk:BVH-21T-P1.1

(Mfr:J.S.T)

Option harness : Refer to Instruction Manual 4

Terminal block type+DIN rail installation Type

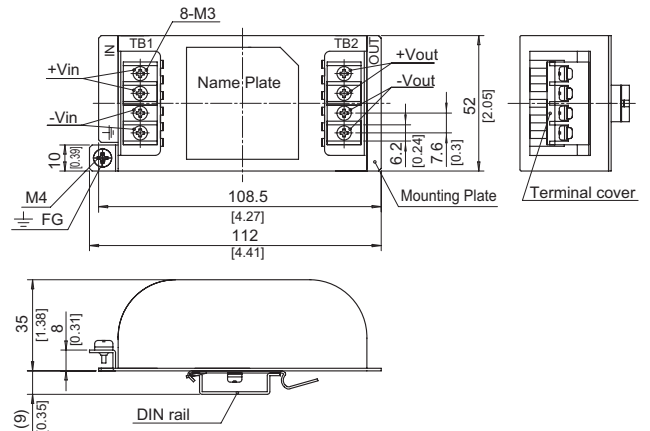

- ※ Tolerance : ± 1 [± 0.04]
- ※ Weight : 160g max
- ※ PCB Material /thickness : CEM3 /1.6mm [0.06 inches]
- ※ Mounting plate : Iron (surface finishing : nickel plating) $t=1.0$ [0.04]
- ※ Case : PBT
- ※ Dimensions in mm, []=inches
- ※ Terminal block screw tightening torque $M3:0.8N \cdot m$ (8.5kgf \cdot cm) max
- ※ Keeping drawing current per pin below 8A (10A at peak current) for TB1 to TB2

■Note when installing the EM/EMC Filter on a DIN rail.

When the EM/EMC Filter is grounded through the DIN rail, the proper noise attenuation may not be achieved.

Be sure to connect the FG terminal of the EM/EMC Filter body to the earth.

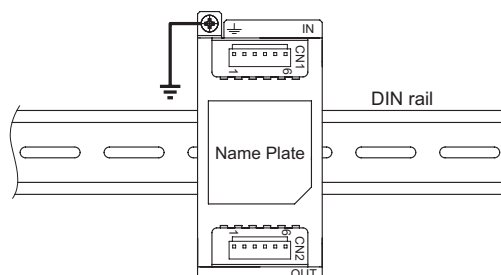

SNA-01-223

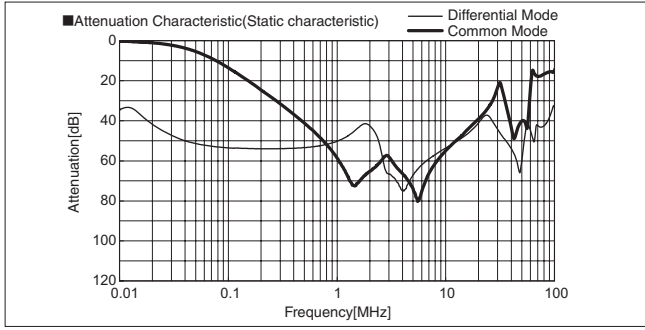

SNA-03-223

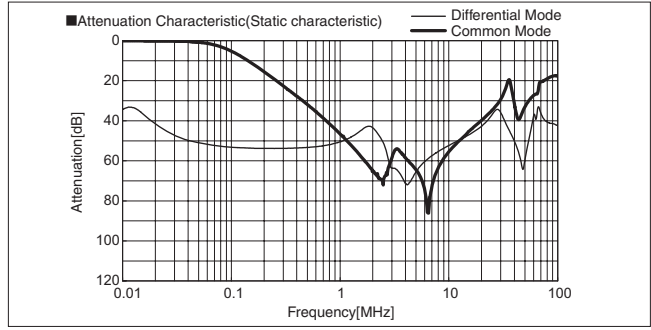

SNA-06-223

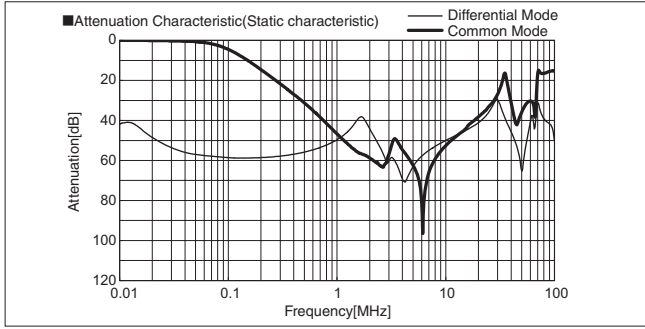

SNR-10-223

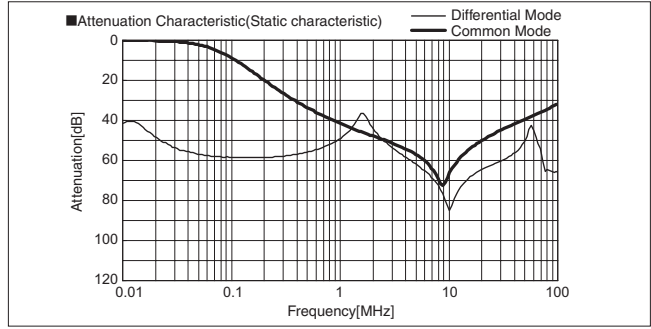

※ This product only reduces ripple noise of the switch mode power supply. It cannot be used effectively to reduce ripple noise at line frequency.

■ Example of attenuation output noise.

LCA10S-12

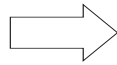
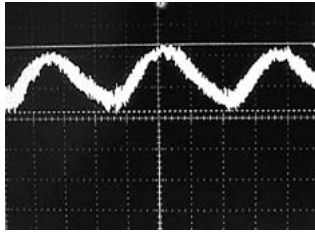

LCA10S-12+SNA-01-223

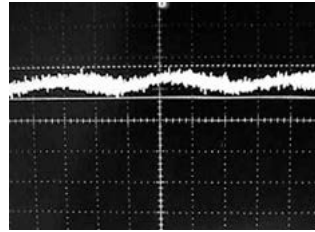

(Room temp, Room Humi)
BW:500MHz
LCA10S-12
12V 0.9A

LCA30S-12

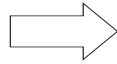
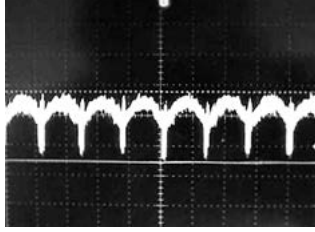

LCA30S-12+SNA-03-223

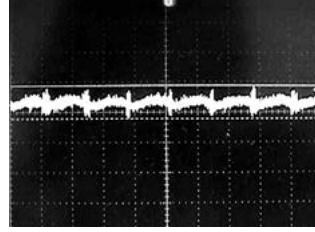

(Room temp, Room Humi)
BW:500MHz
LCA30S-12
12V 2.5A

LCA50S-12

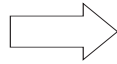
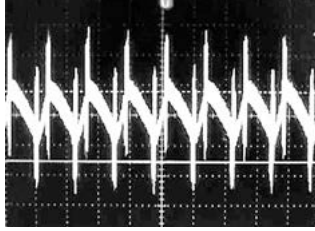

LCA50S-12+SNA-06-223

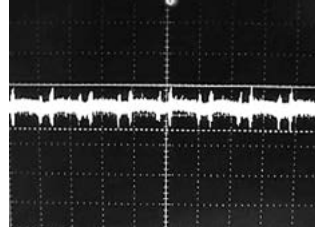

(Room temp, Room Humi)
BW:500MHz
LCA50S-12
12V 4.3A

LEP240F-24

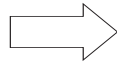
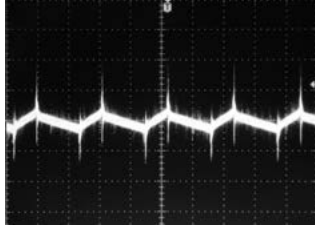

LEP240F-24+SNR-10-223

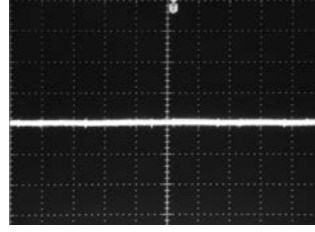

(Room temp, Room Humi)
BW:500MHz
LEP240F-24
24V 10A

※ Measured by differential probe (KEISOKU-GIKEN:DP-100).

1 Wiring to Input/Output terminals

■ This filter uses polarized components (electrolytic capacitor), The filter will break if reverse voltage is applied to the input/output terminals. Please exercise caution when wiring.

2 Application examples

■ Power supply for an operational amplifier.

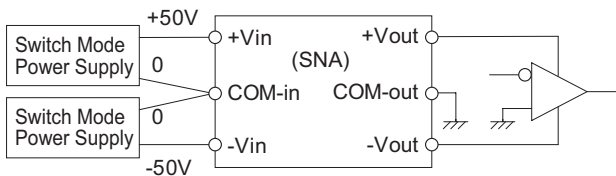

■ Single output power supply.

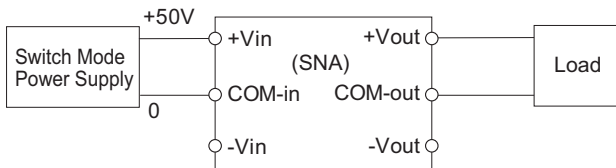

3 Safety Considerations

■ To apply for safety standard approval using this EMI/EMC Filter, the following conditions must be met.

- The unit must be used as a component of an end-use equipment.
- The unit must be used in the secondary circuit that is insulated from the primary circuit through double or reinforced insulation.
- The mounting plate (FG) must be connected to safety ground of end-use equipment.

4 Optional Parts

■ The harness for Input/Output of EMI/EMC Filter is available.

Model	Harness model
SNA-01	H-OU-8
SNA-03	H-OU-8
SNA-06	H-OU-9
SNR-10	H-OU-18

※ The same harness model applies to both input and output.

※ Sold in units of 1 piece.

5 Peak current (SNR)

■ Peak current is possible to draw as below.

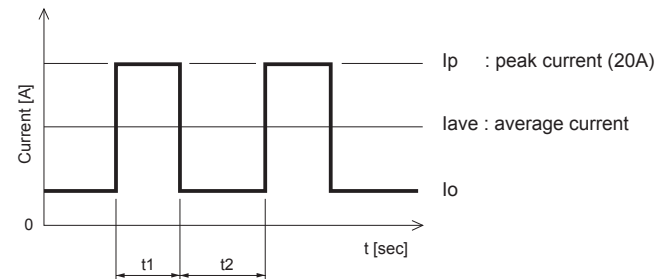

$$t1 \leq 10 \text{ [sec]}, I_{ave} = \frac{I_p \cdot t1 + I_o \cdot t2}{t1 + t2} \leq \text{rated current}$$

$$\frac{t1}{t1 + t2} \leq \text{Duty}$$

Duty is depended on peak current, refer to below chart.

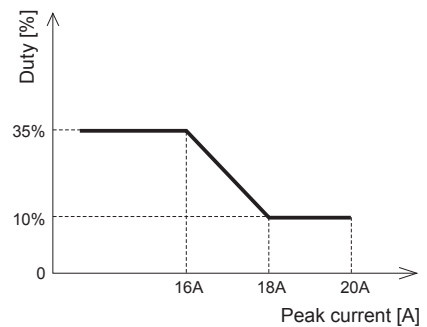

(1) Attenuation Characteristic(Static characteristic)

※ Attenuation = $20 \log(U_{b1}/U_{b2})$ [dB]
 U_{b1} : Voltage in state without filter (Reference Connection)
 U_{b2} : Voltage in state where the filter is added (Test Connection)
 ※ N.A. : Network analyzer

■ Object product : Single-phase input type (Differential mode)



■ Object product : Single-phase input type (Common mode)

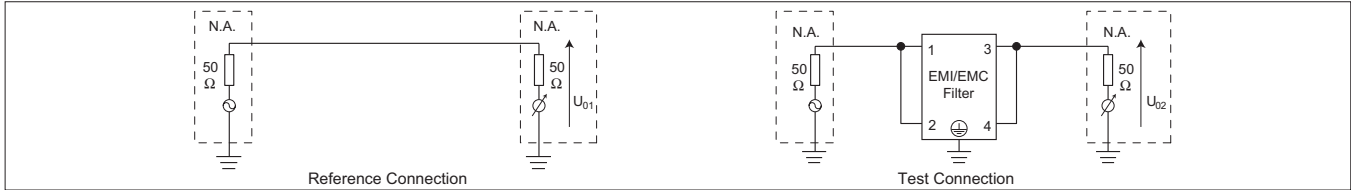

■ Object product : Three-phase three-wire system (Differential mode)

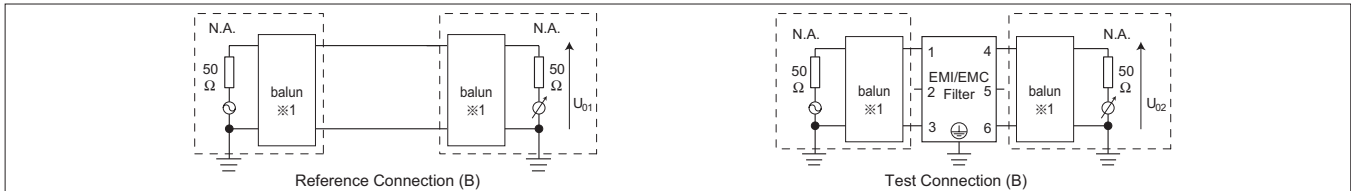
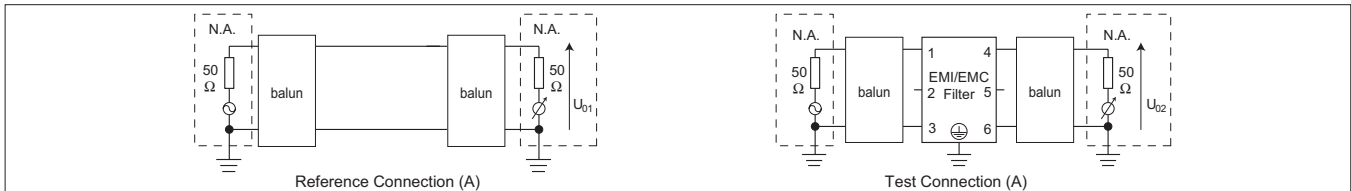

※ Measured with the above test circuit (A) or (B)
 ※1 Equilibrium measurement with mixed-mode S-parameters in the instrument

■ Object product : Three-phase three-wire system (Common mode)

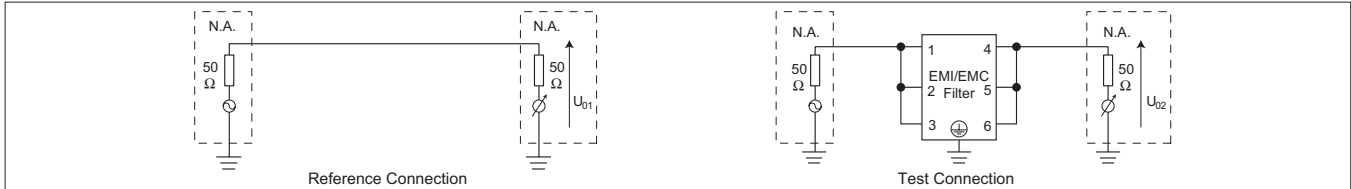

■ Object product : Three-phase four-wire system (Differential mode)

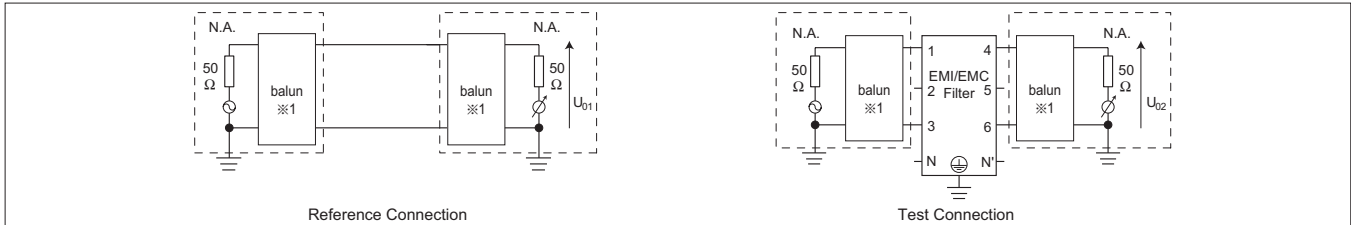

※1 Equilibrium measurement with mixed-mode S-parameters in the instrument

■ Object product : Three-phase four-wire system (Common mode)

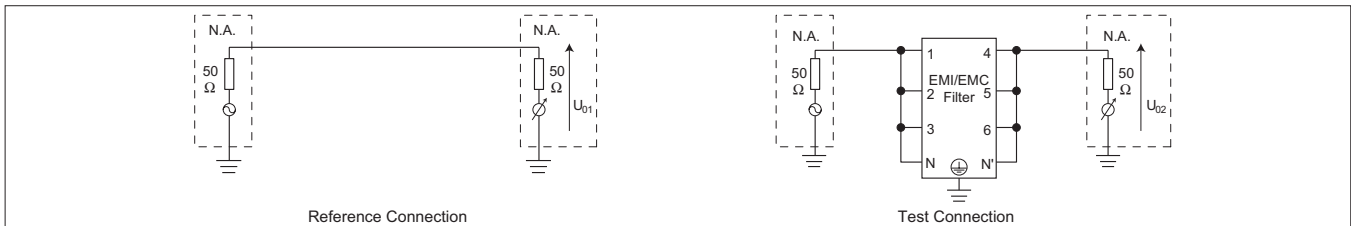

※ Attenuation = $20 \log(U_{01}/U_{02})$ [dB]
 U_{01} : Voltage in state without filter (Reference Connection)
 U_{02} : Voltage in state where the filter is added (Test Connection)
 ※ N.A. : Network analyzer

■ Object product : DC input type (Differential mode)

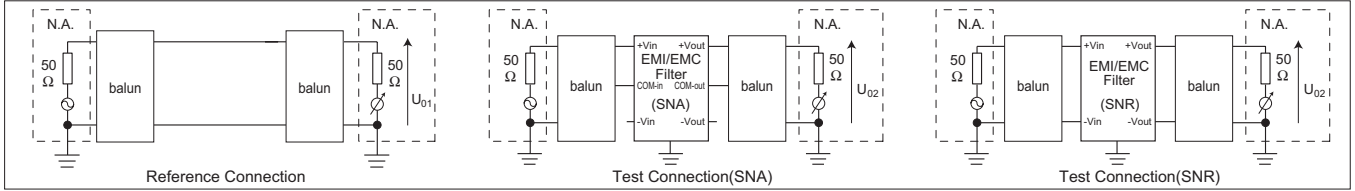

■ Object product : DC input type (Common mode)

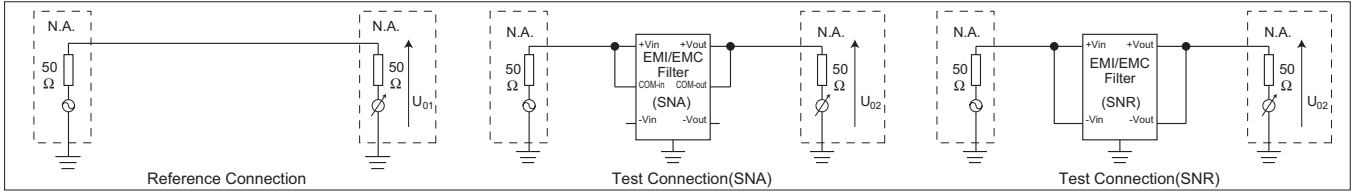

(2) Pulse Attenuation Characteristic

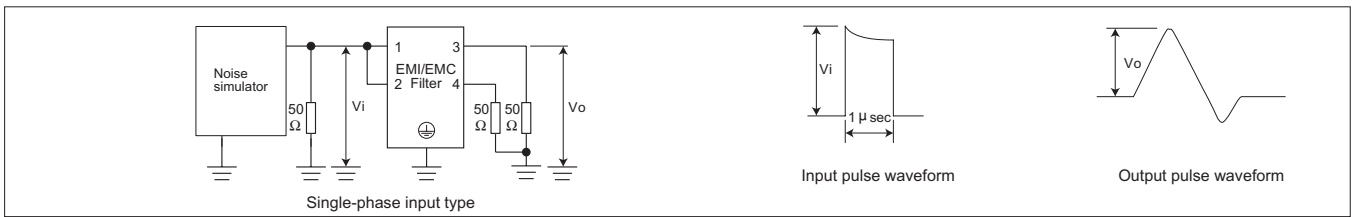



□ Head Office

COSEL CO., LTD.

1-6-43 Kamiakae-machi, Toyama 930-0816, Japan

Phone +81-76-432-8152

E-mail sales@cosel.co.jp

U R L <https://www.cosel.com/en/>

□ Worldwide Sales / Support Network

[AMERICA]

COSEL U.S.A., INC.

Phone (Free) +1-408-980-5144

E-mail sales@coselusa.com

U R L <https://coselusa.com>

《Engineering and Technical Support》

E-mail techsupport@coselusa.com

[EUROPE]

COSEL EUROPE GmbH

Phone +49-69-95 00 79-0

E-mail sales@coselurope.eu

U R L <https://www.coseleurope.eu>

《Engineering and Technical Support》

E-mail techsupport@coselurope.eu

[ASIA]

COSEL ASIA LTD.

Phone +852-2305-2712

E-mail sales@coselasia.com

U R L <https://www.coselasia.com>

COSEL (SHANGHAI) ELECTRONICS CO., LTD.

Phone +86-21-6440-0381

E-mail sales@coselasia.cn

U R L <https://www.coselasia.cn>