

1	Functions	HFA-9
	1.1 Input Voltage Range	HFA-9
	1.2 Inrush Current Limiting	HFA-9
	1.3 Overcurrent Protection	HFA-9
	1.4 Overvoltage Protection	HFA-9
	1.5 Thermal Protection	HFA-9
	1.6 Output Voltage Adjustment Range	HFA-9
	1.7 Output Ripple and Ripple Noise	HFA-10
	1.8 Remote ON/OFF	HFA-10
	1.9 Remote Sensing	HFA-10
	1.10 Isolation	HFA-11
	1.11 Signal Output (LED/Warning/Alarm)	HFA-11
	1.12 Sequence Diagram	HFA-11
2	Series/Parallel Operation	HFA-12
	2.1 Series Operation	HFA-12
	2.2 Parallel Operation/Master-slave Operation	HFA-12
	2.3 N+1 Parallel Redundancy Operation	HFA-12
3	Life Expectancy and Warranty	HFA-13
4	Others	HFA-13
	4.1 Auxiliary Power (AUX)	HFA-13
	4.2 External Output Capacitors	HFA-13
	4.3 External Component (EMI/EMC Filter)	HFA-14
	4.4 Grounding	HFA-14
	4.5 Variable Speed Fan	HFA-14
5	Options	HFA-14
	5.1 Outline of Options	HFA-14

1 Functions

1.1 Input Voltage Range

- The input voltage range is 180-528VAC (three-phase).
- In cases that conform with safety standard, input voltage range is 200-480VAC (50/60Hz).
- The input phase line shall not be specified, it can be connected to any input terminal.
- In the case of three-phase four-wire system, connect three wires to input terminal (L1, L2, L3), except neutral wire.

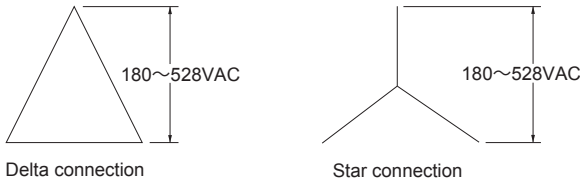

- If the wrong input or single phase input is applied, the unit will not operate properly and/or may be damaged. If the input is the square wave like a UPS and inverters, please contact us.
- A unit complies with IEC61000-6-2 and SEMI F47 input voltage dip.

1.2 Inrush Current Limiting

- A unit has the built-in inrush current limiting circuit.
- If a switch needs to be installed on the input side, please select one that can withstand an input inrush current.
- Thermistor, IGBT and Relay are used in the inrush current limiting circuit. When AC input is removed and reapplied in a short period of time, the inrush current limiting circuit might not work. Please have enough intervals so that a power supply cools down before being turned on. And, the primary and the secondary inrush current will flow.

1.3 Overcurrent Protection

- A unit has the built-in overcurrent protection circuit which will activate at over 105% of the rated current. A unit automatically recovers when a fault condition is removed. Please do not use a unit in short circuit and/or under an overcurrent condition.
- Hiccup mode
When the overcurrent protection circuit is activated and the output voltage drops to a certain extent, the output becomes hiccup mode so that the average current will also decrease.

1.4 Overvoltage Protection

- When output voltage is increased and the overvoltage protection activates, the output voltage is shut down.
- Output voltage recovers from overvoltage protection by shutting down the input voltage and waiting more than 3 minutes then turning on AC input again, or turning off the output voltage by remote control.

Note :

- Please avoid applying a voltage exceeding the rated voltage to an output terminal. It may cause a power supply to malfunction or fail. If it cannot be avoided like motor load and so on, please contact us.

1.5 Thermal Protection

- A unit has the built-in thermal protection circuit.
When a current and a temperature continue to exceed the values determined by the derating curve, the thermal protection circuit may be activated and shut down the output.
- The output voltage recovers from the thermal protection by the following actions.
 - 1) AC input is removed and reapplied after removing the overheat cause and cooling a unit.
 - 2) The output is turned off by the remote ON/OFF function and turned on after removing the overheat cause and cooling a unit.

1.6 Output Voltage Adjustment Range

- To increase an output voltage, turn the built-in potentiometer clockwise.
To decrease the output voltage, turn it counterclockwise.
- The output voltage can be adjusted by changing the voltage between the terminal VTRM and the terminal COM on CN1/CN2. The output voltage can be decreased by drawing a current from the VTRM terminal. In this case, the output voltage value can be calculated by the formula ① below. ① is the formula for estimating. If the accurate number is necessary, please contact us. Please do not apply +5V or more or negative voltage between VTRM and COM.
Please contact us for the detail of the output adjustment if needed.

$$\text{Output voltage} = \frac{\text{The voltage between VTRM and COM}}{2.5 [V]} \times \text{rated output voltage} \cdots \textcircled{1}$$

Table 1.1 Output voltage adjustment range

Model	Output voltage adjustment range by VTRM terminal [V]
HFA3500TF-48	24.0 to 55.2
HFA3500TF-65	32.5 to 74.7
HFA3500TF-90	45.00 to 105.00
HFA3500TF-130	65.00 to 170.00
HFA3500TF-200	100.00 to 260.00
HFA3500TF-300	200.00 to 400.00

- * The output voltage should not be adjusted to lower voltage than the spec because it may be hiccup mode.

1.7 Output Ripple and Ripple Noise

■ The measuring method Fig.1.1 is recommended because the output ripple noise may be influenced by measurement environment.

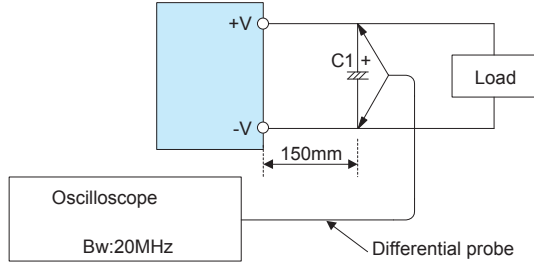

C1 : 22μF of Aluminum electrolytic capacitor

Fig.1.1 Measuring method for Ripple and Ripple Noise

Remarks :

When GND cable of probe with flux of magnetic force from power supply are crossing, ripple and ripple noise might not measure correctly.

Please note the measuring environment.

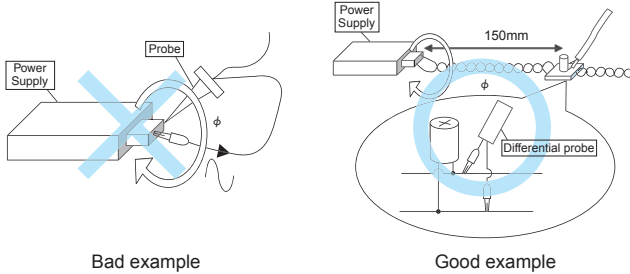

Fig.1.2. Example of measuring output ripple and ripple noise

1.8 Remote ON/OFF

- A unit has a remote ON/OFF function.
- The remote ON/OFF function can be operated by sending signals to CN3. Please see Table 1.2 and Table 1.3 for specifications and Fig.1.3 for connecting examples.
- Please note the following when using the remote ON/OFF function.
 - ① The output stops when a current flows to RC.
 - * Reverse logic option (-R) is available. Refer to section 5. Option.
 - ② The current flown to RC is a 15mA max.
 - ③ If the output voltage is turned off through the remote ON/OFF circuit, the WRN signals and the PG signals keep "Low".
 - ④ Description in this section is based on the assumption that you will use one unit alone. If you are planning to use the units in parallel operation or use multiple units for a single system, please check necessary voltage and current values.
- Please wire carefully. If done incorrectly, the internal components of the unit may be damaged.
- Remote ON/OFF circuits (RC and RCG) are isolated from input, output, FG and various function terminals.

Table 1.2 Specifications of remote ON/OFF (RC-RCG)

Output	Between RC and RCG
ON	L level (0 to 0.5V) or open
OFF	H level (4.5 to 15V)

Table 1.3 Specifications of remote ON/OFF (Case of Fig.1.3)

Connection method	Fig.1.3 (a)	Fig.1.3 (b)	Fig.1.3 (c)
Output ON	SW open (0.1mA max)	SW close (0.5V max)	SW close (0.5V max)
Output OFF	SW close (3mA min)	SW open (0.1mA max)	SW open (0.1mA max)
Base pin	RCG	AUXG	RCG, AUXG

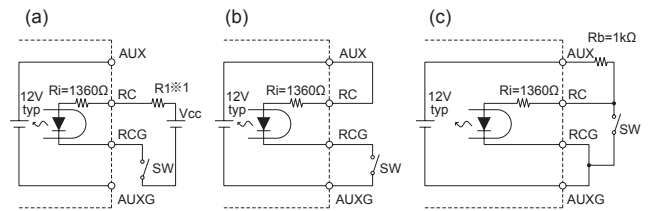

Fig.1.3 Examples of connecting method for remote ON/OFF

*1 If an external voltage (VCC) is within the range of 4.5 - 15V, a current limiting resistor R1 is not necessary. If it exceeds 15V, connect the current limiting resistor R1.

To calculate a current limiting resistance value, please use the following formula.

$$R1[\Omega] = \frac{V_{cc} - (1.1 + R_i \times 0.005)}{0.005} \quad R_i : 1360[\Omega] \quad V_{cc} : \text{External power supply}$$

1.9 Remote Sensing

- A unit has a built-in remote sensing function. (Except for the 200V and 300V output versions.)
 - When remote sensing is not used, +S and -S can be left open.
- Please see Fig. 1.4 if you use the remote sensing function.
- When you use the remote sensing function, please wire from +S and -S on CN1 or CN2. Harnesses are sold separately. For details, refer to the item of option parts.
- When you use the remote sensing, please note the followings.
 - ① Wire carefully. When a connection of a load line becomes loose (due to such factors as loose screw), the load current flows to the sensing line and internal circuits of the power supply may be damaged.
 - ② Use a sufficiently thick wire to connect between the power supply and the load and keep the line drop at 0.3V or below.
 - ③ Use a twisted pair wire or a shielded wire as the sensing line.
 - ④ Do not draw the output current from +S or -S.
 - ⑤ When the remote sensing function is used, the output voltage of the power supply may show an oscillating waveform or the output voltage may dramatically fluctuate because of an impedance of wiring and load conditions. Please check and evaluate carefully before using the remote sensing function.

If the output voltage becomes unstable, we suggest you to try to connect C1, C2, C3, R1, R2 and R3.

⑥ If the output voltage is unstable because the sensing line is long, adjust R1 and R2. Please contact us for details.

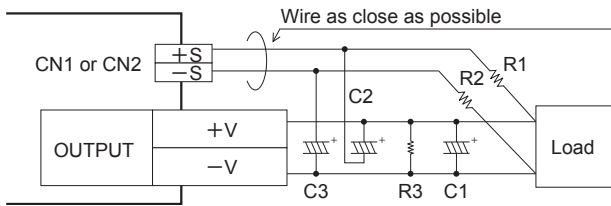

Fig. 1.4 When using remote sensing function

1.10 Isolation

■ When you run a Hi-Pot test as receiving inspection, gradually increase the voltage to start. When you shut down, decrease the voltage gradually by using a dial. Please avoid a Hi-Pot tester with a timer because when the timer is turned ON or OFF, it may generate a voltage a few times higher than the applied voltage.

1.11 Signal Output (LED/Warning/Alarm)

■ Functions of LED indicators and Output of Warning/Alarm are shown below. LED indicators and Output of Warning/Alarm are signals to check the presence/absence of voltage at the output terminal of a power supply and to detect warning/fault conditions. The timing of signals might vary depending on input and load conditions. Please evaluate thoroughly.

Table 1.4 Description of LED indicator

LED indicator	Condition	Output voltage
OFF	No input	OFF
Blue - ON	Normal condition	ON
Blue - Blinking	Output OFF by RC signal	OFF
Amber - Blinking	Warning condition (refer to Table 1.5)	ON
Amber - ON	Fault condition (refer to Table 1.6)	OFF

Table 1.5 Description of Warnings

Warning	Output of Warning
WRN Warning condition · AC input voltage is out of specification. · Output voltage exceeds specification. · Output voltage fall below the setting value. · Overcurrent condition. · Overheat condition. · FAN alarm	Open collector method Good : L level (0 to 0.5V at 3mA) Bad : H level or Open (35Vmax)

Table 1.6 Description of the alarms (PG signal)

Alarm	Output of Alarm
PG Fault condition · Input voltage anomaly · Thermal protection is activated. · Overvoltage protection is activated. · Overcurrent protection is activated. · FAN stop	Open collector method Good : L level (0 to 0.5V at 3mA) Bad : H level or Open (35Vmax)

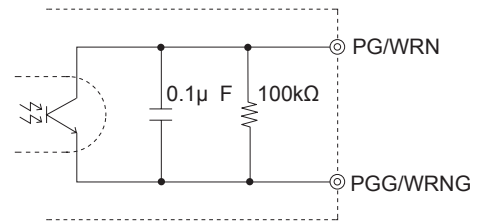

Fig.1.5 Internal circuit of PG / WRN

■ Please note the followings for warnings (WRN signal) and the alarms (PG signal).

- ① The time it takes until the WRN signals and the PG signals turn "High" vary depending on conditions.
- ② If the output voltage is turned off through a remote ON/OFF circuit, the WRN signals and the PG signals keep "Low".

■ The WRN signal (Warning) circuit and the PG signal (Alarm) circuit are isolated from input, output, FG and various function terminals.

1.12 Sequence Diagram

(1) Turn ON/OFF by Remote ON/OFF control

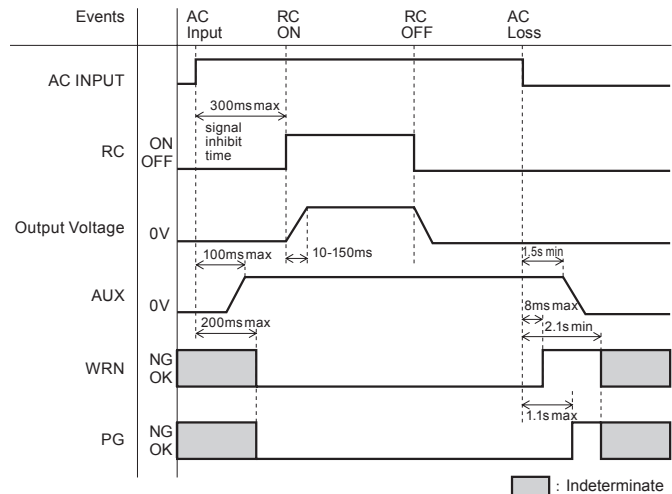

Fig.1.6 Sequence time chart by Remote ON/OFF control

(2) Turn ON/OFF by AC Input

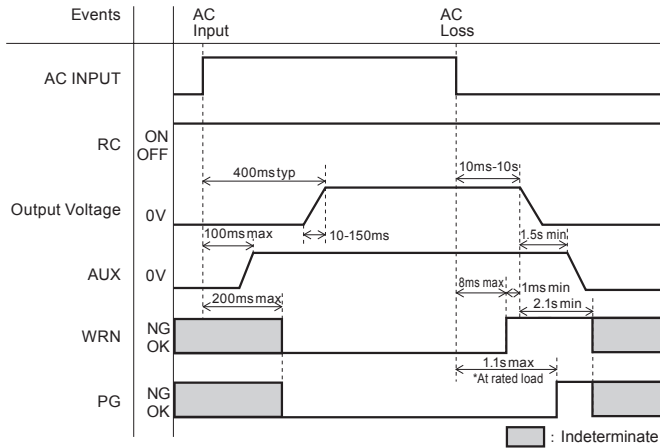

Fig.1.7 Sequence time chart by AC Input

2 Series/Parallel Operation

2.1 Series Operation

- Units can be operated in series when connected as shown in Fig. 2.1.
- The maximum combined output voltage in series operation depends on the model. Please refer to Table 2.1. However, safety approvals may become invalid depending on the combined voltage. Please contact us for details.

Table 2.1 Combined output voltage

Model	Combined output voltage [V]
HFA3500TF-48	400 max
HFA3500TF-65	400 max
HFA3500TF-90	1,000 max
HFA3500TF-130	1,000 max
HFA3500TF-200	1,000 max
HFA3500TF-300	1,000 max

- Please note that the maximum current available to the load is equal to the current of the lowest rated supply in the string.
- If any one of the power supply units stops operating (whether due to a failure, activation of a protection circuit, or shutdown via the remote control function), please ensure that all remaining power supply units are also shut down.

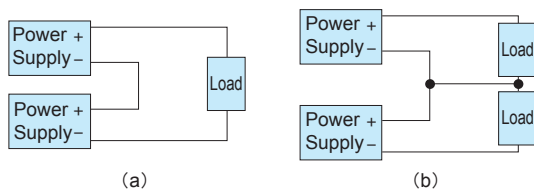

Fig.2.1 Examples of connecting in series operation

2.2 Parallel Operation/Master-slave Operation

- Units can be operated in parallel when connected as shown in Fig. 2.1.

Please parallelly connect CB, VTRM and COM of each unit in parallel operation.

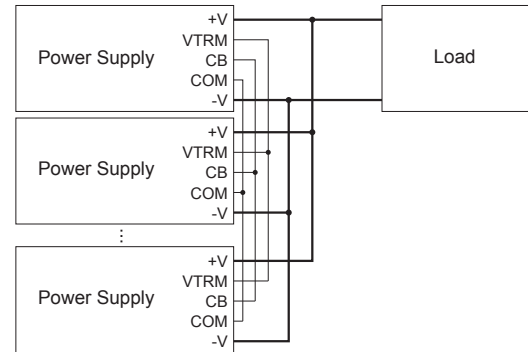

Fig.2.2 Example of parallel connection

- Differences in the output current values among the power supplies in parallel connection are 10% at most. Please make sure that the sum of the output current does not exceed obtained value from the following equation.

$$\begin{aligned} & \text{(Output current in parallel operation)} \\ & = (\text{Rated current per unit}) \times (\text{Number of units}) \times 0.9 \end{aligned}$$

- When the number of units in parallel operation increases, the input current also increases. Please design input circuitry (including circuit pattern, wiring and current capacity for equipment) carefully.
- Connect the output wiring of each power supply as close to the output terminal as possible in parallel operation. Also, make sure that the wiring impedance of the connected point from each power supply become even. Otherwise, the output current balance circuit may become inoperative.
- The maximum number of units in parallel operation are 10 or less.
- The output voltage in parallel operation can be adjusted by the potentiometer of just one power supply. (Master-slave operation)
To do so, select one power supply as the master unit and turn the potentiometers of the other (slave) power supplies clockwise until hear the sound or short SLV_EN and SGND.
Once you have done this, the output voltage can be adjusted by the potentiometer of the master unit.
- Parallel connection to other products is not available.

* Notes for parallel operation

- Specification value of ripple and ripple noise is tripled.
- Load regulation is 3% of the rated output voltage.

2.3 N+1 Parallel Redundancy Operation

- N+1 parallel redundancy operation is available for improved system reliability.
- If you add one extra power supply in parallel operation, even if one of the power supplies in your system fails, the remaining non failed power supplies continue to sustain the system.
If one of the power supplies stops operating, the output voltage may change about 5%.
- Please shut off the input voltage when you replace a failed power supply.

- Hot-swap or Hot-plug is not available.
- 2 or more power supplies failures may cause the output voltage to decrease and the system to shut down. Immediate replacement is recommended when a power supply has failed.
- Please contact us for the detail of series, parallel and N+1 redundancy operations.

3 Life Expectancy and Warranty

■ Life Expectancy

Please see the following tables for life expectancy.

Table 3.1 Life Expectancy

Mounting	Cooling method	Average ambient temperature	Life Expectancy	
			0% ≤ lo ≤ 75%	75% < lo ≤ 100%
All direction	Forced air cooling (internal fan)	Ta = 35°C or less	10 years	6 years
		Ta = 50°C	5 years	3 years
		Ta = 70°C	3 years	-

* This lifetime includes a built-in fan lifetime.

■ Life expectancy (R(t)=90%) of fan depends on use conditions as shown in Fig.3.1.

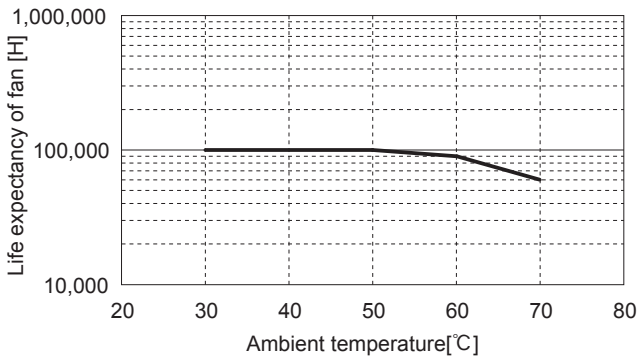

Fig.3.1 Life expectancy

■ Warranty

Please see the following table for warranty. The warranty period is 5 years maximum.

Table 3.2 Warranty

Mounting	Cooling method	Average ambient temperature	Warranty term	
			0% ≤ lo ≤ 75%	75% < lo ≤ 100%
All direction	Forced air cooling (internal fan)	Ta ≤ 50°C	5 years	3 years
		50°C < Ta ≤ 70°C	3 years	-

4 Others

4.1 Auxiliary Power (AUX)

- The power supplies can generate an auxiliary power (AUX: 12V 1A) from CN3 to provide for remote ON/OFF and external circuits.
- AUX is isolated from other (input, output, FG, and various function terminals other than SLV_EN) circuits.
- The output current of the auxiliary power should not exceed 1A because it may cause the damage of the internal circuit or malfunction. The input current of a DC-DC converter at start-up will increase several times. If it will be connected to AUX, check the current whether it is within the spec.
- If a model that has a current foldback characteristic is connected to a non-linear load such as lamp or motor, or to a constant current load, it may not start up. Please see the characteristics below.

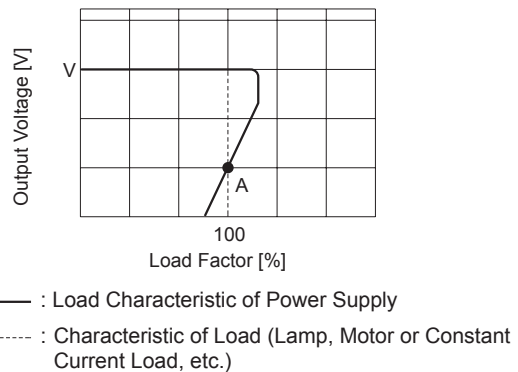

— : Load Characteristic of Power Supply
 - - - : Characteristic of Load (Lamp, Motor or Constant Current Load, etc.)

Note : The output may be locked out at Point A when the unit is connected to a lamp, motor or constant current load.

Fig.4.1 Current Foldback Characteristic

4.2 External Output Capacitors

- Depending on the external capacitor, resonance may occur due to ESR, ESL, and wiring inductance, so please be careful of ripple increase.
- If the external capacitor is too large, the output voltage may not start up.
- Please do not connect the external capacitor during operations.
- Please see Table 4.1 for maximum value of external output capacitors. If the external output capacitors exceeds the value shown in Table 4.1 please contact us for details.
- WRN signal may output at start-up caused by charging current to the capacitor when the external capacitor is connected. Please contact us for details.

Table 4.1 Maximum value of external output capacitors

Model	Maximum value of external output capacitors [μ F]
HFA3500TF-48	0 to 75,000
HFA3500TF-65	0 to 75,000
HFA3500TF-90	0 to 37,500
HFA3500TF-130	0 to 37,500
HFA3500TF-200	0 to 18,500
HFA3500TF-300	0 to 7,500

4.3 External Component (EMI/EMC Filter)

■The unit will be able to comply with the class B conducted noise by adding external EMI/EMC filter.

Recommended EMI/EMC filter

HFA3500TF : TAC-30-683 (COSEL)

4.4 Grounding

■Ensure that the input FG terminal is connected to safety ground of the system.

4.5 Variable Speed Fan

■The power supply has built-in variable speed cooling fan. The fan speed is a function of load and ambient temperature.

5 Options

5.1 Outline of Options

*Please contact us for details of specifications and lead time.

*You can combine multiple options.

● -R

■The logic of the remote in -R option is reversed from the standard unit. Remote ON/OFF specification of Option-R is on Table 5.1 and Table 5.2.

Table 5.1 Remote ON/OFF specification of Option-R (RC-RCG)

Output	Between RC and RCG
OFF	L level (0 to 0.5V) or Open
ON	H level (4.5 to 15V)

Table 5.2 Remote ON/OFF specification of Option-R (Case of Fig.1.3)

Connection method	Fig.1.3 (a)	Fig.1.3 (b)	Fig.1.3 (c)
Output OFF	SW open (0.1mA max)		SW close (0.5V max)
Output ON	SW close (3mA min)		SW open (0.1mA max)
Base pin	RCG	AUXG	RCG, AUXG

● -G

■-G option has the lower leakage current spec.

■Differences from standard versions are summarized in Table 5.3.

Table 5.3 Low leakage current type

Specifications	HFA3500TF	Remarks
Leakage Current	0.5mA max	480VAC 60Hz
Conducted Noise	N/A	
Output Ripple Noise	150% of standard units	

● -I4

■Option -I4 models provide MODBUS-RTU communication interface.

■Please refer to "HFA Series MODBUS Communication Manual" for details.

■A,B,SGND,ADDR0 and ADDR1 terminal are not isolated from AUX.

■A,B,SGND,ADDR0 and ADDR1 terminal are isolated from input,output,FG,CN1,CN2,RC,WRN and PG terminal.

■The connector CN3 is the interface for MODBUS communication.