

Extended-UART

COSEL

AME Series
Extended-UART Manual



AME series ---Extended-UART---

		Page
1. Overview		1
2. Extended-UART Wiring and Connection		1
2.1	Extended-UART pins of AME series	1
2.2	Connection method	2
2.3	Internal circuit and recommended value of pull-up resistor	2
2.4	Address setting	3
3. Communication Specifications		4
3.1	Communication specifications	4
3.2	Note	4
4. Communication Protocol		5
4.1	Overview	5
4.2	Communication frames and packets	5
4.3	Structure of data bit	6
4.4	Check sum	6
4.5	Data format of command packet	7
4.6	Data format of reply packet	8
4.7	Reply packet in case of communication error	8
5. Hardware Specifications of Extended-UART		9
5.1	Absolute maximum ratings for communication terminals	9
5.2	Electrical characteristics of communication terminals	9
5.3	Wiring length	9
5.4	Electrical characteristics of communication signal	10
6. Command Specifications of Extended-UART		11
6.1	Outline of commands in Extended-UART	11
6.2	Commands to turn output voltage on/off	15
6.3	Commands to set output voltage	20
6.4	Commands to set constant current	23
6.5	Commands to set output voltage sequence	26
6.6	Commands to set accessory functions	32
6.7	Monitor commands	36
6.8	State acquisition commands	38
6.9	Commands to set address, memory, and communication	41
6.10	Commands to acquire product information	48
Appendix		
Appendix1	List of Extended-UART commands	Appendix-1
Appendix2	Availability and accuracy of Extended-UART commands index	Appendix-4 I-1
A. Revision history		A-1

Note: The contents described in this document are those available at the time of publication and are subject to change without prior notice due to product improvement and corresponding changes in the specifications. Please check the web page of COSEL for the latest version.

We have paid full attention to ensure the accuracy of this document. We will not be responsible for any damages, including those due to misstatement and/or missing information, and indirect faults resulting from the use of the information in this document.

1. Overview

Extended-UART is a communication protocol that enables single-wire and bi-directional communications among multiple units using a software and the isolation to the standard UART which is the general-purpose communication.

With this product, monitoring of the operational status of the power supply and changing of various set values are enabled by the Extended-UART.

In addition, the non-volatilization memory in AME can maintain various set values and information even if input voltage is shut off.

The communication system consists of a master and slaves. One master like a UART module can connect to up to four slaves which is AME units.

Communications partner is specified by the "address" set for each slave.

2. Extended-UART Wiring and Connection

2.1 Extended-UART pins of AME series

Tables 2.1 and 2.2 show names and functions of pins related to the Extended-UART in this product.

Table 2.1 Function of pins related to Extended-UART on CN1

Pin number	Pin name	Function
7	INFO	Extended-UART signal
8	INFOG	Extended-UART signal ground

Table 2.2 Function of pins related to Extended-UART on CN2

Pin number	Pin name	Function
2	SGND	Signal ground
5	ADDR0	Address bit 0
6	ADDR1	Address bit 1
7	ADDR2	Address bit 2
8	SGND	Signal ground

*AUXG is not isolated to SGND.

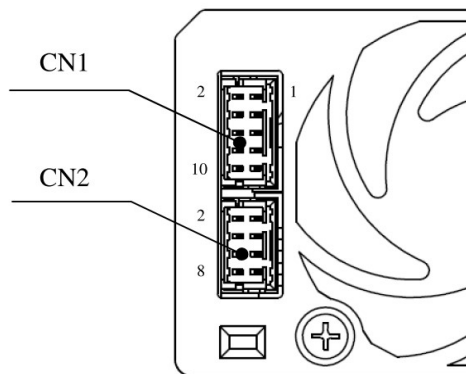
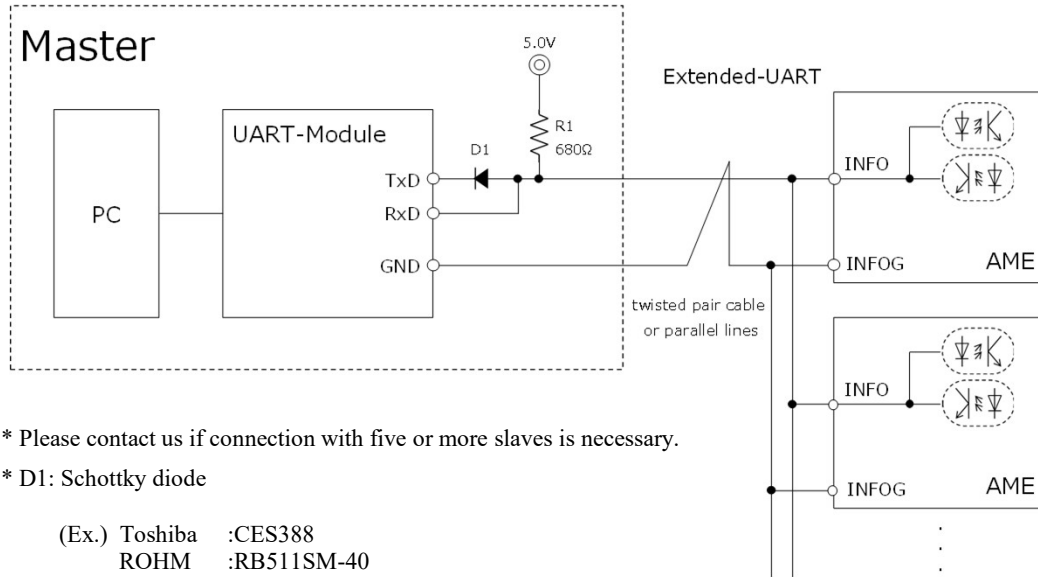

Figure 2.1 AME series connector

2.2 Connection method

Figure 2.2 shows a connection example for the Extended-UART.



* D1 is not required if TxD uses an open collector UART module .
 Please connect TxD and RxD directly.

* Depending on the type of UART module, the Low level may not meet the specification due to high internal impedance.

Confirmed UART module

UB232R(FTDI Chip)
 AE-UM232R (AKIZUKI DENSHI TSUSHO)

Figure 2.2 Connection example of Extended-UART

2.3 Internal circuit and recommended value of pull-up resistor

2.3.1 Internal circuit

Figure 2.3 shows the internal circuit of INFO terminal.

Terminals of the communication function (INFO/INFOG) are isolated from the other circuit (input, output, FG, various function terminals) .

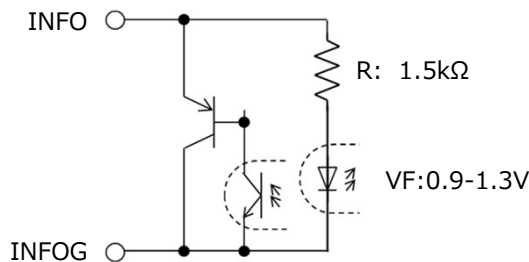

Figure 2.3 Internal circuit of INFO

2.3.2 Recommended value of pull-up voltage and resistor

A pull-up resistor is required on the communication line.

Table 2.3 shows recommended values of pull-up voltage and resistor.

Table 2.3 Recommended value of pull-up voltage and resistor

No.	Item	Unit	Value	Remark
1	Pull-up voltage	V	5	
2	Pull-up resistance	Ω	680	

The voltage of high level depends on the number of connected units because of the internal impedance of INFO terminal.

Check the threshold voltage of the UART module to be used.

Table 2.4 Voltage of high level by number of units

No.	Number of connected units	High level (V)	Pull-up condition
1	1	3.8	Pull-up voltage : 5V Pull-up resistance : 680Ω
2	2	3.1	
3	3	2.7	
4	4	2.5	

2.4 Address setting

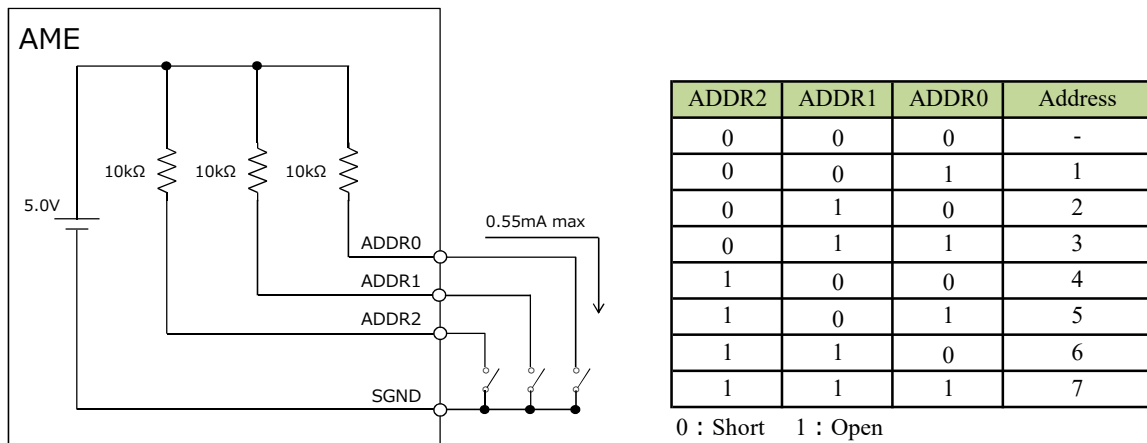

Figure 2.4 Method of address setting

The address can be from "1" to "7". (It cannot be set to "0".)

The address can be set by connection conditions (short/open) of address setting pins(ADDR0, ADDR1, ADDR2) and the signal ground pin(SGND).

The address setting pins (ADDR0, ADDR1, ADDR2) are isolated from the input, the output, FG and CN3.

3. Communication Specifications

3.1 Communication specifications

Table 3.1 shows the communication specifications of the AME series.
 The master like the UART module should be set according to Table 3.1.

Table 3.1 Communication specifications

No.	Item	Specification	
1	Communication method	Single-wire, half-duplex	
2	Synchronization scheme	Start-stop synchronization	
3	Connection configuration	1 : N (Master : Slave)	
4	Maximum number of connected units	4*	
5	Communication speed	2400 bps	
6	Flow control	None	
7	Data format	Data length	8 bits
8		Stop bit	1 bit
9		Parity	1 bit, Even parity
10		Transfer direction	LSB first

* Please contact us if connection with five or more slaves is necessary.

3.2 Note

Wait for more than 3ms after receiving the reply packet.
 If the wait time is short, the slave cannot communicate.

4. Communication Protocol

4.1 Overview

The communication operation in the Extended-UART starts when the master transmits a command packet to a slave, and ends when the corresponding slave (AME) transmits a reply packet to the master.

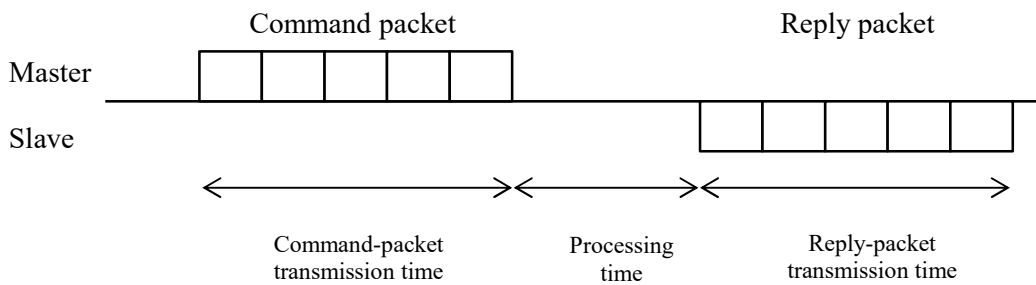

Figure 4.1 Overview of communication operation

- Command-packet transmission time : The transmission time should be 250 msec or shorter.
 If the transmission time exceeds 250 msec, the slave fails with a timeout error and becomes the waiting mode to receive a packet.
- Processing time : Maximum 200 msec
- Reply-packet transmission time : Maximum 25 msec

If the address contained in the received command packet matches its own address, the slave sends a reply-packet, but if it does not match, it will not send anything.

Extended-UART is half-duplex communication, do not transmit command packets during reply packet transmission.

4.2 Communication frames and packets

Both the command packet and the reply packet are composed of five frames.

Each communication frame has a total of 11 bits, consisting of a start bit, data bits (8 bits), a parity bit, and a stop bit. (See Figure 4.2.)

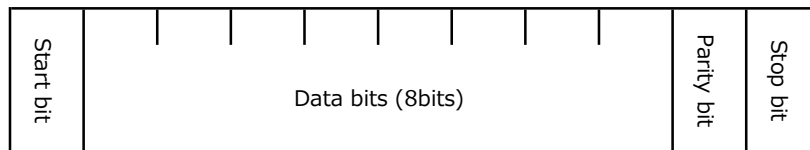

Figure 4.2 Structure of communication frame

4.3 Structure of data bit

For all communication frames, the high three bits contain the address and the low five bits contain data.

The robustness of the communication data is maintained by the specification that all communication frames have the address information.

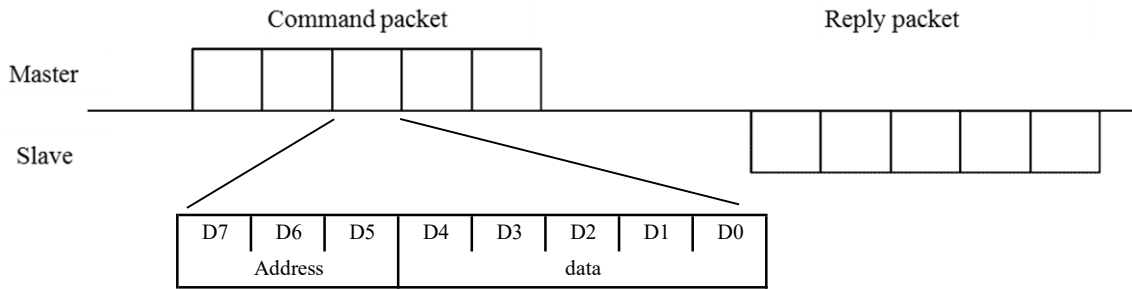

Figure 4.3 Structure of data bit

【Example of address setting】

When communicating with the slave which has "6" of address.

"6" → 110b

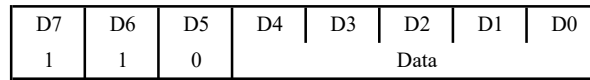

Figure 4.4 Example of address setting

4.4 Check sum

Both the command packet and reply packet have a checksum for detecting communication errors.

All data excluding the address in Fram 0, 2, 3 and 4 are totaled, and the low four bits are stored to 1 to 4 bit in Frame 1.

The checksum configuration is shown in Figure 4.5.

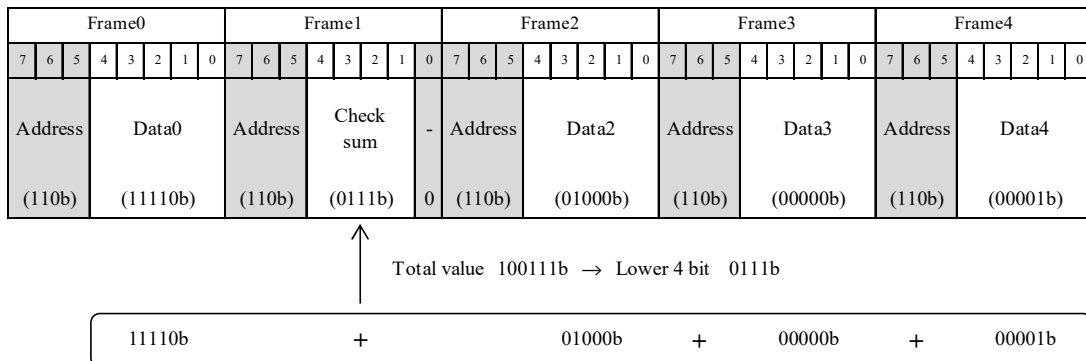

* An example is shown in ().

Figure 4.5 Structure of checksum

4.5 Data format of command packet

The command in the command packet of the Extended-UART is the variable length format as shown in Table 4.1.

Table 4.1 Command types

No.	Type	Argument length	Remark
1	5-bit command	16 bits	It is the command to transmit numerical value of 0 to 65536 to the slave.
2	10-bit command	10 bits	It is the command to transmit numerical value of 0 to 1023 to the slave.
3	20-bit command	None	It is the command which does not have any argument.

(1) Format of 5-bit command

5-bit command is assigned to the data part of communication frame 0.

The most significant bit in 16 bits of arguments is assigned to 0 bit in Frame 1. The remaining 15 bits are divided into three with 5 bits and are assigned to data parts in Frame 2, 3 and 4.

Figure 4.6 shows the format for a 5-bit command.

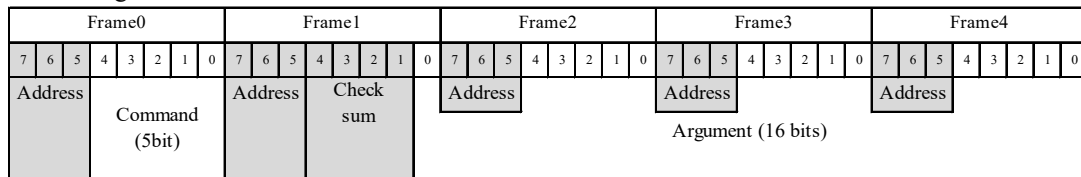

Figure 4.6 Data format of 5-bit command

(2) Format of 10-bit command

10 bits of commands are divided into two with 5 bits and are assigned to the data part of Frames 0 and 2.

10 bits of arguments are divided into two with 5 bits and are assigned to the data part of Frames 3 and 4.

Figure 4.7 shows the format for a 10-bit command.

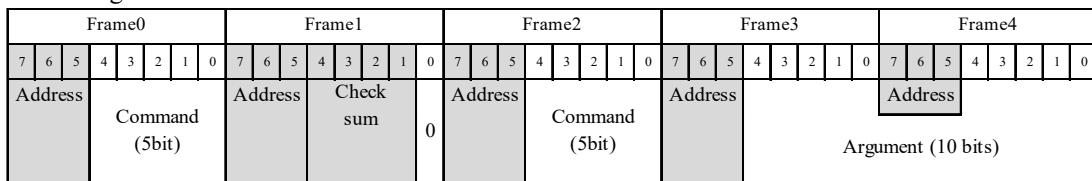

Figure 4.7 Data format of 10-bit command

Specify "0" for bit 0 of communication frame 1.

(3) 20-bit command

20 bits of commands are divided into four with 5 bits and are assigned to the data parts of Frames 0, 2, 3, and 4. The 20-bit command does not have any arguments.

Figure 4.8 shows the format for a 20-bit command.

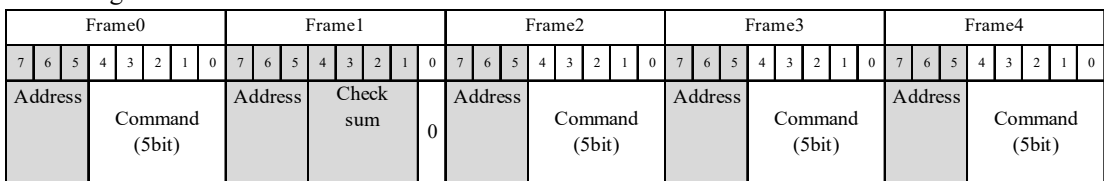

Figure 4.8 Data format of 20-bit command

Specify "0" for bit 0 of communication frame 1.

4.6 Data format of reply packet

An Extended-UART reply packet consists of the address information, the identifier information, the checksum, and the return value.

The format of the reply packet is shown in Figure 4.9.

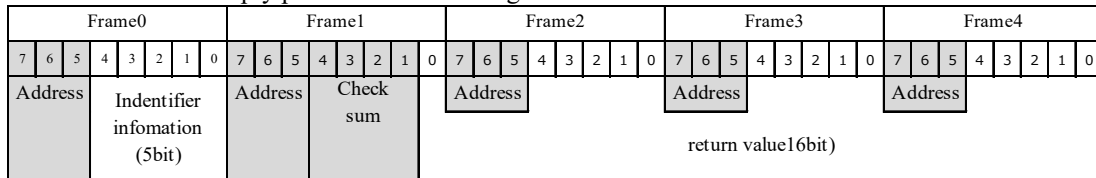

Figure 4.9 Data format of reply packet

Identifier information: when the communication is normal, the command value in Frame 0 of the command packet is returned.

4.7 Reply packet in case of communication error

(1) Hardware error

If the following hardware error occurs, any reply packet is not transmitted because the slave cannot recognize the command packet.

- 1) Parity error
- 2) Frame error
- 3) Timeout (see Section 4.1)

(2) Software error

If the command packet sent from the master had errors, the reply packet indicating an error is transmitted.

Identifier information: 11111b(5bit)

Return value : Error code as shown in Table 4.2

Table 4.2 Error codes

No.	Error code (Decimal)	Error description
1	0	No corresponding command
2	1	The argument outside settable range is specified. (e.g. Specifying the argument exceeding 120% of the rated output voltage.)
3	2	Arguments are inconsistent. (e.g. Specifying the lowest value which is higher than the highest value.)
4	3 224	The specified command is not valid. (e.g. Transmitting the write command at the time when the protection of write command is enabled.)
5	4	The state of the internal process is busy. (e.g. The command is received before the process is completed.)
6	5	The command to the empty slot is transmitted. (e.g. The empty slot is selected.)
7	6	The command that do not correspond to the setting target is transmitted. (e.g. The command to monitor the output voltage is transmitted to the front-end module.)
8	256	Checksum mismatch
9	8449	Internal communication error (e.g. The target output module is not working by GL.)

5. Hardware Specifications of Extended-UART

5.1 Absolute maximum ratings for communication terminals

Table 5.1 shows the absolute maximum ratings of the Extended-UART terminals.

Table 5.1 Absolute maximum ratings

Terminal	Item	Min	Max	Unit	Remark
INFO - INFOG	Applied voltage	-0.3	5.5	V	

5.2 Electrical characteristics of communication terminals

Table 5.2 shows the electrical characteristics of the Extended-UART terminals.

Table 5.2 Electrical characteristics

Terminal	Item	Min	Max	Unit	Remark	
INFO - INFOG	Signal output	High level of output voltage		open (No output)		
		High level of output current		open (No output)		
		Low level of output voltage	-	1.0	V	
		Low level of output current	-	-12.0	mA	
	Signal input	High level of input voltage	2.5	-	V	
		High level of input current	1.0	-	mA	
		Low level of input voltage	-	0.8	V	
		Low level of input current	-	0.5	mA	

The communication function terminals (INFO/INFOG) are isolated from other terminals (the input, the output, FG, some function terminals).

5.3 Wiring length

Table 5.3 shows the allowable wiring length between the Extended-UART terminal and the master device.

Table 5.3 Allowable wire length

Terminal	Item	Min	Max	Unit	Remark
INFO - INFOG	Wiring length	-	20	m	

Use wires which have low inductance such as twisted pair wires or parallel wires.

The communication signal might be delayed due to the parasitic capacitance and/or inductance. Confirm if the rise and fall times meet the rating on Item 5.4.

Command Specifications of Extended-UART

6.1 Outline of commands in Extended-UART

Table 6.1, 6.2, 6.3 and 6.4 are outline of commands in Extended-UART.

The corresponding commands differ depending on the module. See Appendix 2 for corresponding commands.

Some commands require selection of the setting target by SET_SELECTION_CH. See to 6.9.1 for the target command.

Table 6.1 Command outline (1/4)

6.2 Commands to turn output voltage on/off		
1	CTL_REMOTE_ON	:Outputs in all slots get enabled. W
2	CTL_REMOTE_OFF	:Outputs in all slots get inhibited. W
3	CTL_CH_REMOTE_ON	:The output in the arbitrary slot gets enabled. W
4	CTL_CH_REMOTE_OFF	:The output in the arbitrary slot gets inhibited. W
5	CTL_REMOTE_ON_CH	:The output in the selected slot gets enabled. W
6	CTL_REMOTE_OFF_CH	:The output in the selected slot gets inhibited. W
7	READ_REMOTE_CH_PRM	:Returning the output status information (enabled/inhibited) set by communication in all slots. R
8	READ_REMOTE_PRM	:Returning the output status information (enabled/inhibited) set by communication. R
9	READ_REMOTE_CONTROL	:Returning the output status information (enabled/inhibited). R
10	READ_REMOTE_START_UP_PRM	:Returning the output status information (enabled/inhibited) set by communication at AC input. R
11	CTL_POWER_OFF_GI	:Putting the unit into a state of "GI(Global Inhibit)". W
12	CTL_POWER_ON_GI	:Deactivating "GI(Global Inhibit)". W
13	READ_CTL_GI	:Returning the state about "GI(Global Inhibit)". W
14	SET_GI_TERMINAL_MODE_GI	:Setting the GI2 terminal to work for GI function. W
15	SET_GI_TERMINAL_MODE_RC	:Setting the GI2 terminal to work for "output modules inhibit" function. W
16	READ_CTL_GI	:Returning a setting of the GI2 terminal. W
17	CTL_RESET_LATCH	:Clearing lutch off. W
6.3 Commands to set output voltage		
1	SET_VOUT	:Setting the output voltage. W
2	READ_VOUT_PRM	:Returning the output voltage setting. R
3	SET_VOUT_FACTORY_SETTING	:Restoring a factory setting for the output voltage. W
4	READ_VOUT_REFERENCE	:Returning the controlling value for the output voltage. R
5	SET_VOUT_UPPER_LIMIT	:Setting a upper limit for the output voltage adjustment range. W
6	READ_VOUT_UPPER_LIMIT_PRM	:Returning a upper limit for the output voltage adjustment range. R
7	SET_VOUT_LOWER_LIMIT	:Setting a lower limit for the output voltage adjustment range. W
8	READ_VOUT_LOWER_LIMIT_PRM	:Returning a lower limit for the output voltage adjustment range. R
9	SET_VOUT_LIMIT_FACTORY_SETTING	:Restoring a factory default value of a upper and a lower limit for the output voltage adjustment range. W

R : Read command W : Write command

Table 6.1 Command outline (2/4)

6.4 Commands to set constant current			
1	SET_CC_MODE_ITRM	:The constant current can be set by the voltage on the ITRM terminal.	W
2	SET_CC_MODE_INFO	:The constant current can be set by the communication function.	W
3	READ_CC_MODE_PRM	:Returning a setting method of the constant current.	R
4	SET_CC	:Setting a value of the constant current.	W
5	READ_CC_PRM	:Returning a value of the constant current.	R
6	SET_CC_FACTORY_SETTING	:Restoring a factory default value of the constant current.	W
7	READ_CC_REFERENCE	:Returning the controlling value for the constant current.	R
8	SET_CC_UPPER_LIMIT	:Setting a upper limit for the constant current adjustment range.	W
9	READ_CC_UPPER_LIMIT_PRM	:Returning a upper limit for the constant current adjustment range.	R
10	SET_CC_LIMIT_FACTORY_SETTING	:Restoring a factory default value of a upper limit for the constant current.	W
11	SET_CC_CONTROL	:Setting a controlled variable of the constant current.	W
12	READ_CC_CONTROL_PRM	:Returning a controlled variable of the constant current.	R
6.5 Commands to set output voltage sequence			
1	SET_TON_DELAY_SLOT	:Setting a power-on delay time.	W
2	READ_TON_DELAY_SLOT_PRM	:Returning a power-on delay time.	R
3	SET_TON_DELAY_FACTORY_SETTING	:Restoring a factory default value of the power-on delay time.	W
4	SET_TOFF_DELAY_SLOT	:Setting a power-off delay time.	W
5	READ_TOFF_DELAY_SLOT_PRM	:Returning a power-off delay time.	R
6	SET_TOFF_DELAY_FACTORY_SETTING	:Restoring a factory default value of the power-off delay time.	W
7	SET_TON_DELAY_VIN	:Setting delay time for activation after AC input.	W
8	READ_TON_DELAY_VIN_PRM	:Returning delay time for activation after AC input.	R
9	SET_START_UP_VIN_AC	:Setting a starting voltage for AC input.	W
10	READ_START_UP_VIN_AC_PRM	:Returning a starting voltage for AC input.	R
11	SET_STOP_VIN_AC	:Setting a stopping voltage for AC input.	W
12	READ_STOP_VIN_AC_PRM	:Returning a stopping voltage for AC input.	R
13	SET_RAMP_RATE	:Setting a ramp rate of the output voltage.	W
14	READ_RAMP_RATE_PRM	:Returns the current change rate of the output voltage.	R

R : Read command W : Write command

Table 6.1 Command outline (3/4)

6.6 Commands to set accessory functions		
1	SET_FAN_MODE_AUTO	:The rotation speed of the built-in air-cooling fan is controlled automatically. W
2	SET_FAN_MODE_FIXED_SPEED	:Setting the rotation speed of the built-in air-cooling fan to the max value. W
3	READ_FAN_MODE_PRM	:Returning the setting for the rotation-speed control of the built-in air-cooling fan. R
4	SET_AUX_VOUT	:Setting the output voltage for the AUX power. W
5	READ_AUX_VOUT_PRM	:Returning the output voltage for the AUX power. R
6	SET_VIN_LV_ALARM	:Setting the input threshold voltage for the alarm signal. W
7	READ_VIN_LV_ALARM_PRM	:Returning the input threshold voltage for the alarm signal. R
8	SET_PR_TERMINAL_MODE_PR	:Setting the PR terminal to work for the abnormal detection. R
9	SET_PR_TERMINAL_MODE_PG	:Setting the PR terminal to work for the detection of the front-end module stoppage. R
10	READ_PR_TERMINAL_MODE_PRM	:Returning a status of the detection function in the PR terminal. R
11	SET_ALARM_STATUS	:Setting abnormal conditions for the alarm signal. W
12	READ_ALARM_STATUS_PRM	:Returning a abnormal state for the alarm signal. R
13	SET_VOUT_LV_ALARM	:Setting the output threshold voltage for an alarm signal. W
14	READ_VOUT_LV_ALARM_PRM	:Returning the output threshold voltage for an alarm signal. R
15	SET_VOUT_HV_ALARM	:Setting a upper threshold of the output voltage for an alarm signal. W
16	READ_VOUT_HV_ALARM_PRM	:Returning a upper threshold of the output voltage for an alarm signal. R
17	SET_VOUT_ALARM_FACTORY_SETTING	:Restoring a factory default value of the output voltage for the alarm signal. W
6.7 Monitor commands		
1	MON_VIN	:Returning a value of the input voltage. R
2	MON_VIN_FREQUENCY	:Returning a value of the input frequency. R
3	MON_VOUT	:Returning a value of the output voltage. R
4	MON_IOUT	:Returning a value of the output current. R
5	MON_OUTPUT_POWER	:Returning a value of the output power. R
6	MON_FAN_SPEED_1	:Returning a value of the rotation-speed control for the built-in air-cooling fan 1. R
7	MON_FAN_SPEED_2	:Returning a value of the rotation-speed control for the built-in air-cooling fan 2. R
8	MON_AUX_VOUT	:Returning a value of the output voltage for the AUX power. R
9	MON_TEMPERATURE_1	:Returning a value of the temperature for internal components. R

R : Read command W : Write command

Table 6.1 Command outline (4/4)

6.8 State acquisition commands			
1	READ_STOP_CODE	:Returning the code representing the halt condition.	R
2	READ_PR_ALARM	:Returning a status of the PR alarm.	R
3	READ_PG_ALARM	:Returning a status of the PG alarm.	R
4	READ_LV_ALARM	:Returning a status of the LV alarm.	R
5	TOTAL_INPUT_TIME_1	:Returning an accumulated time that the input voltage has been applied. (minute)	R
	TOTAL_INPUT_TIME_2	:Returning an accumulated time that the input voltage has been applied. (low 16 bits of hour)	R
	TOTAL_INPUT_TIME_3	:Returning an accumulated time that the input voltage has been applied. (high 16 bits of hour)	R
6	TOTAL_OUTPUT_TIME_1	:Returning an accumulated operation time. (minute)	R
	TOTAL_OUTPUT_TIME_2	:Returning an accumulated operation time. (low 16 bits of hour)	R
	TOTAL_OUTPUT_TIME_3	:Returning an accumulated operation time. (high 16 bits of hour)	R
6.9 Commands to set address, memory, and communication			
1	SET_SELECTION_CH	:Setting a selected slot.	W
2	READ_SELECTION_CH	:Returning the selected slot for setting.	R
3	SET_WRITE_PROTECT_ON	:Enabling a protection for the Write command.	W
4	SET_WRITE_PROTECT_OFF	:Disabling a protection for the Write command.	W
5	READ_WRITE_PROTECT_PRM	:Returning a status of the protection for the Write command.	R
6	SYS_STORE_USER_SETTING	:Storing settings into the internal non-volatile memory.	W
7	SYS_RESTORE_FACTORY_SETTING	:Restoring a factory default for settings.	W
8	READ_STORE_USER_SETTING	:Returning a status of the stored setting in the internal non-volatile memory.	R
9	CTL_ACCUMULATE_MODE_ON	:Enabling the accumulation mode.	W
10	CTL_ACCUMULATE_MODE_OFF	:Disabling the accumulation mode.	W
11	READ_ACCUMULATE_MODE	:Returning a setting status of the accumulation mode.	R
12	CTL_ACCUMULATE_EXEC	:Execution command in the accumulation mode.	W
13	CTL_ACCUMULATE_CLEAR	:Erasing buffer in the accumulation mode.	W
14	SET_ADDRESS	:Setting a communication address.	W
15	READ_ADDRESS_PRM	:Returning a setting value of the communication address.	R
16	READ_ADDRESS	:Returning a communication address.	R
6.10 Commands to acquire product information			
1	READ_SERIAL	:Returning the product serial number.	R
2	READ_LOT_H	:Returning the upper three digits of the product lot number.	R
3	READ_LOT_L	:Returning the lower four digits of the product lot number.	R
4	READ_PRODUCT_INFO	:Returning a information of output module.	R
5	READ_RATED_VOUT	:Returning the rated voltage of the model.	R
6	READ_RATED_IOUT	:Returning the rated current of the model.	R
7	READ_VIN_POINT	:Returning the decimal point position of the return value from MON_VIN command.	R
8	READ_VOUT_POINT	:Returning the decimal point position of the return value from MON_VOUT command.	R
9	READ_IOUT_POINT	:Returning the decimal point position of the return value from MON_IOUT command.	R

R : Read command W : Write command

The function and the setting method for each command are shown below.

Notation

6.x.x MON_VOUT [1Eh] [08h] [01h] [00h] **SELECT**

Command name Command in communication frame Representing a command that
 [0],[2], [3] and [4] (hexadecimal) needs to select(*) the target.
 (Refer to 6.9.1 for the detail.)

*It is necessary to select the microcontroller of communication target ,
 because the power supply has multiple microcontrollers.(Refer to Appendix3.)

6.2 Commands to turn output voltage on/off

6.2.1 CTL_REMOTE_ON [1Eh] [08h] [1Ch] [00h]

This is a command to enable the output voltage. (Remote on/off function.)

With this command, all output voltages get enabled.※1

The factory default is that all output voltages are enabled.

Return value	1
--------------	---

6.2.2 CTL_REMOTE_OFF [1Eh] [08h] [1Ch] [01h]

This is a command to inhibit the output voltage. (Remote on/off function.)

With this command, all output voltages get inhibited.※2

Return value	0
--------------	---

6.2.3 CTL_CH_REMOTE_ON [1Ah] [1Eh] [Argument]

This is a command to enable the output voltage. (Remote on/off function.)

With this command, the output voltages of the arbitrary slots get enabled. The target slots are set by an argument.※1

The relationship between the argument (binary) and the target slots is shown below.

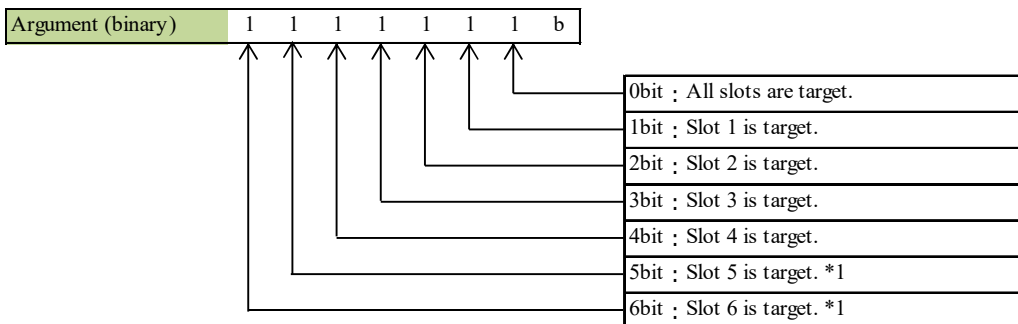

*1 It cannot be set for AME400F and AME600F.

bit value	value : 1 =>	ON
	value : 0 =>	OFF
Settable range	AME400F,AME600F	: 00001 - 11111b
	AME800F,AME1200F	: 0000001 - 1111111b
Examples of argument (AME400F, AME600F)	Argument : 01010b	=> slot1, slot3 ON
	Argument : 00001b	=> all slot ON
Return value	Argument value	

If only empty slot is target, this command is not accepted and an error is returned.
 (Error code 5 : Command to empty slot)

6.2.4 CTL_CH_REMOTE_OFF [1Ah] [1Fh] [Argument]

This is a command to inhibit the output voltage. (Remote on/off function.)

With this command, the output voltages of the arbitrary slots get inhibited. The target slots are set by an argument.※2

The relationship between the argument (binary) and the target slots is shown below.

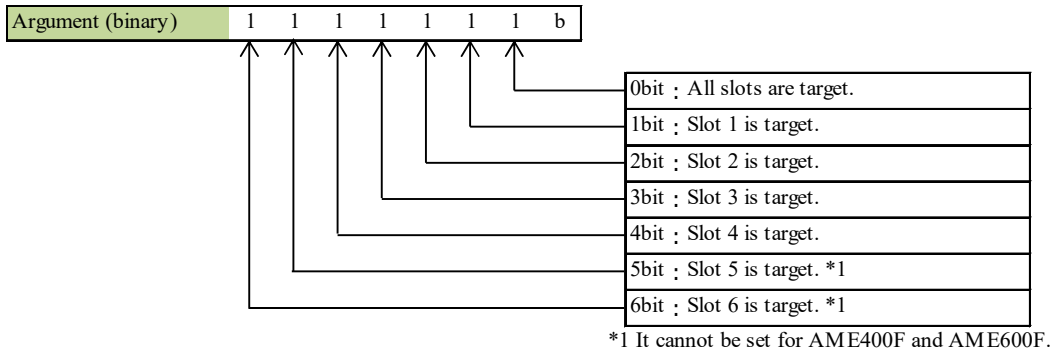

bit value	value : 1	=>	OFF
	value : 0	=>	ON

Settable range	AME400F,AME600F	: 00001 - 11111b
	AME800F,AME1200F	: 0000001 - 1111111b
Examples of argument (AME400F, AME600F)	Argument : 01100b	=> slot2, slot3 OFF
	Argument : 00001b	=> all slot OFF
Return value	Argument value	

If only empty slot is target, this command is not accepted and an error is returned.
(Error code 5 : Command to empty slot)

6.2.5 CTL_REMOTE_ON_CH [1Eh] [08h] [1Ch] [03h]

SELECT

This is a command to enable the output voltage. (Remote on/off function.)

With this command, the output voltages of the selected slots get enabled.※1

The factory default is that all output voltages are enabled.

Return value	1
--------------	---

If the input module is target, an error is returned.
(Error code 6 : Command that do not correspond to the setting target)

6.2.6 CTL_REMOTE_OFF_CH [1Eh] [08h] [1Ch] [04h]

SELECT

This is a command to inhibit the output voltage. (Remote on/off function.)

With this command, the output voltages of the selected slots get inhibited.※2

Return value	0
--------------	---

If the input module is target, an error is returned.
(Error code 6 : Command that do not correspond to the setting target)

※1 When OFF is specified by the RC terminal, the output voltage will not turn ON.

※2 The output voltage will turn OFF, regardless of the specification by the RC2 terminal

6.2.7 READ_REMOTE_CH_PRM [1Eh] [09h] [1Eh] [09h]

This command returns the output status information (enabled/inhibited) that have been set by communication in all slots.

The relationship between the argument (binary) and target slots is shown below.

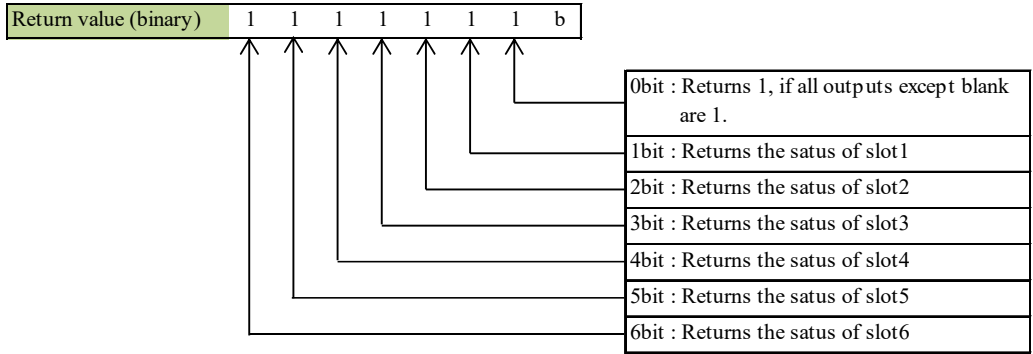

Status	Return value : 0 => OFF or blank
	Return value : 1 => ON
Examples of return value	Return value : 01010b => slot1, slot3 ON
	Return value : 11011b => slot1, slot2, slot3 ON *If slot2 is blank.
	Return value : 11111b => slot1, slot2, slot3, slot4 ON

6.2.8 READ_REMOTE_PRM [1Eh] [09h] [1Eh] [08h]

SELECT

This command returns the output status information (enabled/inhibited) that have been set by communication.

Status	Return value:0 => OFF
	Return value:1 => ON

If the input module is target, an error is returned.

(Error code 6 : Command that do not correspond to the setting target)

6.2.9 READ_REMOTE_CONTROL [1Eh] [09h] [1Eh] [01h]

SELECT

This command returns the output status information (enabled/inhibited).

Status	Return value:0 => OFF
	Return value:1 => ON

If the input module is target, an error is returned.

(Error code 6 : Command that do not correspond to the setting target)

If the instruction is executed on an output module other than the corresponding output modules, an error is returned. (Error code 6 : Command that do not correspond to the setting target)

6.2.10 READ_REMOTE_START_UP_PRM [1Eh] [09h] [1Eh] [0Ah]

This command returns the output status information (enabled/inhibited) that have been set by communication at AC input.

The relationship between the argument (binary) and target slots is shown below.

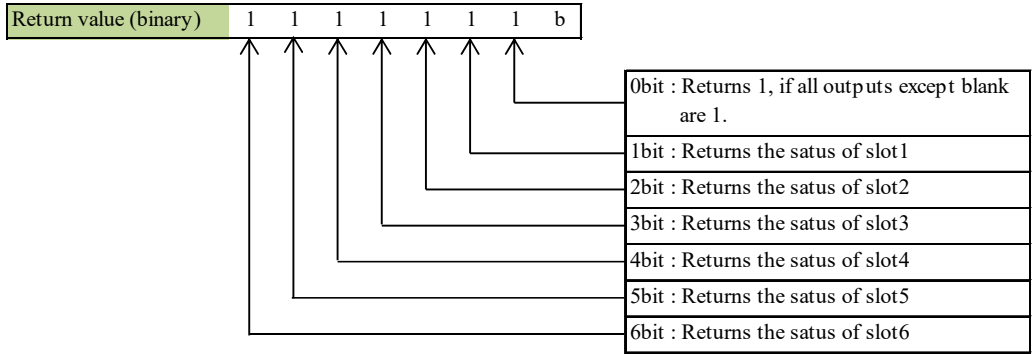

Status	Return value : 0 => OFF or blank
	Return value : 1 => ON
Examples of return value	Return value : 01010b => slot1, slot3 ON
	Return value : 11011b => slot1, slot3, slot4 ON *If slot2 is blank.
	Return value : 11111b => slot1, slot2, slot3, slot4 ON

6.2.11 CTL_POWER_OFF_GI [1Eh] [08h] [1Ch] [06h]

This command render outputs in the unit a state of "GI(Global Inhibit)".

This inhibits all outputs excluding the AUX power.

When the unit is under the state of "GI", the built-in fan stops.

Return value	0
--------------	---

6.2.12 CTL_POWER_ON_GI [1Eh] [08h] [1Ch] [07h]

This command deactivates "GI(Global Inhibit)" and sets outputs to normal state.

This enables outputs which have been inhibited by GI.

This cannot enable any output which have been inhibited by the GI terminal.

And, this cannot enable any output which have been inhibited by the remote on/off function.

Return value	1
--------------	---

6.2.13 READ_CTL_GI [1Eh] [09h] [1Eh] [05h]

This command returns the state about "GI(Global Inhibit)".

Status	Return value:0 => Global inhibit
	Return value:1 => Normal output

6.2.14 SET_GI_TERMINAL_MODE_GI [1Eh] [09h] [0Eh] [02h]

This command sets the GI2 terminal to work for GI function.

After this command is transmitted, outputs can be inhibited as the "GI" state by supplying the current to the GI2 terminal.

This is the factory default.

Return value	0
--------------	---

6.2.15 SET_GI_TERMINAL_MODE_RC [1Eh] [09h] [0Eh] [03h]

This command sets the GI2 terminal to work for the remote on/off function.

After this command is transmitted, only outputs in all slots can be inhibited by supplying the current to the GI2 terminal.

The active PFC and built-in fans do not stop by the remote on/off function.

Return value	1
--------------	---

6.2.16 READ_GI_TERMINAL_MODE_PRM [1Eh] [09h] [1Eh] [06h]

This command returns a setting of the GI2 terminal.

Status	Return value:0 =>	Global inhibit function
	Return value:1 =>	Remote control function

6.2.17 CTL_RESET_LATCH [1Eh] [08h] [1Eh] [1Fh]

This command deactivates the latch that have been activated by OVP, etc. Latches on all outputs are deactivated.

Transmit this after solving all abnormal conditions.

Return value	0
--------------	---

6.3 Commands to set output voltage

The target of commands to set the output voltage is the output module.

If the input module is target, an error is returned.

(Error code 6 : Command that do not correspond to the setting target)

If the instruction is executed on an output module other than the supported output modules, an error is returned.(Error code 6 : Command that do not correspond to the setting target)

6.3.1 SET_VOUT [0Ah] [Argument]

SELECT

This command sets the output voltage.

It sets the value of "Argument/1000" (output module V is "Argument/100") to the output voltage, in V.

When "Output voltage setting by VTRM terminal" function is enabled, this command does not work.

It cannot be set to the value which exceeds the upper limit of the output voltage adjustment range.

It cannot be set to the value which exceeds the upper limit that have been set by "SET_VOUT_UPPER_LIMIT" command.

It cannot be set to the value which exceeds the lower limit that have been set by "SET_VOUT_LOWER_LIMIT" command.

(Error code 1 : The argument outside settable range is specified.)

Example of argument	Except output module V Argument:5010 => 5.010 V
	Output module V Argument:7520 => 75.20 V
Return value	Argument value

The output voltage is set by this command regardless of the voltage adjustment by the internal potentiometer.

The output voltage can be adjusted by the internal potentiometer even after this command has been transmitted.

If the input voltage was shut off, the output voltage set by this command is reset but the one set by the potentiometer remains.

Table 6.3.1 "SET_VOUT" Operation example (AM06-xxxB)

Operation	Return value	Slot1 Output	Remark
1 Power on	—	12.0V	
2 Adjust output voltage of slot 1 to 12.3V by volume	—	12.3V	+0.3V by volume
3 Send "SET_SELECTION_CH" & "1"	1	12.3V	Select slot 1
4 Send "SET_VOUT" & "10000"	10000	10.0V	
5 Adjust output voltage of slot 1 to 10.2V by volume	—	10.2V	+0.2V by volume
6 Input voltage off	—	0V	+0.3V & +0.2V => +0.5V
7 Input voltage on	—	12.5V	+0.3V & +0.2V => +0.5V

6.3.2 READ_VOUT_PRM [1Eh] [09h] [1Bh] [10h]

SELECT

This command returns the value (argument value) set by "SET_VOUT" command.

6.3.3 SET_VOUT_FACTORY_SETTING [1Eh] [09h] [0Bh] [1Fh]

SELECT

This command restores the output voltage set by "SET_VOUT" command to the factory default value.

This command does not reset the adjustment by the internal potentiometer.

Return value	0
--------------	---

Table 6.3.2 "SET_VOUT_FACTORY_SETTING" Operation example (AM06-xxxB)

Operation	Return value	Slot1 Output	Remark
1 Power on	—	12.0V	
2 Adjust output voltage to 12.3V by volume	—	12.3V	+0.3V by volume
3 Send "SET_SELECTION_CH" & "1"	1	12.3V	Select slot 1
4 Send "SET_VOUT" & "10000"	10000	10.0V	
5 Adjust output voltage to 10.2V by volume	—	10.2V	+0.2V by volume
6 Send "SET_VOUT_FACTORY_SETTING"	0	12.5V	+0.3V & +0.2V => +0.5V

The value of the output voltage that has been stored in the non-volatile memory by "SYS_STORE_USER_SETTING" command does not change.

6.3.4 READ_VOUT_REFERENCE [1Eh] [09h] [1Bh] [00h]

SELECT

This command returns the controlling value for the output voltage.

The controlling value for the output voltage, in V, is the value of "Returned value / 1000" (output module V is "Returned value / 100") .

Example of return value	Except output module V Return value:5010 => 5.010V
	Output module V Return value:7520 => 75.20 V

* If the state has changed by volume adjustment, etc., the return value will be different from the value set by "SET_VOUT".

Table 6.3.3 "READ_VOUT_REFERENCE" Operation example (AM06-xxxC)

Operation	Return value	Slot1 Output	Remark
1 Send "SET_VOUT" & "10000"	24000	24.0V	
2 Send "READ_VOUT_PRM"	24000	24.0V	
3 Send "READ_VOUT_REFERENCE"	24000	24.0V	
4 Adjust output voltage to 22.5V by volume	—	22.5V	-1.5V by volume
5 Send "READ_VOUT_PRM"	24000	22.5V	
6 Send "READ_VOUT_REFERENCE"	22500	22.5V	

6.3.5 SET_VOUT_UPPER_LIMIT [17h] [04h] [Argument]**SELECT**

This command sets a upper limit for the output voltage adjustment range.

The upper limit voltage, in V, of the output voltage adjustment range is set to the value of "Argument/10" (output module V is "Argument").

This setting is applied to all operations related to the voltage adjustment (Internal potentiometer, VTRM terminal, "SET_VOUT" command).

The voltage exceeding this upper limit is not outputted even in the constant current operation.

When the specified value is lower than the output voltage, the output voltage changes to the specified value.

It cannot be set to the value which is the lower limit which has been set by "SET_VOUT_LOWER_LIMIT" or less.

It cannot be set to the value which exceeds the upper limit of the output voltage adjustment range.

Example of argument	Except output module V	Argument:241 => 24.1 V
	Output module V	Argument:101 => 101V
Return value	Argument value	

6.3.6 READ_VOUT_UPPER_LIMIT_PRM [1Eh] [09h] [1Bh] [14h]**SELECT**

This command returns the value (argument value) set by "SET_VOUT_UPPER_LIMIT" command.

6.3.7 SET_VOUT_LOWER_LIMIT [17h] [05h] [Argument]**SELECT**

This command sets a lower limit for the output voltage adjustment range.

The lower limit voltage, in V, of the output voltage adjustment range is set to the value of "Argument/10".

This setting is applied to all operations related to the voltage adjustment (Internal potentiometer, VTRM terminal, "SET_VOUT" command).

During the constant current operation, the output voltage may get lower than this value.

It cannot be set to the value which is the upper limit which has been set by "SET_VOUT_UPPER_LIMIT" or more.

Example of argument	Except output module V	Argument:175 => 17.5 V
	Output module V	Argument:65 => 65V
Return value	Argument value	

6.3.8 READ_VOUT_LOWER_LIMIT_PRM [1Eh] [09h] [1Bh] [15h]**SELECT**

This command returns the value (argument value) set by "SET_VOUT_LOWER_LIMIT" command.

6.3.9 SET_VOUT_LIMIT_FACTORY_SETTING [1Eh] [09h] [0Bh] [1Eh]**SELECT**

This command restores the value set by "SET_VOUT_UPPER_LIMIT" and "SET_VOUT_LOWER_LIMIT" to the factory defaults.

Return value	0
--------------	---

The value of the upper and lower limit of the output voltage that have been stored in the non-volatile memory by "SYS_STORE_USER_SETTING" command does not change.

6.4 Commands to set constant current

The target of commands to set the constant current is the output module.

If the front-end module is target, an error is returned.

(Error code 6 : Command that do not correspond to the setting target)

If the instruction is executed on an output module other than the corresponding output modules, an error is returned. (Error code 6 : Command that do not correspond to the setting target)

Modules in parallel cannot be used with the constant current operation. (This command cannot be used for parallel operation.)

6.4.1 SET_CC_MODE_ITRM [1Eh] [09h] [0Ah] [00h]

SELECT

This command makes the value of the constant current be the one which is set by the voltage on the ITRM terminal.

This is the factory default.

Return value	0
--------------	---

6.4.2 SET_CC_MODE_INFO [1Eh] [09h] [0Ah] [01h]

SELECT

This command makes the value of the constant current be the one which is set by "SET_CC" command.

Return value	1
--------------	---

6.4.3 READ_CC_MODE_PRM [1Eh] [09h] [1Ah] [18h]

SELECT

This command returns a setting method of the constant current.

Status	Return value:0 => by ITRM terminal voltage
	Return value:1 => by command SET_CC

6.4.4 SET_CC [0Ch] [Argument]

SELECT

This command sets the value for the constant current.

It sets the value of "Argument/100" to the value, in A, of the constant current.

It cannot be set to the value which exceeds the upper limit that have been set by "SET_CC_UPPER_LIMIT" command.

It cannot be set to the value which exceeds the rated current.

Example of argument	Argument:1350 => 13.50 A
Return value	Argument value

The factory default is that the constant current can be set by the voltage on the ITRM terminal.

The value set by this command get enabled if "SET_CC_MODE_INFO" command is transmitted.

The order of transmitting "SET_CC_MODE_INFO" command and "SET_CC" command is no object.

6.4.5 READ_CC_PRM [1Eh] [09h] [1Ah] [10h]

SELECT

This command returns the value (argument value) set by "SET_CC" command.

6.4.6 SET_CC_FACTORY_SETTING [1Eh] [09h] [0Ah] [1Fh]

SELECT

This command restores the value of the constant current set by "SET_CC" command to the factory default.

Return value	0
--------------	---

The value of the constant current that has been stored in the non-volatile memory by "SYS_STORE_USER_SETTING" command does not change.

6.4.7 READ_CC_REFERENCE [1Eh] [09h] [1Ah] [00h]

SELECT

This command returns the controlling value for the constant current.

Example of return value	Return value:1150 => 11.50A
-------------------------	-----------------------------

* If the state has changed by any protection, etc., the return value will be different from the value set by "SET_CC".

Table 6.4.1 "READ_CC_REFERENCE" Operation example (AM06-xxxF)

Operation	Return value	Slot1 Output	Remark
1 Power on	—	20.0A	Rated output current
2 Send "SET_CC" & "1700"	1700	17.0A	
3 Send "READ_CC_PRM"	1700	17.0A	
4 Send "READ_CC_REFERENCE"	1700	17.0A	
5 Send "SET_CC_UPPER_LIMIT" & "150"	150	15.0A	
6 Send "READ_CC_PRM"	1700	15.0A	
6 Send "READ_CC_REFERENCE"	1500	15.0A	

6.4.8 SET_CC_UPPER_LIMIT [18h] [04h] [Argument]

SELECT

This command sets the upper limit of the setting of the constant current.

The upper limit, in A, for the constant current is set to the value of "Argument/10".

When the specified value is lower than the controlling value of the constant current, the constant current changes to the specified value.

It cannot be set to the value which exceeds the rated current.

Example of argument	Argument:115 => 11.5A
Return value	Argument value

6.4.9 READ_CC_UPPER_LIMIT_PRM [1Eh] [09h] [1Ah] [14h]

SELECT

This command returns the value (argument value) set by "SET_CC_LIMIT" command.

6.4.10 SET_CC_LIMIT_FACTORY_SETTING [1Eh] [09h] [0Ah] [1Eh]

SELECT

This command restores the value set by "SET_CC_LIMIT" command to the factory default.

Return value	0
--------------	---

The upper limit of the constant current that has been stored in the non-volatile memory by "SYS_STORE_USER_SETTING" command does not change.

6.4.11 SET_CC_CONTROL [18h] [09h] [Argument]**SELECT**

This command sets a controlled variable of the constant current.

When the constant current is set by "SET_CC" command, etc, the time to the setting value can be selected.

This setting is enabled under the constant current operation.

The factory default is "0".

Settable range	0, 1, 2, 3, 4
Status	Argument:0 ⇒ Default
	Argument:1 ⇒ Default x 0.2 (Slow)
	Argument:2 ⇒ Default x 2 (Fast)
	Argument:3 ⇒ Default x 4 (Fast)
	Argument:4 ⇒ Default x 28.8 (Very fast)
Return value	Argument value

6.4.12 READ_CC_CONTROL_PRM [1Eh] [09h] [1Ah] [0Ch]**SELECT**

This command returns the value (argument value) set by "SET_CC_CONTROL" command.

6.5 Commands to set output voltage sequence

6.5.1 SET_TON_DELAY_SLOT [0Fh] [Argument]

SELECT

This command sets the value of the delay time, in ms, from when power conversion is ready to when it starts. (See Figure 6.5.1.)

The setting by this command causes a delay due to the processing time of the slave which is the AME series.

This is enabled at AC input with power conversion ready, but the internal delay of up to 800ms occurs.

The factory default is "0".

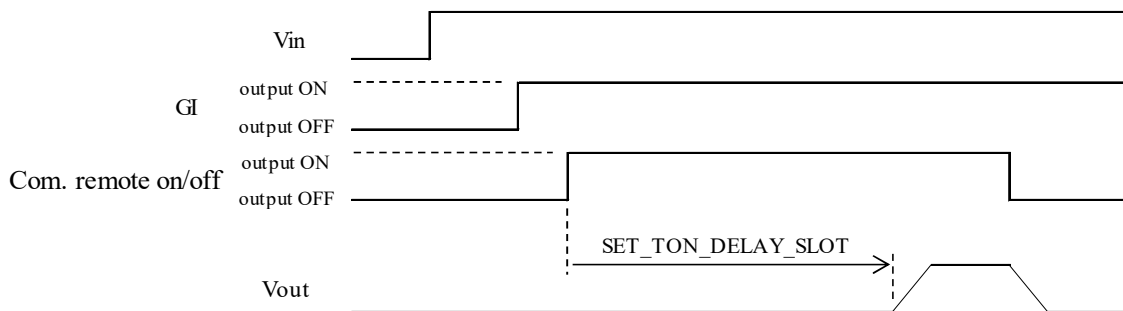

*The power conversion starts after delay time set by "SET_TON_DELAY_SLOT" command when conditions such as AC input, disabling the GI and enabling the Remote ON are met.

Figure 6.5.1 Timing diagram of "SET_TON_DELAY_SLOT"

Settable range	0 - 3000
Example of argument	Argument:900 => 900 msec
Return value	Argument value

No delay time is set for the RC terminal of each output module.

If the front-end module is target, an error is returned.

(Error code 6 : Command that do not correspond to the setting target)

6.5.2 READ_TON_DELAY_SLOT_PRM [1Eh] [09h] [1Dh] [06h]

SELECT

This command returns the value (the argument value) set by "SET_TON_DELAY_SLOT" command.

If the front-end module is target, an error is returned.

(Error code 6 : Command that do not correspond to the setting target)

6.5.3 SET_TON_DELAY_FACTORY_SETTING [1Eh] [09h] [0Dh] [00h]

This command restores the delay time to power-on set by "SET_TON_DELAY_SLOT" command for all slots to the factory default.

Return value	0
--------------	---

The delay time to power-on that has been stored in the non-volatile memory by

"SYS_STORE_USER_SETTING" command does not change.

6.5.4 SET_TOFF_DELAY_SLOT [10h] [Argument]

SELECT

This command sets the value of the delay time, in ms, from when a stop signal which is the GI or the communication signal of the module inhibit is received to when power conversion stops. (See Figure 6.5.2.)

The setting by this command causes a delay due to the processing time of the slave which is the AME series.

The factory default is "0".

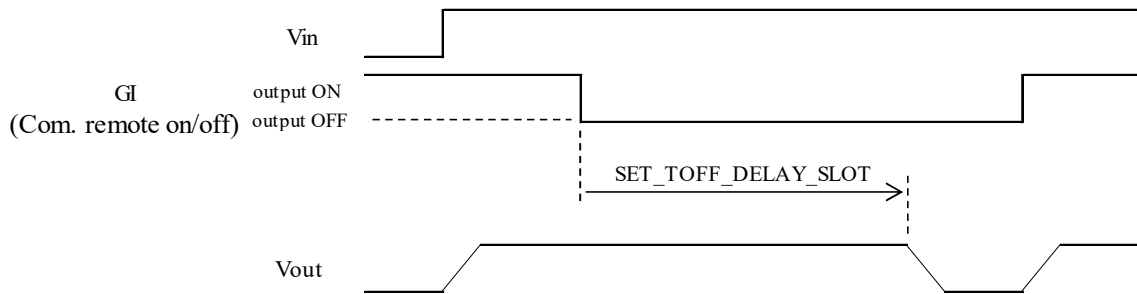

*The power conversion stops after delay time set by "SET_TOFF_DELAY_SLOT" command, when meeting the stop-condition by the GI or communication remote on/off.

Figure 6.5.2 Timing diagram of "SET_TOFF_DELAY_SLOT"

Settable range	0 - 3000
Example of argument	Argument:900 => 900 msec
Return value	Argument value

No delay time is set for the RC terminal of each output module.

No delay time is set under conditions which the power conversion cannot be maintained like the lower input voltage than the stop voltage.

If the front-end module is target, an error is returned.

(Error code 6 : Command that do not correspond to the setting target)

6.5.5 READ_TOFF_DELAY_SLOT_PRM [1Eh] [09h] [1Dh] [07h]

SELECT

This command returns the value (the argument value) set by "SET_TOFF_DELAY_SLOT" command.

If the front-end module is target, an error is returned.

(Error code 6 : Command that do not correspond to the setting target)

6.5.6 SET_TOFF_DELAY_FACTORY_SETTING [1Eh] [09h] [0Dh] [01h]

This command restores the delay time to power-off set by "SET_TOFF_DELAY_SLOT" command for all slots to the factory default.

Return value	0
--------------	---

The delay time to power-off that has been stored in the non-volatile memory by "SYS_STORE_USER_SETTING" command does not change.

6.5.7 SET_TON_DELAY_VIN [0Eh] [Argument]

This command sets the delay time, in ms, from power-on to when power conversion starts. (See Figure 6.5.3.)

The factory default is the value of the specification for the start-up time.

Store the setting value by "SYS_STORE_USER_SETTING" command after this command is transmitted. Then, wait for 30 seconds or more after power-off. The setting will get enabled from next start-up.

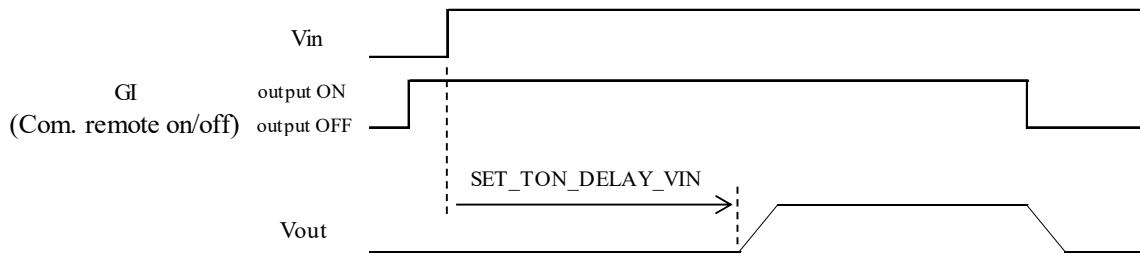
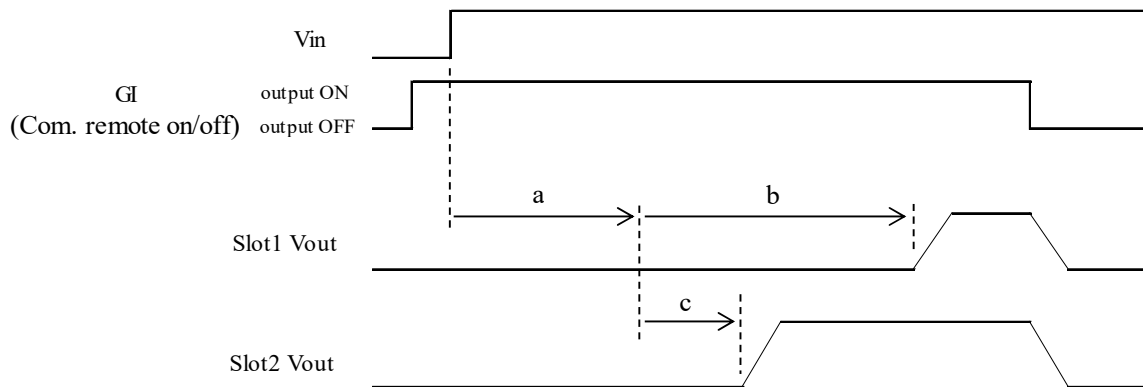

Figure 6.5.3 Timing diagram of "SET_TON_DELAY_VIN"

Settable range	790 - 60000
Example of argument	Argument:900 => 900 msec
Return value	Argument value

When the delay time is set by the SET_TON_DELAY_SLOT command, its operation starts after the one by "SET_TON_DELAY_VIN" command. (See Fig. 6.5.4.)



	SET_TON_DELAY_VIN	SET_TON_DELAY_SLOT
Slot1	a	b
Slot2	a	c

Figure 6.5.4 Timing diagram for "SET_TON_DELAY_SLOT" and "SET_TON_DELAY_VIN"

6.5.8 READ_TON_DELAY_VIN_PRM [1Eh] [09h] [1Dh] [00h]

This command returns the value (argument value) set by "SET_TON_DELAY_VIN" command.

6.5.9 SET_START_UP_VIN_AC [17h] [00h] [Argument]

This command sets the starting voltage for the AC input.

Store the setting value by "SYS_STORE_USER_SETTING" command after this command is transmitted. Then, wait for 30 seconds or more after power-off. The setting will get enabled from next start-up.

With this command, the starting voltage cannot be set to the value which is lower than 5V higher value than the one by "SET_STOP_VIN_AC" command. If specified, this command is not accepted and an error is returned. (Error code 1 : The argument outside settable range is specified.)

Settable range	80 - 240VAC
Example of argument	Argument:170 => 170VAC
Return value	Argument value

When the input voltage is 90VAC or less, load derating is required. Refer the AME series instruction manual for the detail.

6.5.10 READ_START_UP_VIN_AC_PRM [1Eh] [09h] [1Ch] [00h]

This command returns the value (argument value) set by "SET_START_UP_VIN_AC" command.

6.5.11 SET_STOP_VIN_AC [17h] [01h] [Argument]

This command sets the stopping voltage for the AC input.

Store the setting value by "SYS_STORE_USER_SETTING" command after this command is transmitted. Then, wait for 30 seconds or more after power-off. The setting will get enabled from next start-up.

With this command, the starting voltage cannot be set to the value which is higher than 5V lower value than the one by "SET_START_UP_VIN_AC" command. If specified, this command is not accepted and an error is returned. (Error code 1 : The argument outside settable range is specified.)

Settable range	75 - 150VAC
Example of argument	argument:90 => 90VAC
Return value	argument value

When the input voltage is 90VAC or less, load derating is required. Refer the AME series instruction manual for the detail.

6.5.12 READ_STOP_VIN_AC_PRM [1Eh] [09h] [1Ch] [01h]

This command returns the value (argument value) set by "SET_STOP_VIN_AC" command.

6.5.13 SET_RAMP_RATE [1Ah] [03h] [Argument]

SELECT

This command sets a ramp rate of the output voltage.

The setting is enabled for the start-up by power-on or the remote-on" and "the output voltage adjustment by the VTRM terminal or "SET_VOUT" command.

The factory default is "0".

Settable range	0, 1, 2	
Status	Argument:0 ⇒ Default	(Fast)
	Argument:1 ⇒ 10%-90%(rated voltage) / approx.50 msec	(Slow)
	Argument:2 ⇒ 10%-90%(rated voltage) / approx.280 msec	(Very slow)
Return value	Argument value	

If the front-end module is target, an error is returned.

(Error code 6 : Command that do not correspond to the setting target)

If the instruction is executed on an output module other than the corresponding output modules, an error is returned. (Error code 6 : Command that do not correspond to the setting target)

6.5.14 READ_RAMP_RATE_PRM [1Eh] [09h] [1Dh] [03h]

SELECT

This command returns the value (argument value) set by "SET_RAMP_RATE" command.

If the front-end module is target, an error is returned.

(Error code 6 : Command that do not correspond to the setting target)

If the instruction is executed on an output module other than the corresponding output modules, an error is returned. (Error code 6 : Command that do not correspond to the setting target)

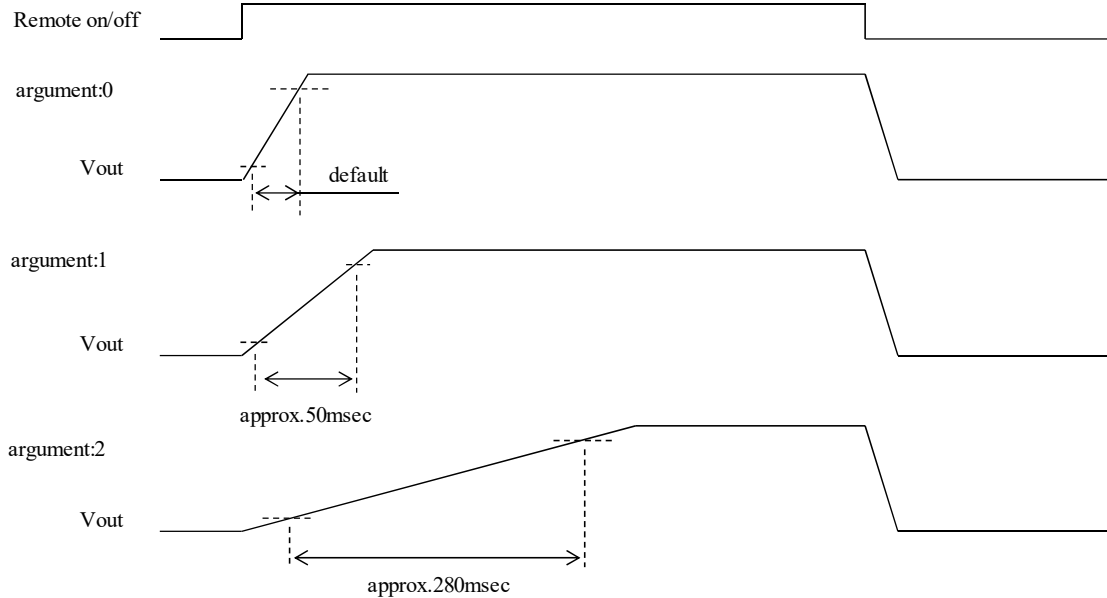

Figure 6.5.5 Activation chart by Remote ON/OFF terminal

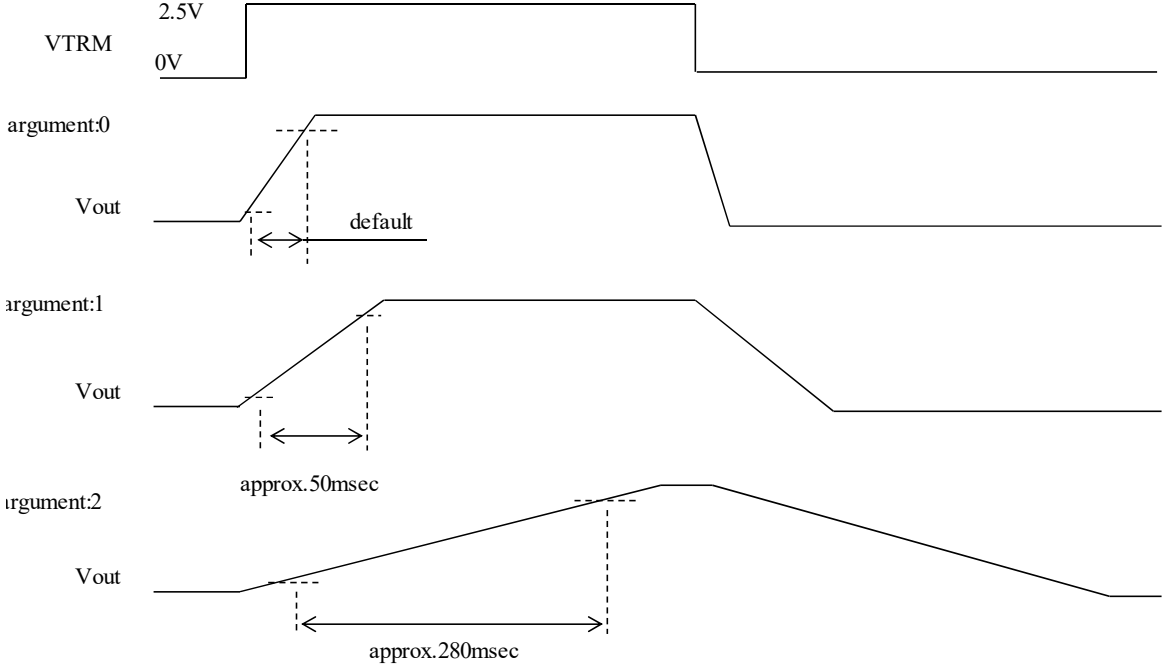

Figure 6.5.6 Activation chart by the VTRM terminal

6.6 Commands to set accessory functions

6.6.1 SET_FAN_MODE_AUTO [1Eh] [09h] [07h] [00h]

This command makes the rotation speed of the built-in air-cooling fan be controlled automatically. This is the factory default.

Return value	0
--------------	---

6.6.2 SET_FAN_MODE_FIXED_SPEED [1Eh] [09h] [07h] [01h]

This command sets the rotation speed of the built-in air-cooling fan to the max value.

Return value	1
--------------	---

6.6.3 READ_FAN_MODE_PRM [1Eh] [09h] [17h] [00h]

This command returns the setting for the rotation-speed control of the built-in air-cooling fan.

Status	Return value:0 =>	Automatic control (Variable speed)
	Return value:1 =>	Fixed speed

6.6.4 SET_AUX_VOUT [17h] [10h] [Argument]

This command sets the output voltage for the AUX power.

It sets the value of "Argument / 10" to the AUX output voltage, in V. The factory default is 5V.

Settable range	4.7 - 12.6V
Example of argument	Argument:50 => 5.0V
Return value	Argument value

The rated output current of AUX changes with the output voltage. (See Figure 6.6.1.)

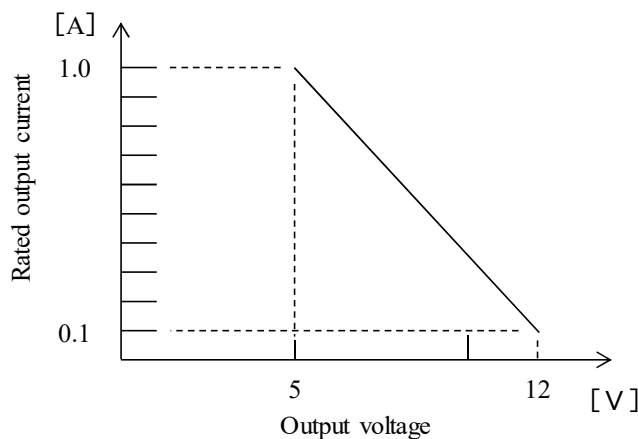

Figure 6.6.1 The rated output current of AUX (AME series)

6.6.5 READ_AUX_VOUT_PRM [1Eh] [09h] [18h] [00h]

This command returns the value (argument value) set by "SET_AUX_VOUT" command.

6.6.6 SET_VIN_LV_ALARM [16h] [18h] [Argument]

This command sets the input threshold voltage for the alarm signal from PR terminal.
 It sets the argument to the input voltage, in V, for the alarm signal which detects lower input voltage.

Settable range	75 - 240V
Example of argument	Argument:95 => 95V
Return value	Argument value

6.6.7 READ_VIN_LV_ALARM_PRM [1Eh] [09h] [1Eh] [03h]

This command returns the value (argument value) set by "SET_VIN_LV_ALARM" command.

6.6.8 SET_PR_TERMINAL_MODE_PR [1Eh] [09h] [0Eh] [08h]

This command sets the PR terminal to work for the abnormal detection (PR alarm function).
 This is the factory default.

Return value	0
--------------	---

6.6.9 SET_PR_TERMINAL_MODE_PG [1Eh] [09h] [0Eh] [09h]

This command setting the PR terminal to work for the detection of the front-end module stoppage (PG alarm function).

Return value	1
--------------	---

6.6.10 READ_PR_TERMINAL_MODE_PRM [1Eh] [09h] [1Eh] [0Dh]

This command returns a status of the detection function in the PR terminal.

Status	Return value:0 => PR alarm function
	Return value:1 => PG alarm function

6.6.11 SET_ALARM_STATUS [16h] [19h] [Argument]

This command sets the abnormal conditions in which an alarm signal is output from the PR terminal, by the argument.

The relationship between the argument (binary) and abnormal conditions is shown below.

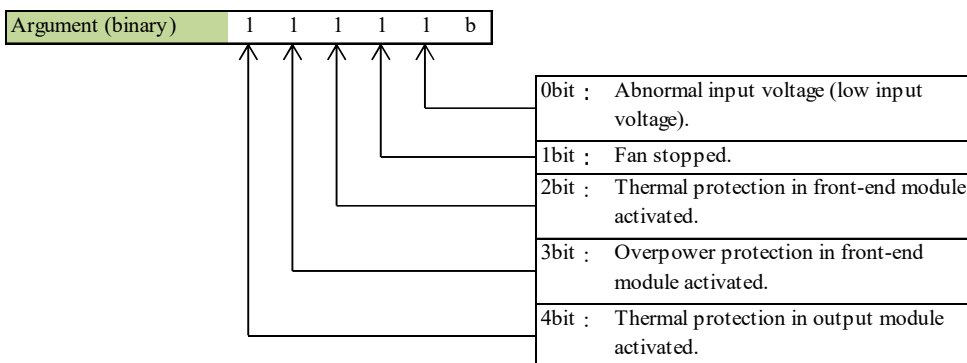

The factory default of the argument is "00011b" (Abnormal input voltage and fan stoppage).

Status	Return value:1 => Output alarm signal
	Return value:0 => Do not output alarm signal
Settable range	00000 - 11111b
Example of argument	argument:10100b => An alarm signal outputs when the thermal protection in the front-end or output module activates.
Return value	argument value

6.6.12 READ_ALARM_STATUS_PRM [1Eh] [09h] [1Eh] [04h]

This command returns the value (argument value) set by "SET_ALARM_STATUS" command.

6.6.13 SET_VOUT_LV_ALARM [16h] [1Bh] [Argument]

SELECT

This command sets the threshold voltage for the alarm signal from LV terminal at when the output voltage drops.

It sets the value of "Argument / 10" (output module V is "Argument") to the output threshold voltage, in V, for the alarm signal from the LV terminal.

With this command, it can not be set to higher value than the calculation below.

Calculation: Value set by "SET_VOUT_HV_ALARM" command - 20% of Rated voltage

Settable range	Rated voltage x 5% - Rated voltage x 180% (The maximum value for output modules U and 2M is 58.3 V, while the maximum value for output modules U, H, and H4 is 55.9 V)
Example of argument	Except output module V Argument:35 => 3.5 V
	Output module V Argument:55 => 55V
Return value	argument value

If the front-end module is target, an error is returned.

(Error code 6 : Command that do not correspond to the setting target)

If the instruction is executed on an output module other than the corresponding output modules, an error is returned.(Error code 6 : Command that do not correspond to the setting target)

6.6.14 READ_VOUT_LV_ALARM_PRM [1Eh] [09h] [1Bh] [1Eh]

SELECT

This command returns the value (argument value) set by "SET_VOUT_LV_ALARM" command.

If the front-end module is target, an error is returned.

(Error code 6 : Command that do not correspond to the setting target)

If the instruction is executed on an output module other than the corresponding output modules, an error is returned.(Error code 6 : Command that do not correspond to the setting target)

6.6.15 SET_VOUT_HV_ALARM [16h] [1Ch] [Argument]

SELECT

This command sets the threshold voltage for the alarm signal from LV terminal at when the output voltage rises.

It sets the value of "Argument / 10" (output module V is "Argument") to the output threshold voltage, in V, for the alarm signal from the LV terminal.

With this command, it can not be set to lower value than the calculation below.

Calculation: Value set by "SET_VOUT_LV_ALARM" command + 20% of Rated voltage

Settable range	Rated voltage x 25% - Rated voltage x 200% (The maximum value for output modules U, H, and H4 is 65.5V.)
Example of argument	Except output module V Argument:520 => 52.0 V
	Output module V Argument:105 => 105V
Return value	argument value

If the front-end module is target, an error is returned.

(Error code 6 : Command that do not correspond to the setting target)

If the instruction is executed on an output module other than the corresponding output modules, an error is returned.(Error code 6 : Command that do not correspond to the setting target)

6.6.16 READ_VOUT_HV_ALARM_PRM [1Eh] [09h] [1Bh] [1Fh]

SELECT

This command returns the value (argument value) set by "SET_VOUT_HV_ALARM" command.

If the front-end module is target, an error is returned.

(Error code 6 : Command that do not correspond to the setting target)

If the instruction is executed on an output module other than the corresponding output modules, an error is returned.(Error code 6 : Command that do not correspond to the setting target)

6.6.17 SET_VOUT_ALARM_FACTORY_SETTING

SELECT

[1Eh] [09h] [0Bh] [1Dh]

This command sets the value set by "SET_VOUT_LV_ALARM" command and "SET_VOUT_HV_ALARM" command to the factory default.

Return value	0
--------------	---

If the front-end module is target, an error is returned.

(Error code 6 : Command that do not correspond to the setting target)

If the instruction is executed on an output module other than the corresponding output modules, an error is returned.(Error code 6 : Command that do not correspond to the setting target)

6.7 Monitor commands

6.7.1 MON_VIN [1Eh] [08h] [00h] [01h]

This command returns the RMS value of the input voltage. It discriminates DC from AC automatically. The input voltage, in V, is the value of "Return value /100".
 If the input voltage was distorted, the return value may not be correct.

Example of return value	Return value:24010 => AC240.10V
-------------------------	---------------------------------

6.7.2 MON_VIN_FREQUENCY [1Eh] [08h] [00h] [1Fh]

This command returns the frequency of the input voltage.
 The frequency, in Hz, of the input voltage is the value of "Returned value / 10". When the input is "DC", the return value is "0".
 It will be unsettled for five seconds from power-on.

Example of return value	Return value:481 => 48.1Hz
-------------------------	----------------------------

6.7.3 MON_VOUT [1Eh] [08h] [01h] [00h]

SELECT

This command returns the output voltage (voltage between the output terminals).
 The output voltage, in V, is the value of "Returned value / 1000" (output module V is "Returned value / 100").

Example of return value	Return value:24200 => 24.200V
-------------------------	-------------------------------

If the front-end module is targeted, an error is returned.
 (Error code 6 : Command that do not correspond to the setting target)
 If the instruction is executed on an output module other than the corresponding output modules, an error is returned.(Error code 6 : Command that do not correspond to the setting target)

6.7.4 MON_IOUT [1Eh] [08h] [05h] [00h]

SELECT

This command returns the output current.
 The output current, in A, is the value of "Returned value / 100".

Example of return value	Return value:1350 => 13.50A
-------------------------	-----------------------------

If the front-end module is targeted, an error is returned.
 (Error code 6 : Command that do not correspond to the setting target)
 If the instruction is executed on an output module other than the corresponding output modules, an error is returned.(Error code 6 : Command that do not correspond to the setting target)

6.7.5 MON_OUTPUT_POWER [1Eh] [08h] [08h] [10h]

SELECT

This command returns the output power.
 The output power, in W, is the value of "Returned value / 10".

Example of return value	Return value:6000 => 600.0W
-------------------------	-----------------------------

If the front-end module is targeted, an error is returned.
 (Error code 6 : Command that do not correspond to the setting target)
 If the instruction is executed on an output module other than the corresponding output modules, an error is returned.(Error code 6 : Command that do not correspond to the setting target)

6.7.6 MON_FAN_SPEED_1 [1Eh] [08h] [0Ch] [00h]

This command returns the fan speed of the internal air-cooling fan 1. The fan speed, in rpm, is the return value.

Example of return value	Return value:7500 => 7500rpm
-------------------------	------------------------------

6.7.7 MON_FAN_SPEED_2 [1Eh] [08h] [0Ch] [01h]

This command returns the fan speed of the internal air-cooling fan 2. The fan speed, in rpm, is the return value.

Example of return value	Return value:7500 => 7500rpm
-------------------------	------------------------------

When this command is transmitted to AME400F or AME600F, the return value is "0".

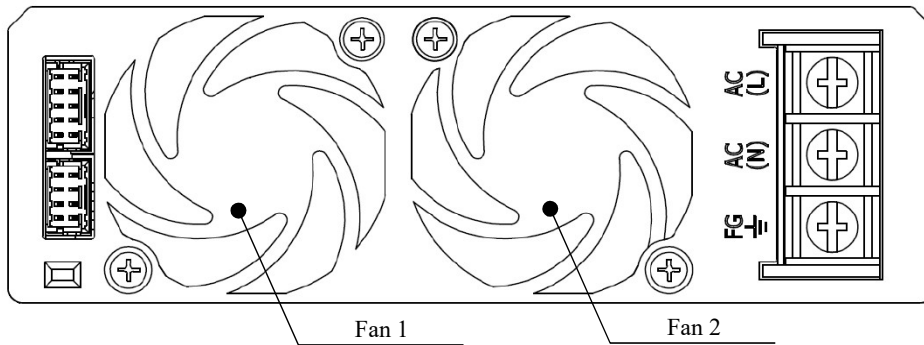

Figure 6.7.1 Position of fans in AME800F or AME1200F (Front view)

6.7.8 MON_AUX_VOUT [1Eh] [09h] [18h] [01h]

This command returns the AUX output voltage. The AUX output voltage, in V, is the value "Returned value / 1000".

Example of return value	Return value:5100 => 5.100V
-------------------------	-----------------------------

6.7.9 MON_TEMPERATURE_1 [1Eh] [08h] [0Eh] [00h]

This command returns the temperature near the fan in the unit. The temperature, in °C, is the returned value (signed hexadecimal number).

Range	-30 ~ 100°C
Examples of return value	Return value: "0000 0000 0001 1001" => +25°C
	Return value: "1111 1111 1110 0111" => -25°C

6.8 State acquisition commands

6.8.1 READ_STOP_CODE [1Eh] [09h] [1Eh] [10h]

SELECT

This command returns the code indicating the cause of the stoppage.

SET_SELECTION_CH setting target	Stop code	Cause of stop
Front-end module (Set value: 0)	000	No stoppage occurred.
	003	Global inhibit is activating.
	010	Stoppage due to input voltage drop.
	054	Stoppage due to abnormal fan rotation.
	062	Stoppage by overpower protection in front-end module.
	106	Stoppage by thermal protection.
	130	Stoppage by overvoltage or thermal protection in the output module.
	131	module.
Output module (Set value: 1-6)	000	No stoppage occurred.
	001	Stoppage by RC terminal.
	013	Stoppage by command from input module. (Module inhibit by communication, etc.)
	050	
	051	Stoppage by activation of overcurrent protection.
	071	

If the stop code is not listed above, the unit may be failure.

If the output module is stopped due to an input module stop, the command to the slot will be error. (Error code 8449 : Internal communication error)

If the instruction is executed on an output module other than the corresponding output modules, an error is returned. (Error code 6 : Command that do not correspond to the setting target)

6.8.2 READ_PR_ALARM [1Eh] [08h] [14h] [01h]

This command returns the PR alarm status. (alarm for abnormal conditions)

The relationship between the return value (binary) and abnormal conditions is shown below.

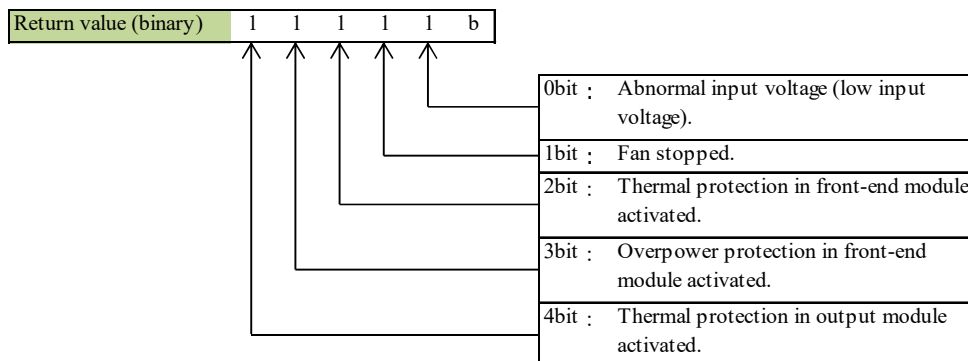

Status	Return value:0 => Normal operation
	Return value:1 => Abnormal operation

Return value	Return value : 00010b => Fan stopped
	Return value : 00011b => Low input voltage and fan stopped

6.8.3 READ_PG_ALARM [1Eh] [08h] [14h] [02h]

This command returns the PG alarm status. (Alarm for input module stoppage).

Status	Return value:0 => Normal operation
	Return value:1 => Input module stopped

6.8.4 READ_LV_ALARM [1Eh] [08h] [14h] [00h]

SELECT

This command returns the LV alarm status. (Alarm for output voltage failure).

Status	Return value:0 => Normal operation
	Return value:1 => Output voltage drop
	Return value:2 => Output voltage rise

If the front-end module is targeted, an error is returned.

(Error code 6 : Command that do not correspond to the setting target)

If the instruction is executed on an output module other than the corresponding output modules, an error is returned.(Error code 6 : Command that do not correspond to the setting target)

6.8.5 TOTAL_INPUT_TIME

This command returns the accumulated time for application of the input voltage stored in the non-volatile memory of the AME.

The returned value of "TOTAL_INPUT_TIME_1" represents "minute" and it is reset to "0" every 60 minutes.

The returned value of "TOTAL_INPUT_TIME_2" represents low 16 bits and the one of "TOTAL_INPUT_TIME_3" represents high 16 bits. And, those 32 bits are returned as the accumulated time for the application of the input voltage, in hour.

The data may not be stored for less than one minute before power-off.

TOTAL_INPUT_TIME_1 [1Eh] [08h] [10h] [00h]

Range	0 ~ 59 minute
Example of return value	Return value:57 => 57 minute

TOTAL_INPUT_TIME_2 [1Eh] [08h] [10h] [01h]

TOTAL_INPUT_TIME_3 [1Eh] [08h] [10h] [02h]

Range	0 ~ 2 ³² -1 hour (Theoretical value)	
Constitution	Low 16 bits	:TOTAL_INPUT_TIME_2 (0~65,535hour)
	High 16 bits	:TOTAL_INPUT_TIME_3

SELECT

6.8.6 TOTAL_OUTPUT_TIME

This command returns the accumulated time for outputs stored in the non-volatile memory of the AME.

If the front-end module is selected, the accumulated time for output of the front-end module is returned.

If a slot is selected, the accumulated time for output of the output module is returned.

The returned value of "TOTAL_OUTPUT_TIME_1" represents "minute" and it is reset to "0" every 60 minutes.

The returned value of "TOTAL_OUTPUT_TIME_2" represents low 16 bits and the one of "TOTAL_OUTPUT_TIME_3" represents high 16 bits. And, those 32 bits are returned as the accumulated time for the application of the input voltage, in hour.

The data may not be stored for less than one minute before power-off.

TOTAL_OUTPUT_TIME_1 [1Eh] [08h] [11h] [00h]

Range	0 ~ 59 minute
Example of return value	Return value:57 ⇒ 57 minute

TOTAL_OUTPUT_TIME_2 [1Eh] [08h] [11h] [01h]**TOTAL_OUTPUT_TIME_3 [1Eh] [08h] [11h] [02h]**

Range	0 ~ $2^{32}-1$ hour (Theoretical value)
Constitution	Low 16 bits :TOTAL_INPUT_TIME_2 (0~65,535hour)
	High 16 bits :TOTAL_INPUT_TIME_3

If the instruction is executed on an output module other than the corresponding output modules, an error is returned.(Error code 6 : Command that do not correspond to the setting target)

6.9 Commands to set address, memory, and communication

6.9.1 SET_SELECTION_CH [1Ah] [1Ch] [Argument]

By selecting the input module or target slot with this command and sending the corresponding command, it is possible to set the selected target and return the setting status.

The factory default is the front-end module.

The following symbol mark is displayed on commands that assume input of this command.

SELECT

Example:

6.9.2 READ_SELECTION_CH [1Eh] [09h] [1Fh] [00h] **SELECT**
Returns the target selected by the command SET_SELECTION_CH.

The command corresponding to this command is shown below.

SET_SELECTION_CH Corresponding commands	
6.2 Commands to turn output voltage on/off	
5 CTL_REMOTE_ON_CH	:Turn ON the output voltage
6 CTL_REMOTE_OFF_CH	:Turn OFF the output voltage
8 READ_REMOTE_PRM	:Returns the output ON / OFF setting status by communication
9 READ_REMOTE_CONTROL	:Returns the output ON / OFF setting status
6.3 Commands to set output voltage	
(All commands)	:Send command to selection
6.4 Commands to set constant current	
(All commands)	:Send command to selection
6.5 Commands to set output voltage sequence	
1 SET_TON_DELAY_SLOT	:Set the startup delay time from output ON
2 READ_TON_DELAY_SLOT_PRM	:Returns the set value of the startup delay time from output ON
4 SET_TOFF_DELAY_SLOT	:Set stop delay time from output OFF
5 READ_TOFF_DELAY_SLOT_PRM	:Returns the set value of stop delay time from output OFF
13 SET_RAMP_RATE	:Select the output voltage change rate
14 READ_RAMP_RATE_PRM	:Returns the rate of change of output voltage
6.6 Commands to set accessory functions	
13 SET_VOUT_LV_ALARM	:Sets the voltage to output an alarm signal when the output voltage drops
14 READ_VOUT_LV_ALARM_PRM	:Returns the voltage at which an alarm signal is output when the output voltage drops
15 SET_VOUT_HV_ALARM	:Set the voltage to output an alarm signal when the output voltage rises
16 READ_VOUT_HV_ALARM_PRM	:Returns the voltage at which an alarm signal is output when the output voltage rises
17 SET_VOUT_ALARM_FACTORY_SETTING	:Return the output voltage to output the alarm signal to the factory default
6.7 Monitor commands	
3 MON_VOUT	:Returns the output voltage
4 MON_IOUT	:Returns the output current
5 MON_OUTPUT_POWER	:Returns the output power
6.8 State acquisition commands	
1 READ_STOP_CODE	:Returns the code indicating the cause of the stop
4 READ_LV_ALARM	:Returns the LV alarm status
6 TOTAL_OUTPUT_TIME	:Returns the cumulative output time

SET_SELECTION_CH Corresponding commands	
6.9 Commands to set address, memory, and communication	
2	READ_SELECTION_CH :Returns the selected target
6	SYS_STORE_USER_SETTING :Record settings in internal nonvolatile memory
7	SYS_RESTORE_FACTORY_SETTING :Reset settings to factory default
8	READ_STORE_USER_SETTING :Returns the setting recording status in the internal nonvolatile memory
6.10 Commands to acquire product information	
4	READ_PRODUCT_INFO :Returns module information
5	READ_RATED_VOUT :Returns the rated voltage
6	READ_RATED_IOUT :Returns the rated current
8	READ_VOUT_POINT :Returns the decimal point position of the return value from MON_VOUT command.

Specified range	AME400F,AME600F : 0 - 4 AME800F,AME1200F : 0 - 6
Examples of argument	Argument:0 => Set target to input module
	Argument:1 => Set target to slot 1
	Argument:2 => Set target to slot 2
	Argument:3 => Set target to slot 3
	Argument:4 => Set target to slot 4
	Argument:5 => Set target to slot 5
Argument:6 => Set target to slot 6	
Return value	Argument value

If specified to only an empty slot, this command is not accepted and an error is returned. (Error code 5 : The command to the empty slot is transmitted.)

Some commands based on the input of this command may or may not be supported depending on the output module. Refer to "Appendix 2. Support and precision" for availability.

6.9.2 READ_SELECTION_CH [1Eh] [09h] [1Fh] [00h]

SELECT

This command returns the target selected by "SET_SELECTION_CH" command.

Return value	Return value : 0 => Input module is selected.
	Return value : 4 => Slot4 is selected.

6.9.3 SET_WRITE_PROTECT_ON [1Eh] [09h] [05h] [01h]

This command disables the Write command. (See Table 6.1.)

As an exception, "SET_WRITE_PROTECT_OFF" command, "SYS_STORE_USER_SETTING" command" and "CTL_ACCUMULATE_EXEC" command are accepted.

Return value	1
--------------	---

6.9.4 SET_WRITE_PROTECT_OFF [1Eh] [09h] [05h] [02h]

This command disables the protection set by "SET_WRITE PROTECT_ON" command.

This is the factory default.

Return value	0
--------------	---

6.9.5 READ_WRITE_PROTECT_PRM [1Eh] [09h] [15h] [00h]

This command returns the status of WRITE PROTECTION.

Status	Return value:0 => WRITE PROTECTION is disabled.
	Return value:1 => WRITE PROTECTION is enabled.

Table 6.9.1 "SET_WRITE_PROTECT_ON" Operation example (AME series)

Operation	Return value	AME Output
1 Power-on	-	ON
2 Send "CTL_REMOTE_OFF"	0	OFF
3 Send "SET_WRITE_PROTECT_ON"	1	OFF
4 Send "CTL_REMOTE_ON"	224 *	OFF
5 Send "SET_WRITE_PROTECT_OFF"	0	OFF
6 Send "CTL_REMOTE_ON"	1	ON

*Error code 224 : The specified command is not valid.

6.9.6 SYS_STORE_USER_SETTING [1Eh] [09h] [00h] [10h]

SELECT

This command stores value and/or settings set by the communication function in the non-volatile memory of the AME.

Stored values and settings can remain even during power-off.

This command stores settings of target module selected by "SET_SELECTION_CH" command in non-volatile memory of each module.

This command needs to be executed to every target module individually.

Commands corresponding to this command are shown below.

SET_SELECTION_CH Setting target	SYS_STORE_USER_SETTING Supported commands
Input module (Set value: 0)	CTL_REMOTE_XX :Output ON / OFF setting status by communication
	CTL_CH_REMOTE_XX :Output ON / OFF setting status by communication
	CTL_REMOTE_XX_CH :Output ON / OFF setting status by communication
	CTL_POWER_XX_GI :Global inhibit setting by communication
	SET_GI_TERMINAL_MODE_GI :GI terminal setting mode
	SET_GI_TERMINAL_MODE_RC :GI terminal setting mode
	SET_TON_DELAY_SLOT :Delay time from the output voltage is turned on
	SET_TOFF_DELAY_SLOT :Delay time from the output voltage is turned off
	SET_TON_DELAY_VIN :Delay time from input
	SET_START_UP_VIN_AC :start-up input voltage (AC)
	SET_STOP_VIN_AC :stop input voltage (AC)
	SET_FAN_MODE_AUTO :Rotational speed control mode of air cooling fan
	SET_FAN_MODE_FIXED_SPEED :Rotational speed control mode of air cooling fan
	SET_AUX_VOUT :AUX output voltage setting
	SET_VIN_LV_ALARM :Input voltage to output alarm signal
	SET_PR_TERMINAL_MODE_PR :PR terminal setting mode
	SET_PR_TERMINAL_MODE_PG :PR terminal setting mode
	SET_ALARM_STATUS :Setting of abnormal condition to output alarm signal
	SET_WRITE_PROTECT_XX :the current write-protection mode
	CTL_ACCUMULATE_MODE_XX :setting status of the accumulate mode
SET_ADDRESS :setting the communication address	

XX = ON or OFF.

SET_SELECTION_CH Setting target	SYS_STORE_USER_SETTING Supported commands	
Output module (Set value: 1-6)	SET_VOUT	:Output voltage setting
	SET_VOUT_UPPER_LIMIT	:Variable upper limit of output voltage
	SET_VOUT_LOWER_LIMIT	:Variable lower limit of output voltage
	SET_CC_MODE_ITRM	:Constant current setting mode
	SET_CC_MODE_INFO	:Constant current setting mode
	SET_CC	:Constant current operating value
	SET_CC_UPPER_LIMIT	:Upper limit of constant current operating value
	SET_CC_CONTROL	:Control amount for constant current operation
	SET_RAMP_RATE	:Output voltage change rate
	SET_VOUT_LV_ALARM	:Output voltage to output alarm signal
	SET_VOUT_HV_ALARM	:Output voltage to output alarm signal

Return value	1
--------------	---

Note: SET_TON_DELAY_SLOT, SET_TON_DELAY_VIN, SET_TOFF_DELAY_SLOT is the input module setting items. If you want to save, select the input module.

If the instruction is executed on an output module other than the corresponding output modules, an error is returned. (Error code 6 : Command that do not correspond to the setting target)

Multiple items are stored at the same time.

However, the values set after transmitting this command will not be recorded.

The input should not be turned off for at least five seconds after this command is transmitted.

Otherwise, it may not properly be recorded in the non-volatile memory.

Do not transmit "SYS_RESTORE_FACTORY_SETTING" command and this command continuously within 5 seconds. If the process is not completed, this command is not accepted and an error is returned. (Error code 4 : The state of the internal process is busy.)

6.9.7 SYS_RESTORE_FACTORY_SETTING [1Eh] [09h] [01h] [1Fh]

SELECT

This command restore values and settings in the non-volatile memory of the AME stored by "SYS_STORE_USER_SETTING" command to the factory defaults.

Return value	0
--------------	---

This command stores settings of target module selected by "SET_SELECTION_CH" command in non-volatile memory of each module.

This command needs to be executed to every target module individually.

Even if this command is sent, the setting will not return to the factory default while the input voltage is being applied.

When the input voltage is turned off after transmitting this command, the factory default will be restored after turning the input on.

The input should not be turned off for at least five seconds after this command is transmitted.

Otherwise, it may not properly be recorded in the nonvolatile memory.

Do not transmit "SYS_STORE_USER_SETTING" command and this command continuously within 5 seconds. If the process is not completed, this command is not accepted and an error is returned. (Error code 4 : The state of the internal process is busy.)

Table 6.9.2 "SYS_STORE_USER_SETTING" Operation example 1 (AM6-BBBB)

Operation	Return value	ON/OFF setting *1	Remark
1 Power on	-	11111b	
2 Send "CTL_CH_REMOTE_OFF" & "11010b"	11010b	00100b	
3 Send "SET_SELECTION_CH" & "0"	0	00100b	Select Input module
4 Send "SYS_STORE_USER_SETTING"	1	00100b	
5 Input voltage off	-	-	
6 Input voltage on	-	00100b	
7 Send "SET_SELECTION_CH" & "0"	0	00100b	Select Input module
8 Send "SYS_RESTORE_FACTORY_SETTING"	0	00100b	
9 Input voltage off	-	-	
10 Input voltage on	-	11111b	

*1 When confirmed by the READ_REMOTE_CH_PRM command

Table 6.9.3 "SYS_STORE_USER_SETTING" Operation example 2 (AM6-BBBB)

Operation	Return value	Slot1 Output	Remark
1 Power on	-	12.0V	
2 Send "SET_SELECTION_CH" & "1"	1	12.0V	Select slot 1
3 Send "SET_VOUT" & "10000"	10000	10.0V	
4 Send "SYS_STORE_USER_SETTING"	1	10.0V	
5 Input voltage off	-	0V	
6 Input voltage on	-	10.0V	
7 Send "SET_SELECTION_CH" & "2"	2	10.0V	Select slot 2
8 Send "SYS_RESTORE_FACTORY_SETTING"	0	10.0V	
9 Input voltage off	-	0V	
10 Input voltage on	-	10.0V	
11 Send "SET_SELECTION_CH" & "1"	1	10.0V	Select slot 1
12 Send "SYS_RESTORE_FACTORY_SETTING"	0	10.0V	
13 Input voltage off	-	0V	
14 Input voltage on	-	12.0V	

6.9.8 READ_STORE_USER_SETTING [1Eh] [09h] [1Eh] [00h]

SELECT

This command returns the recording status of the settings in the nonvolatile memory inside the AME.

Return value	Return value : 0 => factory default
	Return value : 1 => Settings are recorded

If the instruction is executed on an output module other than the corresponding output modules, an error is returned. (Error code 6 : Command that do not correspond to the setting target)

6.9.9 CTL_ACCUMULATE_MODE_ON [1Eh] [08h] [1Ch] [10h]

This command enables the Accumulate mode. The Accumulate mode means that Write command (Refer to Table 6.1) will not be executed immediately.

As an exception, "CTL_ACCUMULATE_EXEC" command and "CTL_ACCUMULATE_CLER" command are immediately executed.

Return value	1
--------------	---

In the Accumulate mode, the Write command is buffered internally and is not immediately reflected in the product operation. When transmitting "CTL_ACCUMULATE_EXEC" command, the command in the buffer will be reflected in the operation.

Only one command can be held because the buffer is overwritten.

Because no internal processing is performed at the time of buffering, any software errors (see Section 4.7) other than checksum errors are not returned.

The contents of the buffer are not stored in the non-volatile memory.

6.9.10 CTL_ACCUMULATE_MODE_OFF [1Eh] [08h] [1Ch] [11h]

This command disables the Accumulate mode.

This is the factory default.

Return value	0
--------------	---

6.9.11 READ_ACCUMULATE_MODE [1Eh] [08h] [1Ch] [12h]

This command returns the setting status of the Accumulate mode.

Status	Return value:0 =>	Disables the Accumulate mode
	Return value:1 =>	Activates the Accumulate mode

6.9.12 CTL_ACCUMULATE_EXEC [1Eh] [08h] [1Ch] [13h]

When the Accumulate mode is enabled, the contents in the buffer are executed by sending this command. The return value is the one by the buffered command.

"1Eh" indicating this command is returned for the identifier information.

If this command was transmitted with the buffer empty, an error will be returned.

Return value	That of the buffered command
--------------	------------------------------

6.9.13 CTL_ACCUMULATE_CLEAR [1Eh] [08h] [1Ch] [14h]

This command deletes contents in the buffer.

Return value	0
--------------	---

Table 6.9.3 "CTL_ACCUMULATE_MODE_ON" Operation example (AME series)

Operation	Return value	AME Output
1 Input voltage on	-	ON
2 Send "CTL_REMOTE_OFF"	0	OFF
3 Send "CTL_ACCUMULATE_MODE_ON"	1	OFF
4 Send "CTL_REMOTE_ON"	1	OFF
5 Send "READ_REMOTE_PRM"	0	OFF
6 Send "CTL_ACCUMULATE_EXEC"	1	ON

6.9.14 SET_ADDRESS [1Ah] [10h] [Argument]

This command selects the setting method of the communication address and the address.

It sets the communication address to the value specified by the argument.

However, when the argument is "128", the address becomes the value specified by the ADDR terminal.

The address of the reply packet is that specified by this command.

The factory default is "128" which means setting by the ADDR terminal.

Specified range	1 - 7, 128
Examples of argument	Argument:1 => Address is 1
	Argument:128 => Corresponds to the ADDR terminal setting

6.9.15 READ_ADDRESS_PRM [1Eh] [09h] [19h] [10h]

This command returns the value (argument value) set by "SET_ADDRESS" command.

6.9.16 READ_ADDRESS [1Eh] [09h] [19h] [00h]

This command returns current communication address.

Range	1 - 7
-------	-------

6.10 Commands to acquire product information

6.10.1 READ_SERIAL [1Eh] [09h] [10h] [00h]

This command returns the product-specific serial number in the lot.

Range	000 - 999
-------	-----------

6.10.2 READ_LOT_H [1Eh] [09h] [10h] [01h]

This command returns the upper three digits of the product lot number.

Range	001 - 954
-------	-----------

6.10.3 READ_LOT_L [1Eh] [09h] [10h] [02h]

This command returns the lower four digits of the product lot number.

Range	0000 - 9999
-------	-------------

6.10.4 READ_PRODUCT_INFO [1Eh] [00h] [07h] [10h]

SELECT

This command returns the information of the selected module.

If a front-end module was selected, the input module information is returned.

If a slot was selected, the information of the output module in the selected slot is returned.

Examples of return value	Return value:400	=>	Input module:AME400F
	Return value:600	=>	Input module:AME600F
	Return value:800	=>	Input module:AME800F
	Return value:1200	=>	Input module:AME1200F
	Return value:12003	=>	Output module:J
	Return value:12005	=>	Output module:A
	Return value:12007	=>	Output module:K
	Return value:12012	=>	Output module:B
	Return value:12015	=>	Output module:L
	Return value:12024	=>	Output module:C
	Return value:12036	=>	Output module:M
	Return value:12048	=>	Output module:D
	Return value:24005	=>	Output module:E, E4
	Return value:24007	=>	Output module:S
	Return value:24012	=>	Output module:F, F4
	Return value:24015	=>	Output module:T
	Return value:24024	=>	Output module:G, G4
	Return value:24036	=>	Output module:U
	Return value:24048	=>	Output module:H, H4
	Return value:24075	=>	Output module:V, V4, V5
Return value:30012	=>	Output module:2B	
Return value:30015	=>	Output module:2L	
Return value:30024	=>	Output module:2C	
Return value:30036	=>	Output module:2M	
Return value:30048	=>	Output module:2D	

Note: Output module E4 to H4, V4, and V5 have the same value from output module E to H and V, respectively.

Examples of return value	Return value:1212	=>	Output module:P
	Return value:1515	=>	Output module:Q
	Return value:2424	=>	Output module:R
	Return value:0	=>	blank

6.10.5 READ_RATED_VOUT [1Eh] [09h] [11h] [00h]

SELECT

This command returns the rated voltage of the selected model.

The output voltage, in V, is set to the value of "Returned value / 1000" (output module V is "Argument/100").

Examples of return value	Except output module V	Return value:12000 => 12 V
	Output module V	Return value:7500 => 75 V

If the front-end input module is target, an error is returned.

(Error code 6 : Command that do not correspond to the setting target)

If the instruction is executed on an output module other than the supported output modules, an error is returned.(Error code 6 : Command that do not correspond to the setting target)

6.10.6 READ_RATED_IOUT [1Eh] [09h] [11h] [01h]

SELECT

This command returns the rated current of the selected model.

The rated output current is set to the value of "Returned value / 100".

Examples of return value	Return value : 1200	=>	12A
	Return value : 250	=>	2.5A

If the front-end module is target, an error is returned.

(Error code 6 : Command that do not correspond to the setting target)

If the instruction is executed on an output module other than the supported output modules, an error is returned.(Error code 6 : Command that do not correspond to the setting target)

6.10.7 READ_VIN_POINT [1Eh] [09h] [12h] [00h]

This command returns the number of the decimal places of "MON_VIN" command for the position of decimal point.

Return value	2
--------------	---

6.10.8 READ_VOUT_POINT [1Eh] [09h] [12h] [01h]

SELECT

This command returns the number of the decimal places of "MON_VOUT" command for the position of decimal point.

Return value	Except output module V : 3
	Output module V : 2

6.10.9 READ_IOUT_POINT [1Eh] [09h] [12h] [02h]

This command returns the number of the decimal places of "MON_IOUT" command for the position of decimal point.

Return value	2
--------------	---



Appendix 1. List of Extended-UART commands

Appendix 1 Lists of Extended UART commands (1/3)

Extended-UART commands	Command type	Code [Hexadecimal]	Remark
Commands to turn output voltage on/off			
CTL_REMOTE_ON	20bit	1Eh 08h 1Ch 00h	
CTL_REMOTE_OFF	20bit	1Eh 08h 1Ch 01h	
CTL_CH_REMOTE_ON	10bit	1Ah 1Eh [Argument]	
CTL_CH_REMOTE_OFF	10bit	1Ah 1Fh [Argument]	
CTL_REMOTE_ON_CH	20bit	1Eh 08h 1Ch 03h	
CTL_REMOTE_OFF_CH	20bit	1Eh 08h 1Ch 04h	
READ_REMOTE_CH_PRM	20bit	1Eh 09h 1Eh 09h	
READ_REMOTE_PRM	20bit	1Eh 09h 1Eh 08h	
READREMOTECONTROL	20bit	1Eh 09h 1Eh 01h	
READ_REMOTE_START_UP_PRM	20bit	1Eh 09h 1Eh 0Ah	
CTLPOWEROFFGI	20bit	1Eh 08h 1Ch 06h	
CTLPOWERONGI	20bit	1Eh 08h 1Ch 07h	
READCTL_GI	20bit	1Eh 09h 1Eh 05h	
SET_GI_TERMINAL_MODE_GI	20bit	1Eh 09h 0Eh 02h	
SET_GI_TERMINAL_MODE_RC	20bit	1Eh 09h 0Eh 03h	
READ_GI_TERMINAL_MODE_PRM	20bit	1Eh 09h 1Eh 06h	
CTL_RESET_LATCH	20bit	1Eh 08h 1Eh 1Fh	
Commands to set output voltage			
SET_VOUT	5bit	0Ah [Argument]	
READ_VOUT_PRM	20bit	1Eh 09h 1Bh 10h	
SET_VOUT_FACTORY_SETTING	20bit	1Eh 09h 0Bh 1Fh	
READ_VOUT_REFERENCE	20bit	1Eh 09h 1Bh 00h	
SET_VOUT_UPPER_LIMIT	10bit	17h 04h [Argument]	
READ_VOUT_UPPER_LIMIT_PRM	20bit	1Eh 09h 1Bh 14h	
SET_VOUT_LOWER_LIMIT	10bit	17h 05h [Argument]	
READ_VOUT_LOWER_LIMIT_PRM	20bit	1Eh 09h 1Bh 15h	
SET_VOUT_LIMIT_FACTORY_SETTING	20bit	1Eh 09h 0Bh 1Eh	
Commands to set constant current			
SET_CC_MODE_ITRM	20bit	1Eh 09h 0Ah 00h	
SET_CC_MODE_INFO	20bit	1Eh 09h 0Ah 01h	
READ_CC_MODE_PRM	20bit	1Eh 09h 1Ah 18h	
SET_CC	5bit	0Ch [Argument]	
READ_CC_PRM	20bit	1Eh 09h 1Ah 10h	
SET_CC_FACTORY_SETTING	20bit	1Eh 09h 0Ah 1Fh	
READ_CC_REFERENCE	20bit	1Eh 09h 1Ah 00h	
SET_CC_UPPER_LIMIT	10bit	18h 04h [Argument]	
READ_CC_UPPER_LIMIT_PRM	20bit	1Eh 09h 1Ah 14h	
SET_CC_LIMIT_FACTORY_SETTING	20bit	1Eh 09h 0Ah 1Eh	
SET_CC_CONTROL	10bit	18h 09h [Argument]	
READ_CC_CONTROL_PRM	20bit	1Eh 09h 1Ah 0Ch	

Appendix 1 Lists of Extended UART commands (2/3)

Extended-UART commands	Command type	Code [Hexadecimal]	Remark
Commands to set output voltage sequence			
SET_TON_DELAY_SLOT	5bit	0Fh [Argument]	
READ_TON_DELAY_SLOT_PRM	20bit	1Eh 09h 1Dh 06h	
SET_TON_DELAY_FACTORY_SETTING	20bit	1Eh 09h 0Dh 00h	
SET_TOFF_DELAY_SLOT	5bit	10h [Argument]	
READ_TOFF_DELAY_SLOT_PRM	20bit	1Eh 09h 1Dh 07h	
SET_TOFF_DELAY_FACTORY_SETTING	20bit	1Eh 09h 0Dh 01h	
SET_TON_DELAY_VIN	5bit	0Eh [Argument]	
READ_TON_DELAY_VIN_PRM	20bit	1Eh 09h 1Dh 00h	
SET_START_UP_VIN_AC	10bit	17h 00h [Argument]	
READ_START_UP_VIN_AC_PRM	20bit	1Eh 09h 1Ch 00h	
SET_STOP_VIN_AC	10bit	17h 01h [Argument]	
READ_STOP_VIN_AC_PRM	20bit	1Eh 09h 1Ch 01h	
SET_RAMP_RATE	10bit	1Ah 03h [Argument]	
READ_RAMP_RATE_PRM	20bit	1Eh 09h 1Dh 03h	
Commands to set accessory functions			
SET_FAN_MODE_AUTO	20bit	1Eh 09h 07h 00h	
SET_FAN_MODE_FIXED_SPEED	20bit	1Eh 09h 07h 01h	
READ_FAN_MODE_PRM	20bit	1Eh 09h 17h 00h	
SET_AUX_VOUT	10bit	17h 10h [Argument]	
READ_AUX_VOUT_PRM	20bit	1Eh 09h 18h 00h	
SET_VIN_LV_ALARM	10bit	16h 18h [Argument]	
READ_VIN_LV_ALARM_PRM	20bit	1Eh 09h 1Eh 03h	
SET_PR_TERMINAL_MODE_PR	20bit	1Eh 09h 0Eh 08h	
SET_PR_TERMINAL_MODE_PG	20bit	1Eh 09h 0Eh 09h	
READ_PR_TERMINAL_MODE_PRM	20bit	1Eh 09h 1Eh 0Dh	
SET_ALARM_STATUS	10bit	16h 19h [Argument]	
READ_ALARM_STATUS_PRM	20bit	1Eh 09h 1Eh 04h	
SET_VOUT_LV_ALARM	10bit	16h 1Bh [Argument]	
READ_VOUT_LV_ALARM_PRM	20bit	1Eh 09h 1Bh 1Eh	
SET_VOUT_HV_ALARM	10bit	16h 1Ch [Argument]	
READ_VOUT_HV_ALARM_PRM	20bit	1Eh 09h 1Bh 1Fh	
SET_VOUT_ALARM_FACTORY_SETTING	20bit	1Eh 09h 0Bh 1Dh	
Monitor commands			
MON_VIN	20bit	1Eh 08h 00h 01h	
MON_VIN_FREQUENCY	20bit	1Eh 08h 00h 1Fh	
MON_VOUT	20bit	1Eh 08h 01h 00h	
MON_IOUT	20bit	1Eh 08h 05h 00h	
MON_OUTPUT_POWER	20bit	1Eh 08h 08h 10h	
MON_FAN_SPEED_1	20bit	1Eh 08h 0Ch 00h	
MON_FAN_SPEED_2	20bit	1Eh 08h 0Ch 01h	
MON_AUX_VOUT	20bit	1Eh 09h 18h 01h	
MON_TEMPERATURE_1	20bit	1Eh 08h 0Eh 00h	

Appendix 1 Lists of Extended UART commands (3/3)

Extended-UART commands	Command type	Code [Hexadecimal]	Remark
State acquisition commands			
READ_STOP_CODE	20bit	1Eh 09h 1Eh 10h	
READ_PR_ALARM	20bit	1Eh 08h 14h 01h	
READ_PG_ALARM	20bit	1Eh 08h 14h 02h	
READ_LV_ALARM	20bit	1Eh 08h 14h 00h	
TOTAL_INPUT_TIME_1	20bit	1Eh 08h 10h 00h	
TOTAL_INPUT_TIME_2	20bit	1Eh 08h 10h 01h	
TOTAL_INPUT_TIME_3	20bit	1Eh 08h 10h 02h	
TOTAL_OUTPUT_TIME_1	20bit	1Eh 08h 11h 00h	
TOTAL_OUTPUT_TIME_2	20bit	1Eh 08h 11h 01h	
TOTAL_OUTPUT_TIME_3	20bit	1Eh 08h 11h 02h	
Commands to set address, memory, and communication			
SET_SELECTION_CH	10bit	1Ah 1Ch [Argument]	
READ_SELECTION_CH	20bit	1Eh 09h 1Fh 00h	
SET_WRITE_PROTECT_ON	20bit	1Eh 09h 05h 01h	
SET_WRITE_PROTECT_OFF	20bit	1Eh 09h 05h 02h	
READ_WRITE_PROTECT_PRM	20bit	1Eh 09h 15h 00h	
SYS_STORE_USER_SETTING	20bit	1Eh 09h 00h 10h	
SYS_RESTORE_FACTORY_SETTING	20bit	1Eh 09h 01h 1Fh	
READ_STORE_USER_SETTING	20bit	1Eh 09h 1Eh 00h	
CTL_ACCUMULATE_MODE_ON	20bit	1Eh 08h 1Ch 10h	
CTL_ACCUMULATE_MODE_OFF	20bit	1Eh 08h 1Ch 11h	
READ_ACCUMULATE_MODE	20bit	1Eh 08h 1Ch 12h	
CTL_ACCUMULATE_EXEC	20bit	1Eh 08h 1Ch 13h	
CTL_ACCUMULATE_CLEAR	20bit	1Eh 08h 1Ch 14h	
SET_ADDRESS	10bit	1Ah 10h [Argument]	
READ_ADDRESS_PRM	20bit	1Eh 09h 19h 10h	
READ_ADDRESS	20bit	1Eh 09h 19h 00h	
Commands to acquire product information			
READ_SERIAL	20bit	1Eh 09h 10h 00h	
READ_LOT_H	20bit	1Eh 09h 10h 01h	
READ_LOT_L	20bit	1Eh 09h 10h 02h	
READ_PRODUCT_INFO	20bit	1Eh 00h 07h 10h	
READ_RATED_VOUT	20bit	1Eh 09h 11h 00h	
READ_RATED_IOUT	20bit	1Eh 09h 11h 01h	
READ_VIN_POINT	20bit	1Eh 09h 12h 00h	
READ_VOUT_POINT	20bit	1Eh 09h 12h 01h	
READ_IOUT_POINT	20bit	1Eh 09h 12h 02h	

Appendix2. Availability and accuracy of Extended-UART commands

Appendix2 Availability and accuracy of Extended-UART commands (1/4)

Extended-UART commands	Availability/Accuracy(Ta=25°C Vo:*1)				Note
	Input module	Output module			
		A-D,J-M	E-H,S-V 2B-2M *2	P-R	
Commands to turn output voltage on/off					
CTL_REMOTE_ON	○	-	-	-	
CTL_REMOTE_OFF	○	-	-	-	
CTL_CH_REMOTE_ON	○	-	-	-	
CTL_CH_REMOTE_OFF	○	-	-	-	
CTL_REMOTE_ON_CH	-	○	○	○	
CTL_REMOTE_OFF_CH	-	○	○	○	
READ_REMOTE_CH_PRM	○	-	-	-	
READ_REMOTE_PRM	-	○	○	○	
READ_REMOTE_CONTROL	-	○	○	-	
READ_REMOTE_START_UP_PRM	○	-	-	-	
CTL_POWER_OFF_GI	○	-	-	-	
CTL_POWER_ON_GI	○	-	-	-	
READ_CTL_GI	○	-	-	-	
SET_GI_TERMINAL_MODE_GI	○	-	-	-	
SET_GI_TERMINAL_MODE_RC	○	-	-	-	
READ_GI_TERMINAL_MODE_PRM	○	-	-	-	
CTL_RESET_LATCH	○	-	-	-	
Commands to set output voltage					
SET_VOUT	-	±1%FS	±0.5%FS	-	
READ_VOUT_PRM	-	○	○	-	
SET_VOUT_FACTORY_SETTING	-	○	○	-	
READ_VOUT_REFERENCE	-	○	○	-	
SET_VOUT_UPPER_LIMIT	-	○	○	-	
READ_VOUT_UPPER_LIMIT_PRM	-	○	○	-	
SET_VOUT_LOWER_LIMIT	-	○	○	-	
READ_VOUT_LOWER_LIMIT_PRM	-	○	○	-	
SET_VOUT_LIMIT_FACTORY_SETTING	-	○	○	-	

*1 Output module A-D,J-M : 80% - 100%
 Output module E-H,S-U,2B-2M : 60% - 100%
 Output module V : 76.8% - 100%

*2 Include E4-H4, V4, and V5

Appendix2 Availability and accuracy of Extended-UART commands (2/4)

Extended-UART commands	Availability/Accuracy(Ta=25°C Vo:*1)				Note
	Input module	Output module			
		A-D,J-M	E-H,S-V 2B-2M *2	P-R	
Commands to set constant current					
SET_CC_MODE_ITRM	-	-	○	-	
SET_CC_MODE_INFO	-	-	○	-	
READ_CC_MODE_PRM	-	-	○	-	
SET_CC	-	-	±2%FS	-	
READ_CC_PRM	-	-	○	-	
SET_CC_FACTORY_SETTING	-	-	○	-	
READ_CC_REFERENCE	-	-	○	-	
SET_CC_UPPER_LIMIT	-	-	○	-	
READ_CC_UPPER_LIMIT_PRM	-	-	○	-	
SET_CC_LIMIT_FACTORY_SETTING	-	-	○	-	
SET_CC_CONTROL	-	-	○	-	
READ_CC_CONTROL_PRM	-	-	○	-	
Commands to set output voltage sequence					
SET_TON_DELAY_SLOT	-	±2%*3	±2%*3	±2%*3	*3 ±2%or±50msec
READ_TON_DELAY_SLOT_PRM	-	○	○	○	
SET_TON_DELAY_FACTORY_SETTING	-	○	○	○	
SET_TOFF_DELAY_SLOT	-	±2%*3	±2%*3	±2%*3	*3 ±2%or±50msec
READ_TOFF_DELAY_SLOT_PRM	-	○	○	○	
SET_TOFF_DELAY_FACTORY_SETTING	-	○	○	○	
SET_TON_DELAY_VIN	±2%*3	-	-	-	*3 ±2%or±50msec
READ_TON_DELAY_VIN_PRM	○	-	-	-	
SET_START_UP_VIN_AC	±3%FS	-	-	-	
READ_START_UP_VIN_AC_PRM	○	-	-	-	
SET_STOP_VIN_AC	±3%FS	-	-	-	
READ_STOP_VIN_AC_PRM	○	-	-	-	
SET_RAMP_RATE	-	-	○	-	
READ_RAMP_RATE_PRM	-	-	○	-	

*1 Output module A-D,J-M : 80% - 100%
 Output module E-H,S-U,2B-2M : 60% - 100%
 Output module V : 76.8% - 100%

*2 Include E4-H4, V4, and V5

Appendix2 Availability and accuracy of Extended-UART commands (3/4)

Extended-UART commands	Availability/Accuracy(Ta=25°C Vo:*1)				Note
	Input module	Output module			
		A-D,J-M	E-H,S-V 2B-2M *2	P-R	
Commands to set accessory functions					
SET_FAN_MODE_AUTO	○	-	-	-	
SET_FAN_MODE_FIXED_SPEED	○	-	-	-	
READ_FAN_MODE_PRM	○	-	-	-	
SET_AUX_VOUT	±5%FS	-	-	-	
READ_AUX_VOUT_PRM	○	-	-	-	
SET_VIN_LV_ALARM	○	-	-	-	
READ_VIN_LV_ALARM_PRM	○	-	-	-	
SET_PR_TERMINAL_MODE_PR	○	-	-	-	
SET_PR_TERMINAL_MODE_PG	○	-	-	-	
READ_PR_TERMINAL_MODE_PRM	○	-	-	-	
SET_ALARM_STATUS	○	-	-	-	
READ_ALARM_STATUS_PRM	○	-	-	-	
SET_VOUT_LV_ALARM	-	○	○	-	
READ_VOUT_LV_ALARM_PRM	-	○	○	-	
SET_VOUT_HV_ALARM	-	○	○	-	
READ_VOUT_HV_ALARM_PRM	-	○	○	-	
SET_VOUT_ALARM_FACTORY_SETTING	-	○	○	-	
Monitor commands					
MON_VIN	±3%FS	-	-	-	
MON_VIN_FREQUENCY	±1Hz	-	-	-	
MON_VOUT	-	±1%FS	±1%FS	-	
MON_IOUT	-	-	±2%FS	-	
MON_OUTPUT_POWER	-	-	±2%FS	-	
MON_FAN_SPEED_1	±500rpm	-	-	-	
MON_FAN_SPEED_2	±500rpm*3	-	-	-	
MON_AUX_VOUT	±5%FS	-	-	-	
MON_TEMPERATURE_1	±5deg*4	-	-	-	

*1 Output module A-D,J-M : 80% - 100%
 Output module E-H,S-U,2B-2M : 60% - 100%
 Output module V : 76.8% - 100%

*2 Include E4-H4, V4, and V5

*3 This command is only for AME800F and AME1200F

*4 The value at -20 to 100°C. Indicates the accuracy to the actual temperature of the measurement point.
 Not Ambient temperature. The value also affected by fan speed.

Appendix2 Availability and accuracy of Extended-UART commands (4/4)

Extended-UART commands	Availability/Accuracy(Ta=25°C Vo:*1)				Note
	Input module	Output module			
		A-D,J-M	E-H,S-V 2B-2M *2	P-R	
State acquisition commands					
READ_STOP_CODE	○	○	○	-	
READ_PR_ALARM	○	-	-	-	
READ_PG_ALARM	○	-	-	-	
READ_LV_ALARM	-	○	○	-	
TOTAL_INPUT_TIME_1	○	-	-	-	
TOTAL_INPUT_TIME_2	○	-	-	-	
TOTAL_INPUT_TIME_3	○	-	-	-	
TOTAL_OUTPUT_TIME_1	○	○	○	-	
TOTAL_OUTPUT_TIME_2	○	○	○	-	
TOTAL_OUTPUT_TIME_3	○	○	○	-	
Commands to set address, memory, and communication					
SET_SELECTION_CH	○	○	○	○	
READ_SELECTION_CH	○	○	○	○	
SET_WRITE_PROTECT_ON	○	-	-	-	
SET_WRITE_PROTECT_OFF	○	-	-	-	
READ_WRITE_PROTECT_PRM	○	-	-	-	
SYS_STORE_USER_SETTING	○	○	○	-	
SYS_RESTORE_FACTORY_SETTING	○	○	○	-	
READ_STORE_USER_SETTING	○	○	○	-	
CTL_ACCUMULATE_MODE_ON	○	-	-	-	
CTL_ACCUMULATE_MODE_OFF	○	-	-	-	
READ_ACCUMULATE_MODE	○	-	-	-	
CTL_ACCUMULATE_EXEC	○	-	-	-	
CTL_ACCUMULATE_CLEAR	○	-	-	-	
SET_ADDRESS	○	-	-	-	
READ_ADDRESS_PRM	○	-	-	-	
READ_ADDRESS	○	-	-	-	
Commands to acquire product information					
READ_SERIAL	○	-	-	-	
READ_LOT_H	○	-	-	-	
READ_LOT_L	○	-	-	-	
READ_PRODUCT_INFO	○	○	○	○	
READ_RATED_VOUT	-	○	○	-	
READ_RATED_IOUT	-	○	○	-	
READ_VIN_POINT	○	-	-	-	
READ_VOUT_POINT	-	○	○	-	
READ_IOUT_POINT	○	-	-	-	

*1 Output module A-D,J-M : 80% - 100%
 Output module E-H,S-U,2B-2M : 60% - 100%
 Output module V : 76.8% - 100%

*2 Include E4-H4, V4, and V5

Appendix3. Control block overview

This product has a built-in microcontrollers and has a built-in RAM (volatile memory) and ROM (non-volatile memory). Parameters stored in the memory are used for the control of the power supply and Extended-UART.

Appendix3 is a block diagram.

The front-end module has two microcontrollers and (primary and secondary) and each output module have one microcontroller (※).

The primary microcontroller on the front-end is used for Extended-UART.

The target microcontroller is selected and communicated to change the parameters in each microcontrollers.

※ The presence or absence of microcontrollers and usability of commands differ depending on the output module.

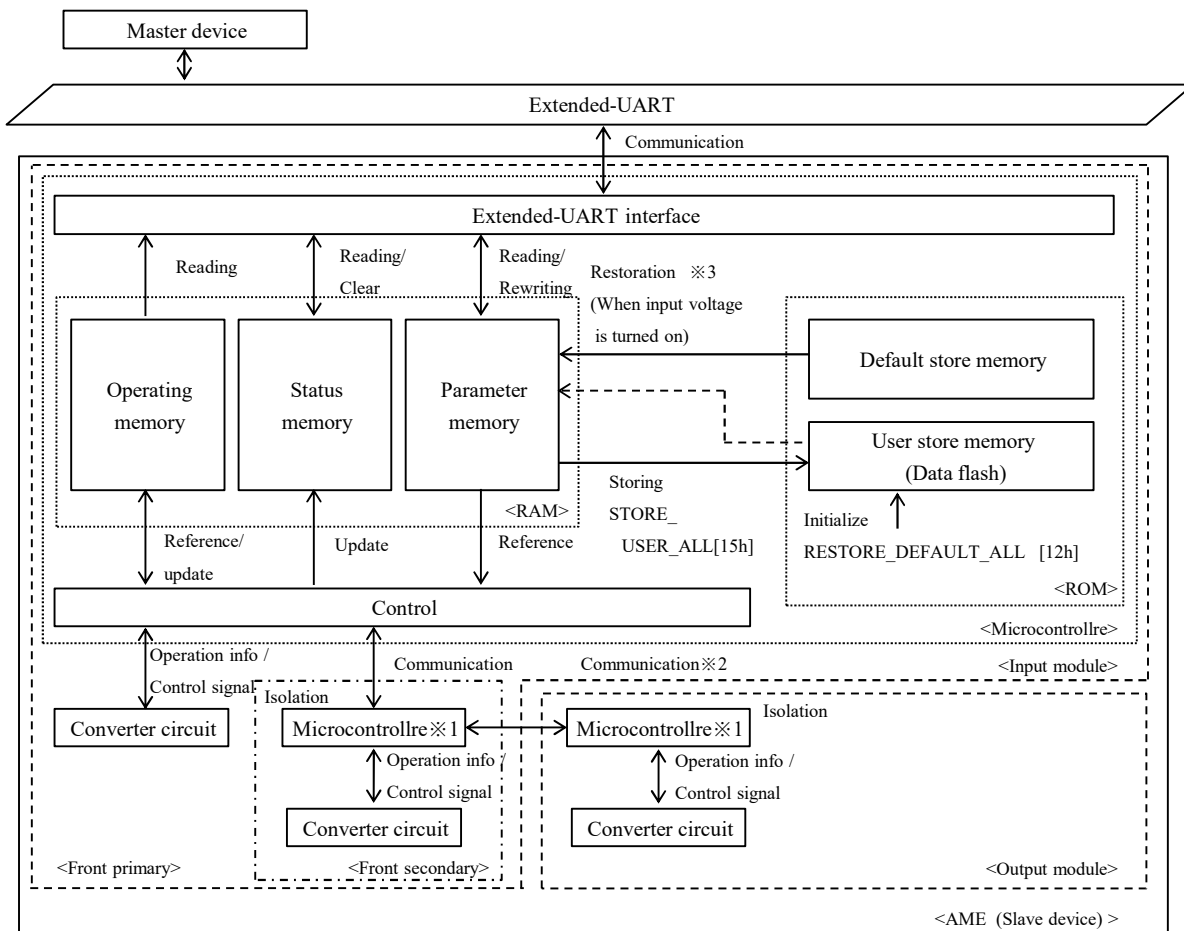

Appendix3 Block diagram for PMBus

- ※1 Omit Internal block
- ※2 Use the PAGE command to select the target microcomputer and perform communication.
- ※3 Parameter memory is restored from default store memory or user store memory.

Table 4.1

No.	Status of user store memory	Memory source for restoration of Parameter memory	Remark
1	There is no data (factory shipping status, etc.)	Default store memory	
2	There is data	User store memory	



index

Command	Item No.	Page	Command	Item No.	Page
CTL_ACCUMULATE_CLEAR	6.9.13	47	READ_PRODUCT_INFO	6.10.4	48
CTL_ACCUMULATE_EXEC	6.9.12	46	READ_RAMP_RATE_PRM	6.5.14	30
CTL_ACCUMULATE_MODE_OFF	6.9.10	46	READ_RATED_IOUT	6.10.6	49
CTL_ACCUMULATE_MODE_ON	6.9.9	46	READ_RATED_VOUT	6.10.5	49
CTL_CH_REMOTE_OFF	6.2.4	16	READ_REMOTE_CH_PRM	6.2.7	17
CTL_CH_REMOTE_ON	6.2.3	15	READ_REMOTE_CONTROL	6.2.9	17
CTL_POWER_OFF_GI	6.2.11	18	READ_REMOTE_PRM	6.2.8	17
CTL_POWER_ON_GI	6.2.12	18	READ_REMOTE_START_UP_PRM	6.2.10	18
CTL_REMOTE_OFF	6.2.2	15	READ_SELECTION_CH	6.9.2	42
CTL_REMOTE_OFF_CH	6.2.6	16	READ_SERIAL	6.10.1	48
CTL_REMOTE_ON	6.2.1	15	READ_START_UP_VIN_AC_PRM	6.5.10	29
CTL_REMOTE_ON_CH	6.2.5	16	READ_STOP_CODE	6.8.1	38
CTL_RESET_LATCH	6.2.17	19	READ_STOP_VIN_AC_PRM	6.5.12	29
MON_AUX_VOUT	6.7.8	37	READ_STORE_USER_SETTING	6.9.8	45
MON_FAN_SPEED_1	6.7.6	37	READ_TOFF_DELAY_SLOT_PRM	6.5.5	27
MON_FAN_SPEED_2	6.7.7	37	READ_TON_DELAY_SLOT_PRM	6.5.2	26
MON_IOUT	6.7.4	36	READ_TON_DELAY_VIN_PRM	6.5.8	28
MON_OUTPUT_POWER	6.7.5	36	READ_VIN_LV_ALARM_PRM	6.6.7	33
MON_TEMPERATURE_1	6.7.9	37	READ_VIN_POINT	6.10.7	49
MON_VIN	6.7.1	36	READ_VOUT_HV_ALARM_PRM	6.6.16	35
MON_VIN_FREQUENCY	6.7.2	36	READ_VOUT_LOWER_LIMIT_PRM	6.3.8	22
MON_VOUT	6.7.3	36	READ_VOUT_LV_ALARM_PRM	6.6.14	34
READ_ACCUMULATE_MODE	6.9.11	46	READ_VOUT_POINT	6.10.8	49
READ_ADDRESS	6.9.16	47	READ_VOUT_PRM	6.3.2	20
READ_ADDRESS_PRM	6.9.15	47	READ_VOUT_REFERENCE	6.3.4	21
READ_ALARM_STATUS_PRM	6.6.12	34	READ_VOUT_UPPER_LIMIT_PRM	6.3.6	22
READ_AUX_VOUT_PRM	6.6.5	32	READ_WRITE_PROTECT_PRM	6.9.5	43
READ_CC_CONTROL_PRM	6.4.12	25	SET_ADDRESS	6.9.14	47
READ_CC_MODE_PRM	6.4.3	23	SET_ALARM_STATUS	6.6.11	33
READ_CC_PRM	6.4.5	23	SET_AUX_VOUT	6.6.4	32
READ_CC_REFERENCE	6.4.7	24	SET_CC	6.4.4	23
READ_CC_UPPER_LIMIT_PRM	6.4.9	24	SET_CC_CONTROL	6.4.11	25
READ_CTL_GI	6.2.13	18	SET_CC_FACTORY_SETTING	6.4.6	24
READ_FAN_MODE_PRM	6.6.3	32	SET_CC_LIMIT_FACTORY_SETTING	6.4.10	24
READ_GI_TERMINAL_MODE_PRM	6.2.16	19	SET_CC_MODE_INFO	6.4.2	23
READ_IOUT_POINT	6.10.9	49	SET_CC_MODE_ITRM	6.4.1	23
READ_LOT_H	6.10.2	48	SET_CC_UPPER_LIMIT	6.4.8	24
READ_LOT_L	6.10.3	48	SET_FAN_MODE_AUTO	6.6.1	32
READ_LV_ALARM	6.8.4	39	SET_FAN_MODE_FIXED_SPEED	6.6.2	32
READ_PG_ALARM	6.8.3	39	SET_GI_TERMINAL_MODE_GI	6.2.14	19
READ_PR_ALARM	6.8.2	38	SET_GI_TERMINAL_MODE_RC	6.2.15	19
READ_PR_TERMINAL_MODE_PRM	6.6.10	33	SET_PR_TERMINAL_MODE_PG	6.6.9	33



For AME series

Command	Item No.	Page
SET_PR_TERMINAL_MODE_PR	6.6.8	33
SET_RAMP_RATE	6.5.13	30
SET_SELECTION_CH	6.9.1	41
SET_START_UP_VIN_AC	6.5.9	29
SET_STOP_VIN_AC	6.5.11	29
SET_TOFF_DELAY_FACTORY_SETTING	6.5.6	27
SET_TOFF_DELAY_SLOT	6.5.4	27
SET_TON_DELAY_FACTORY_SETTING	6.5.3	26
SET_TON_DELAY_SLOT	6.5.1	26
SET_TON_DELAY_VIN	6.5.7	28
SET_VIN_LV_ALARM	6.6.6	33
SET_VOUT	6.3.1	20
SET_VOUT_ALARM_FACTORY_SETTING	6.6.17	35
SET_VOUT_FACTORY_SETTING	6.3.3	21
SET_VOUT_HV_ALARM	6.6.15	35
SET_VOUT_LIMIT_FACTORY_SETTING	6.3.9	22
SET_VOUT_LOWER_LIMIT	6.3.7	22
SET_VOUT_LV_ALARM	6.6.13	34
SET_VOUT_UPPER_LIMIT	6.3.5	22
SET_WRITE_PROTECT_OFF	6.9.4	42
SET_WRITE_PROTECT_ON	6.9.3	42
SYS_RESTORE_FACTORY_SETTING	6.9.7	44
SYS_STORE_USER_SETTING	6.9.6	43
TOTAL_INPUT_TIME_1	6.8.5	39
TOTAL_INPUT_TIME_2	6.8.5	39
TOTAL_INPUT_TIME_3	6.8.5	39
TOTAL_OUTPUT_TIME_1	6.8.6	40
TOTAL_OUTPUT_TIME_2	6.8.6	40
TOTAL_OUTPUT_TIME_3	6.8.6	40

A. Revision history

No.	Date	Ver	Page	Note
1	2019.11.11	1.0E	-	First edition issued
2	2020.2.12	1.1E	43,44	Additional content added to "SYS_STORE_USER_SETTING"
3			44	Additional content added to "SYS_RESTORE_FACTORY_SETTING"
4			app-7	Appendix2 has been modified
5			app-8	Appendix3 has been added
6			I-1	Add page number to index
7	2020.11.13	1.2E	4	3.2 has been added
8			38	Added stop code of Output module to "READ_STOP_CODE"
9			44	Additional content added to "SYS_STORE_USER_SETTING"
10			app-6	※4 has been modified
11			app-8	Appendix1 has been modified
12			-	Corresponds to module J-M, E4-H4, R
13	2021.9.10	1.3E	5	Processing time: Maximum 150msec modified to maximum 200msec
14			28	Changed the lower limit of the setting range for "SET_TON_DELAY_VIN" from 800 to 790
15			49	Changed "READ_VOUT_POINT" to be a target of "SET_SELECTION_CH"
16			-	Corresponds to module S-V, V4, V5
17	2021.12.20	1.4E	15,16	※1,2 been added
18			36	"MON_VOUT" has been modified
19			41,42	Added command table item number
20			app-7	Appendix2 has been modified
21	2026.4.2	1.5E	34	Add the maximum limit of the "SET_VOUT_LV_ALARM" setting range
22			48,49	Add modules 2B-2M, P, and Q to "READ_PRODUCT_INFC"
23			-	Corresponds to module 2B-2M,P,Q
24				
25				
26				
27				
28				
29				
30				