



COSEL

AME Series(-I option)
PMBus Communication Manual



AME series ---PMBus---

		Page
1. Overview		1
2. Extended-UART Wiring and Connection		1
2.1	PMBus pins of AME series	1
2.2	Connection method	2
2.3	PMBus communication cable pattern example	2
2.4	PMBus communication pull-up resistor value	3
2.5	Address setting	3
3. Data format		4
3.1	Data format for output voltage	4
3.2	Other (except output voltage) data format	4
4. Functions of PMBus		5
4.1	Control block	5
4.2	Clock stretching	6
4.3	SMBALERT	6
4.4	Packet error checking(PEC)	6
5. PMBus hardware specifications		7
5.1	Absolute maximum ratings for communication terminals	7
5.2	Electrical characteristics of communication terminals	7
5.3	Note	7
6. Command specification of PMBus		8
6.1	Outline of each command	8
6.2	Commands to turn output voltage on/off	11
6.3	Commands to set output voltage	15
6.4	Commands to set constant current	17
6.5	Commands to set output voltage sequence	19
6.6	Commands to set accessory functions	24
6.7	Monitor commands	25
6.8	State acquisition commands	27
6.9	Commands to set address, memory, and communication	32
6.10	Commands to acquire product information	39
Appendix		
Appendix	Availability and accuracy of PMBus commands index	Appendix-1 I-1
A. Revision history		A-1

Note: The contents described in this document are those available at the time of publication and are subject to change without prior notice due to product improvement and corresponding changes in the specifications. Please check the web page of COSEL for the latest version.

We have paid full attention to ensure the accuracy of this document. We will not be responsible for any damages, including those due to misstatement and/or missing information, and indirect faults resulting from the use of the information in this document.

1. Overview

With this product, monitoring of the operational status of the power supply and changing of various set values are possible using the PMBus.

In addition, the non-volatilization memory in AME can maintain various set values and information even if input voltage is shut off.

For detail, refer to PMBus standard spec manual : PMBus Power System Management Protocol Specification

Part I (Revision1.2) and Part II (Revision1.2).

2. PMBus Wiring and Connection

2.1 PMBus pin function of AME series

Tables 2.1 show the pin names and functions of this product, related to the PMBus.

Table 2.1 CN2 PMBus related pin function

Pin number	Pin name	Function
1	SDA	Serial data
2	SGND	Signal ground
3	SCL	Serial clock
4	SMBA	SMBAAlert
5	ADDR0	Address bit 0
6	ADDR1	Address bit 1
7	ADDR2	Address bit 2
8	SGND	Signal ground

Note : AUXG is not isolated from SGND.

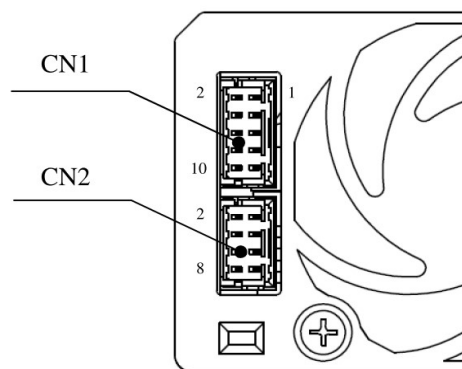

Figure 2.1 AME series connector

2.2 Connection method

Figure 2.2 shows an example of connection when using PMBus.

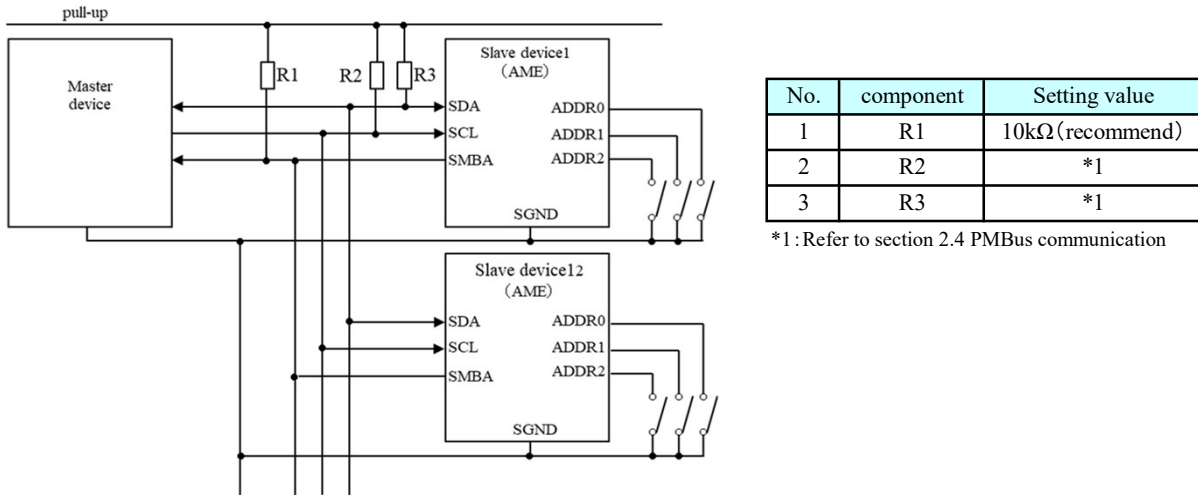

Figure 2.2 Example of PMBus connection

2.3 PMBus communication cable pattern example

When connecting the PMBus communication cable, please make sure to minimize noise from outside and crosstalk by positioning Signal ground between Serial data bus and Serial clock bus as shown Figure 2.3.

Also, make sure of the right setting for the pull-up resistor as parasitic capacitance can happen by way of shielding and length of cabling. (refer to clause 2.4)

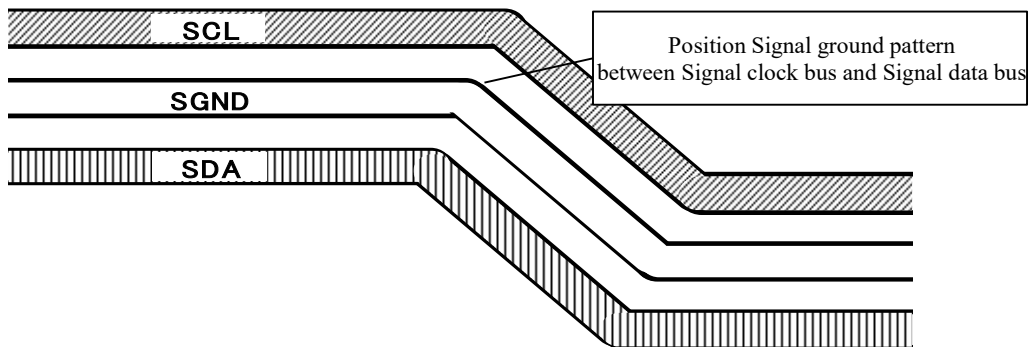

Figure 2.3 Pattern example

2.4 PMBus communication pull-up resistor value

It is necessary to connect pull-up resistor on Signal data bus and Signal clock bus terminal of PMBus Recommended value of resistor(maximum value) is shown at figure 2.4.

Note: Do not exceed the rated output current of converter's terminal (Section 5.1).

Note: Total parasitic capacitance and input capacitance should be less 400pF. (Including AME terminal capacitance)

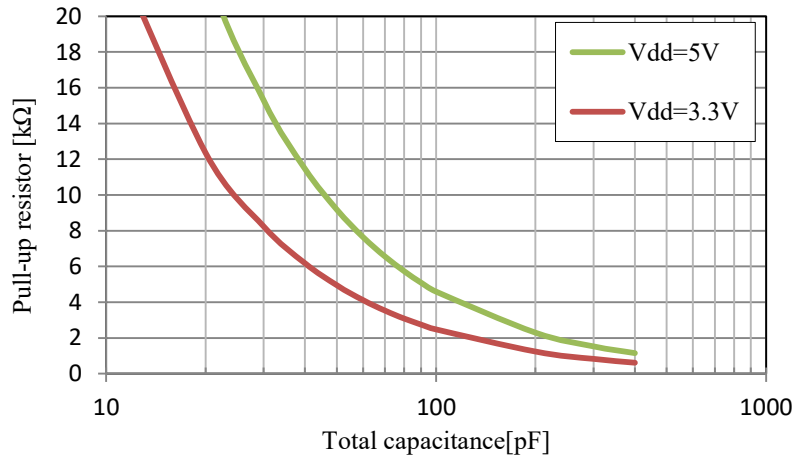

Figure 2.4 Recommended value of pull-up resistor

2.5 Address setting

The address can be set to be one of the seven types from "16" to "23" .

The address can be set by selecting the connection between the address setting pins (ADDR0, ADDR1, ADDR2) and the signal ground (SGND).

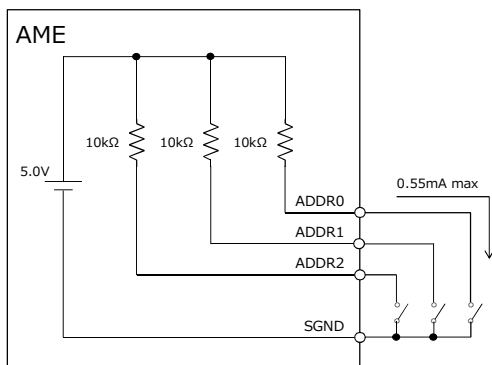

Table 2.2 Address setting

Fixed value (bit6 - 3)	ADDR2 (bit2)	ADDR1 (bit1)	ADDR0 (bit0)	PMBus Address
0010	0	0	0	16
	0	0	1	17
	0	1	0	18
	0	1	1	19
	1	0	0	20
	1	0	1	21
	1	1	0	22
	1	1	1	23

0: Short 1: Open

Figure 2.5 Method of address setting

3. Data format

3.1 Data format for output voltage

SUGGESTION Set and read the output voltage(Including AUX voltage) according to the Linear format shown below. Bits 7:5 of VOUT_MODE [20h] should read “000” for linear mode. N is a 5 bit two’s complement binary integer. The mantissa (Part Y) is a 16 bit unassigned binary integer. The voltage (in volts) is calculated by the equation $VALUE = Y \cdot 2^N$

VOUT_MODE [20h]

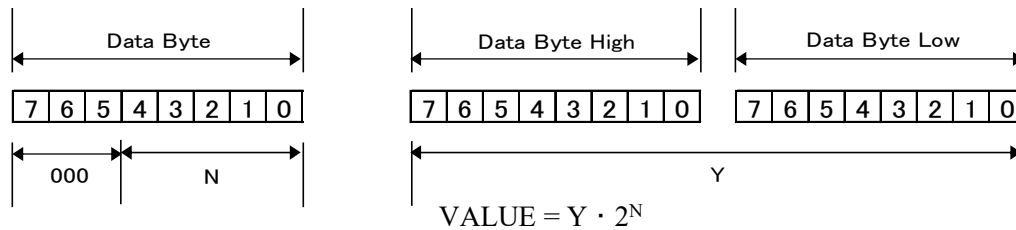

3.2 Other (except output voltage) data format

SUGGESTION: Set and read a command according to the Linear format shown below. N is a 5 bit two’s complement integer, which differs depending on the command. The mantissa (Part Y) is an 11 bit, two’s complement integer. The parameter is calculated by the equation $VALUE = Y \cdot 2^N$

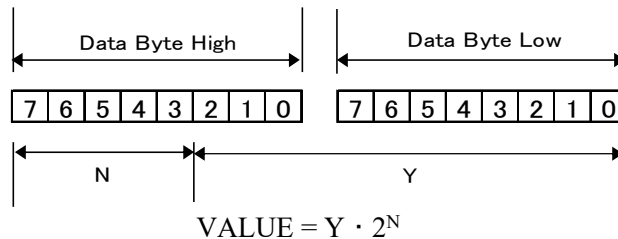

Table 3.1 Index part N value

No.	Item	Display format	Characteristics N				Unit
			3.3V - 7.5V	12V - 36V	48V	75V	
1	Output voltage	Linear(Vout)※	-10			-9	V
2	Output current	Linear(Iout)	-4	-5	-6		A
3	Output power	Linear(Pout)	-1				W
4	Input voltage	Linear(Vin)	-1				V
5	AUX output voltage	Linear(Vout)※	-10				V
6	Starting-up time (Vin)	Linear(Time_1)	6				msec
7	Starting-up time (RC)	Linear(Time_2)	5				msec
8	Temperature	Linear(Temp)	0				℃
9	Fan speed	Linear(Fan)	5				rpm
10	Input-voltage frequency	Linear(Vin_Freq)	0				Hz

Note: Data format for output voltage

4.2 Clock stretching

AME has a clock stretching function.

Use a master device that can support clock stretching.

The clock stretch time differs depending on the command and the target microcontroller.

4.3 SMBALERT

SMBALERT protocol is also supported by the module. The module can alert the PMBus master that it has an active status or alarm condition. (Refer to standard manual of SMBus for details : System Management Bus(SMBus) Specification Ver 2.0)

Note: When multiple slave devices issue SMBALERT signal at the same time, it is not possible to make judgment for slave address by ARA.

(Initial state: ARA is invalid)

If alarm condition continues, execute ARA operation again after executing CLEAR_FAULTS [03h]. If it is difficult to remove the abnormal operation, perform analysis of the abnormal operation without disabling ARA with MFR_ARA_CONFIG [E0h] during power off or without executing CLEAR_FAULTS [03h].

4.4 Packet error checking (PEC)

This product supports packet error checking (PEC).

We recommend using PEC when you implement PMBus communication.

(Refer to standard manual of SMBus for details : System Management Bus(SMBus) Specification Ver 2.0)

If an error occurs in the communication data, such as the output voltage set value is written abnormal value, possibly to damage the load device.

When not using the PEC, to check that the communication error does not occur.

5. PMBus hardware specification

5.1 Absolute maximum ratings for communication terminals

Table 5.1 shows the absolute maximum ratings of the PMBus terminals.

Table 5.1 Absolute maximum ratings

No.	Item	Min	Max	Unit	Remark
1	Input voltage	-0.3	5.5	V	
2	Maximum output current	-4	-	mA	

5.2 Electrical characteristics of communication terminals

Table 5.2 shows the electrical characteristics of the PMBus terminals.

Table 5.2 Electrical characteristics

No.	Item	Min	Max	Unit	Remark
1	Input pull-up voltage	2.7	5.5	V	
2	Input High level voltage	2.1	-	V	
3	Input Low level voltage	-	0.8	V	
4	Output Low level voltage	-	0.5	V	
5	Output High level open drain Leak current	-	0.2	mA	
6	PMBus communication frequency range	10	400	kHz	

5.3 Note

Wait for more than 300us after stop-condition. If the wait time is short, the slave cannot communicate.

6. Command specification of PMBus

6.1 Outline of each command

Table 6.1(1/3), 6.1(2/3) and 6.1(3/3) are outline of commands in Extended-UART.

The corresponding commands differ depending on the module. See Appendix for corresponding commands.

Some commands require selection of the setting target by "PAGE". See to 6.9.1 for the target command.

Table 6.1 Outline of each command (1/3)

6.2 Commands to turn output voltage on/off				
1	OPERATION	01h	Enabling or disabling the output in the selected slot.	R/W
2	MFR_OPERATION_STATE	EEh	Returns the output ON/OFF status.	R
3	MFR_OPERATION_SLOT	D8h	Returns the output in the arbitrary slot ON/OFF status.	R/W
4	MFR_GI	D7h	Activating or deactivating the GI(Global Inhibit).	R/W
5	MFR_CTL_RESET_LATCH	E1h	Clearing latch off.	S
6.3 Commands to set output voltage				
1	VOUT_MODE	20h	Returns an output voltage format form.	R
2	VOUT_COMMAND	21h	Setting the output voltage.	R/W
3	MFR_VOUT_FACTORY_SETTING	E3h	Restoring a factory setting for the output voltage.	S
4	MFR_VOUT_REFERENCE	EAh	Returning the controlling value for the output voltage.	R
5	VOUT_MAX	24h	Setting a upper limit for the output voltage adjustment range.	R/W
6	MFR_VOUT_MIN	D3h	Setting a lower limit for the output voltage adjustment range.	R/W
7	MFR_VOUT_LIMIT_FACTORY_SETTING	E5h	Restoring a factory default value of a upper and a lower limit for the output voltage adjustment range.	S
6.4 Commands to set constant current				
1	MFR_CC_MODE	D1h	Sets the setting method of constant current.	R/W
2	MFR_CC	D0h	Setting a value of the constant current.	R/W
3	MFR_CC_FACTORY_SETTING	E4h	Restoring a factory default value of the constant current.	S
4	MFR_CC_REFERENCE	EBh	Returning the controlling value for the constant current.	R
5	MFR_CC_MAX	D2h	Setting a upper limit for the constant current adjustment range.	R/W
6	MFR_CC_LIMIT_FACTORY_SETTING	E6h	Restoring a factory default value of a upper limit for the constant current.	S
7	MFR_CC_CONTROL	DFh	Setting a controlled variable of the constant current.	R/W
6.5 Commands to set output voltage sequence				
1	MFR_TON_DELAY_SLOT	D9h	Setting a power-on delay time.	R/W
2	MFR_TON_DELAY_SLOT_FACTORY_SETTING	E7h	Restoring a factory default value of the power-on delay time.	S
3	TOFF_DELAY	64h	Setting a power-off delay time.	R/W
4	MFR_TOFF_DELAY_FACTORY_SETTING	E8h	Restoring a factory default value of the power-off delay time.	S
5	MFR_TON_DELAY_VIN	DAh	Setting delay time for activation after AC input.	R/W
6	MFR_RAMP_RATE	DBh	Setting a ramp rate of the output voltage.	R/W
7	VIN_ON	35h	Setting a stopping voltage for AC input.	R/W
8	VIN_OFF	36h	Setting a stopping voltage for AC input.	R/W

R : Read command

W : Write command

S : Send command

Table 6.1 Outline of each command (2/3)

6.6 Commands to set accessory functions				
1	MFR_FAN_MODE	D6h	Set the fan control method, automatic or full speed	R/W
2	MFR_AUX_VOUT	DCh	Setting the output voltage for the AUX power.	R/W
3	VIN_UV_WARN_LIMIT	58h	Setting the input low voltage warning threshold	R/W
6.7 Monitor commands				
1	READ_VIN	88h	Returning a value of the input voltage.	R
2	MFR_READ_VIN_FREQUENCY	E9h	Returning a value of the input frequency.	R
3	READ_VOUT	8Bh	Returning a value of the output voltage.	R
4	READ_IOUT	8Ch	Returning a value of the output current.	R
5	READ_POUT	96h	Returning a value of the output power.	R
6	READ_FAN_SPEED_1	90h	Returning a value of the rotation-speed control for the built-in air-cooling fan 1.	R
7	READ_FAN_SPEED_2	91h	Returning a value of the rotation-speed control for the built-in air-cooling fan 2.	R
8	READ_TEMPERATURE_1	8Dh	Returning a value of the temperature for internal components.	R
6.8 State acquisition commands				
1	CLEAR_FAULTS	03h	Clear the "STATUS Register" after any fault occurs and reset the SMBALERT signal	S
2	SMBALERT_MASK	1Bh	Prevent a warning or fault condition from asserting the SMBALERT signal	R/W
3	STATUS_BYTE	78h	Returns the error state	R/W
4	STATUS_WORD	79h	Returns the error state	R/W
5	STATUS_INPUT	7Ch	Return the input state	R/W
6	STATUS_TEMPERATURE	7Dh	Returns the temperature error state	R/W
7	STATUS_CML	7Eh	Returns the communication error state	R/W
8	STATUS_MFR_SPECIFIC	80h	Returns specific error state (For what error?)	R/W
9	STATUS_FANS_1_2	81h	Returns the built-in fan error state	R/W
10	MFR_ARA_CONFIG	E0h	Sets the SMBALERT configure	R/W
11	MFR_STOP_CODE	FCh	Returns the code indicating the stop status	R
12	MFR_READ_TOTAL_INPUT_TIME_1	EFh	Returning an accumulated time that the input voltage has been applied. (minute)	R
	MFR_READ_TOTAL_INPUT_TIME_2	F0h	Returning an accumulated time that the input voltage has been applied. (low 16 bits of hour)	R
	MFR_READ_TOTAL_INPUT_TIME_3	F1h	Returning an accumulated time that the input voltage has been applied. (high 16 bits of hour)	R
13	MFR_READ_TOTAL_OUTPUT_TIME_1	F2h	Returning an accumulated operation time. (minute)	R
	MFR_READ_TOTAL_OUTPUT_TIME_2	F3h	Returning an accumulated operation time. (low 16 bits of hour)	R
	MFR_READ_TOTAL_OUTPUT_TIME_3	F4h	Returning an accumulated operation time. (high 16 bits of hour)	R

R : Read command

W : Write command

S : Send command

Table 6.1 Outline of each command (3/3)

6.9 Commands to set address, memory, and communication				
1	PAGE	00h	Setting a selected slot.	R/W
2	CAPABILITY	19h	Returns the support status of the communication	R
3	WRITE_PROTECT	10h	Control writing to the PMBus interface device	R/W
4	STORE_USER_ALL	15h	Storing settings into the internal non-volatile memory.	S
5	RESTORE_DEFAULT_ALL	12h	Restoring a factory default for settings.	S
6	MFR_ACCUMULATE_MODE	F6h	Enables or disables switching accumulation mode	R/W
7	MFR_ACCUMULATE_EXEC	F7h	Execution command in the accumulation mode.	S
8	MFR_READ_ACCUMULATE_DATA	F8h	Returns buffer in the accumulation mode	R
9	MFR_CLEAR_ACCUMULATE_DATA	F9h	Erasing buffer in the accumulation mode.	S
10	MFR_ADDRESS	D4h	Setting a communication address.	R/W
11	MFR_READ_ADDRESS	EDh	Returning a communication address.	R
6.10 Commands to acquire product information				
1	PMBUS_REVISION	98h	Returns the revision of the PMBus implemented	R
2	MFR_SERIAL	9Eh	Returns the product serial number (ASCII)	R
3	MFR_MODEL	9Ah	Returns the product name (ASCII)	R
4	MFR_LOCATION	9Ch	Returns manufacturing location of the product	R
5	MFR_RATED_VOUT	FAh	Returning the rated voltage of the model.	R
6	MFR_RATED_IOUT	FBh	Returning the rated current of the model.	R

R : Read command

W : Write command

S : Send command

The function and the setting method for each command are shown below.

Notation

6.x.x **VOUT_COMMAND**

[21h]

R/W Word

PAGE

Command name

Command code

Communication format

Representing a command that needs to select(*) the target. (Refer to 6.9.1 for the detail.)

*It is necessary to select the microcontroller of communication target , because the power supply has multiple microcontrollers.(Refer to Appendix 4.1.)

6.2 Commands to turn output voltage on/off

6.2.1 OPERATION [01h] R/W Byte

PAGE

This is a command to enable the output voltage. (Remote on/off function.)

With this command, the output voltage can be turned ON or OFF.

When OFF is specified by the RC2 terminal, the output voltage will not turn ON.

bit	7	6	5	4	3	2	1	0	Remark
Initial setting	1	0	0	0	0	0	0	0	80h
Access	R/W	R/W	R	R	R	R	R	R	

No.	setting				Output	Explanation
	bit7-6	bit5-4	bit3-2	bit1-0		
1	00	XX	XX	XX	OFF	Power supply stops (No DC Output)
2	01	XX	XX	XX	OFF	Stop by sequence TOFF_DELAY [64h], TOFF_FALL [65h] (not supported)
3	10	00	XX	XX	ON	Set output voltage to value of VOUT_COMMAND [21h]
4	10	01	01	XX	ON	Set output voltage value of VOUT_MARGIN_LOW [26h] (not supported)
5	10	01	10	XX	ON	Set output voltage value of VOUT_MARGIN_LOW [26h] (not supported)
6	10	10	01	XX	ON	Set output voltage value of VOUT_MARGIN_HIGH [25h] (not supported)
7	10	10	10	XX	ON	Set output voltage value of VOUT_MARGIN_HIGH [25h] (not supported)

XX : Ignore

When the output is turned off in item No. 1 or 2, the output voltage is turned off regardless of the setting of MFR_OPERATION_SLOT [D8h].

If the input module is set as target module , all outputs are target module.

Refer to "About a combination of commands to turn output voltage on/off " that is after section 6.2.5 if you use another command that turn output voltage on/off.

6.2.2 MFR_OPERATION_STATE [EEh] Read Byte

PAGE

Returns the ON/OFF status of the output voltage.

bit	7	6	5	4	3	2	1	0	Remark
Initial setting	0	0	0	0	0	0	0	1	01h
Access	R	R	R	R	R	R	R	R	

No.	bit	Value	Explanation
1	bit 7-1	0000000	None
2	bit 0	0	No output
3		1	Output

If the input module is target, an error is returned.

If the instruction is executed on an output module other than the supported output modules, an error is returned.

(PAGE selection error : Refer to 6.8.8)

※Module R can Refer to 6.2.3.

6.2.3 MFR_OPERATION_SLOT [D8h] R/W Byte

This is a command to enable the output voltage. (Remote on/off function.)

With this command, the output voltages of the arbitrary slots get inhibited. The target slots are set by each bit.

Refer to "About a combination of commands to turn output voltage on/off " that is after section 6.2.5 if you use another command that turn output voltage on/off.

bit	7	6	5	4	3	2	1	0	Remark
Initial setting	0	1	1	1	1	1	1	1	7Fh
Access	R	R/W	R/W	R/W	R/W	R/W	R/W	R/W	

※ The bit for blank slot is "0".

Value of each bit	Value:1 ⇒ Output
	Value:0 ⇒ No output

No.	bit	Explanation
1	bit7	None
2	bit6	Slot 6 is target.
3	bit5	Slot 5 is target.
4	bit4	Slot 4 is target.
5	bit3	Slot 3 is target.
6	bit2	Slot 2 is target.
7	bit1	Slot 1 is target.
8	bit0	All slots are target.

※It cannot be set for AME400F and AME600F.The default value is "0".

When the outputs of all slots are turned ON in item No. 8, the output keeps enabled the output keep ON regardless of the setting of each slot.

6.2.4 MFR_GI [D7h] R/W Byte

This command gets the GI activated.

When the GI activates , the built-in fan and all outputs excluding AUX power stop.

bit	7	6	5	4	3	2	1	0	備考
Initial setting	0	0	0	0	0	0	1	1	01h
Access	R	R	R	R	R	R/W	R	R/W	

No.	bit	Value	Explanation
1	bit 7-3	00000	None
2	bit 2	0	GI terminal function : GI
3		1	GI terminal function : RC (Only the module stopped by function RC)
4	bit 1	0	state of "GI"(all outputs excluding the AUX power)
5		1	Normal output
6	bit 0	0	state of "GI"(all outputs excluding the AUX power)
7		1	Normal output

This cannot enable any output which have been inhibited by the GI terminal.

And, this cannot enable any output which have been inhibited by the remote on/off function.

Refer to "About a combination of commands to turn output voltage on/off " that is after section 6.2.5 if you use another command that turn output voltage on/off.

6.2.5 MFR_CTL_RESET_LATCH [E1h] Send

This command deactivates the latch that have been activated by OVP, etc.

About a combination of commands to turn output voltage on/off

There are several commands to turn output voltage on/off, (Table 6.2.1) combination of which include unavailable usage.

Table 6.2.2 shows whether the output voltage is turned on when the command is transmitted to turn output voltage on after another command transmitted to turn output voltage off.

Table 6.2.1 The list of commands to turn output voltage on/off

No.	Item	bit7-0	PAGE[00h] bit	Explanation	Mode
1	Operation[01h]	1000XXXX	00000000	All slots ON	Start①
2	Operation[01h]	1000XXXX	00000YYY ※1	Each slots ON	Start②
3	MFR_OPERATION_SLOT[D8h]	00000001	No set target	All slots ON	Start④
4	MFR_OPERATION_SLOT[D8h]	0YYYYYYY ※1		Each slots ON	Start⑥
5	MFR_GI[D7h]	00000001		All slots ON	Start◎
6	Operation[01h]	00XXXXXX	00000000	All/each slots OFF with no sequence	Stop①
7	Operation[01h]	00XXXXXX	00000YYY ※1		Stop②
8	Operation[01h]	01XXXXXX	00000000	All/each slots OFF with sequence	Stop③
9	Operation[01h]	01XXXXXX	00000YYY ※1		Stop④
10	MFR_OPERATION_SLOT[D8h]	00000000	No set target	All slots OFF	Stop④
11	MFR_OPERATION_SLOT[D8h]	0YYYYYYY ※1		Each slots OFF	Stop⑥
12	MFR_GI[D7h]	00000000		state of "GI"	Stop◎

XX:Ignore

YY:0 or 1

※1 means setting each slot

Table 6.2.2 The combinations of commands to turn on/off

(○ : able to start × : not able to start)

No.	Mode	Start①	Start②	Start④	Start⑥	Start◎
1	Stop①	○ ₁	×	×	×	×
2	Stop②	○ ₁	○ ₁	○ ₂	○ ₂	×
3	Stop③	○ ₁	×	×	×	×
4	Stop④	○ ₁	○ ₁	○ ₁	○ ₁	×
5	Stop④	○ ₁	○ ₁	○ ₁	○ ₁	×
6	Stop⑥	○ ₁	○ ₁	○ ₁	○ ₁	×
7	Stop◎	×	×	×	×	○ ₁

○₁ : starting up usually

○₂ : starting up remaining last command with no sequence(Refer to Table 6.2.3)

Table 6.2.3 shows whether usual state and the states indicated in table 6.2.2 are able to be turned off with sequence of TOFF_DELAY[64h].

Table 6.2.3 Having sequence or not when turned off

(○ : turned off with sequence × : turned off with no sequence)

No.	state	The commands to turn output voltage off			
		Stop①/②	Stop③/④	Stop⑤/⑥	Stop⑦
1	usual state/○ ₁ state at table 6.2.2	×	○	○	○
2	○ ₂ state at table 6.2.2	×	○	×	×

6.3 Commands to set output voltage

The target of commands to set the output voltage is the output module.

If the input module is target, an error is returned.

If the instruction is executed on an output module other than the supported output modules, an error is returned.
(PAGE selection error : Refer to 6.8.8)

If a value outside the settable range is entered, an error is returned.

(Unsupported data : Refer to 6.8.7)

6.3.1 VOUT_MODE [20h] Read Byte

PAGE

It reads an output voltage format form.

No.	bit	Value	Explanation
1	bit7-5	000	Vo format is linear mode
2		001	Vo format is VID mode (not supported)
3		010	Vo format is Direct mode (not supported)
4	bit4-0	10111	It shows the index parts N of the Linear mode by 2 of complement
		10110	

6.3.2 VOUT_COMMAND [21h] R/W Word

PAGE

This command sets the output voltage.

The minimum setting unit is 0.001V (output module V is 0.01V).

When "Output voltage setting by VTRM terminal" function is enabled, this command does not work.

It cannot be set to the value which exceeds the upper limit of the output voltage adjustment range.

It cannot be set to the value which exceeds the upper limit that have been set by "SET_VOUT_UPPER_LIMIT"

It cannot be set to the value which exceeds the lower limit that have been set by "SET_VOUT_LOWER_LIMIT"

Display format	Linear (Vout)
----------------	---------------

The output voltage is set by this command regardless of the voltage adjustment by the internal potentiometer.

The output voltage can be adjusted by the internal potentiometer even after this command has been transmitted.

If the input voltage was shut off, the output voltage set by this command is reset but the one set by the potentiometer remains.

Table 6.3.1 "VOUT_COMMAND" Operation example (AM06-xxxB)

Operation	Slot1 Output	Remark
1 Power on	12.0V	
2 Adjust output voltage to 12.3V by volume	12.3V	+0.3V by volume
3 PAGE でスロット1を選択	12.3V	
4 Send "VOUT_COMMAND" & "10000"	10.0V	
5 Adjust output voltage to 10.2V by volume	10.2V	+0.2V by volume
6 Input voltage off	0V	+0.3V & +0.2V => +0.5V
7 Input voltage on	12.5V	+0.3V & +0.2V => +0.5V

6.3.3 MFR_VOUT_FACTORY_SETTING [E3h] Send

PAGE

This command restores the output voltage set by "SET_VOUT" command to the factory default value.

This command does not reset the adjustment by the internal potentiometer.

Table 6.3.2 "MFR_VOUT_FACTORY_SETTING" Operation example (AM06-xxxB)

Operation	Slot1 Output	Remark
1 Power on	12.0V	
2 Adjust output voltage to 12.3V by volume	12.3V	+0.3V by volume
3 PAGE でスロット1を選択	12.3V	
4 Send "VOUT_COMMAND" & "10000"	10.0V	
5 Adjust output voltage to 10.2V by volume	10.2V	+0.2V by volume
6 Send "MFR_VOUT_FACTORY_SETTING"	12.5V	+0.3V & +0.2V => +0.5V

The value of the output voltage that has been stored in the non-volatile memory by "SYS_STORE_USER_SETTING" command does not change.

6.3.4 MFR_VOUT_REFERENCE [EAh] Read Word

PAGE

This command returns the controlling value for the output voltage.

Display format	Linear (Vout)
----------------	---------------

* If the state has changed by volume adjustment, etc., the return value will be different from the value set by "SET_VOUT".

6.3.5 VOUT_MAX [24h] R/W Word

PAGE

This command sets a upper limit for the output voltage adjustment range.

The minimum setting unit is 0.1V (output module V is 1V).

This setting is applied to all operations related to the voltage adjustment (Internal potentiometer, VTRM terminal, "VOUT_COMMAND [21h]" command).

The voltage exceeding this upper limit is not outputted even in the constant current operation.

When the specified value is lower than the output voltage, the output voltage changes to the specified value.

It cannot be set to the value which is the lower limit which has been set by "MFR_VOUT_MIN [D3h]" or less.

It cannot be set to the value which exceeds the upper limit of the output voltage adjustment range.

Display format	Linear (Vout)
----------------	---------------

6.3.6 MFR_VOUT_MIN [D3h] R/W Word

PAGE

This command sets a lower limit for the output voltage adjustment range.

The minimum setting unit is 0.1V (output module V is 1V).

This setting is applied to all operations related to the voltage adjustment (Internal potentiometer, VTRM terminal, "VOUT_COMMAND [21h]" command).

During the constant current operation, the output voltage may get lower than this value.

It cannot be set to the value which is the upper limit which has been set by "VOUT_MAX [24h]" or more.

Display format	Linear (Vout)
----------------	---------------

6.3.7 MFR_VOUT_LIMIT_FACTORY_SETTING [E5h] Send

PAGE

This command restores the value set by "VOUT_MAX [24h]" and "MFR_VOUT_MIN [D3h]" to the factory defaults.

The value of the upper and lower limit of the output voltage that have been stored in the non-volatile memory by "SYS_STORE_USER_SETTING" command does not change.

6.4 Commands to set constant current

The target of commands to set the constant current is the output module.

If the input module is target, an error is returned.

If the instruction is executed on an output module other than the supported output modules, an error is returned.
(PAGE selection error : Refer to 6.8.8)

If a value outside the settable range is entered, an error is returned.

(Unsupported data : Refer to 6.8.7)

Modules in parallel cannot be used with the constant current operation. (This command cannot be used for parallel operation.)

6.4.1 MFR_CC_MODE [D1h] R/W Byte

PAGE

Setting method for constant current operation.

bit	7	6	5	4	3	2	1	0	Remark
Initial setting	0	0	0	0	0	0	0	0	00h
Access	R	R	R	R	R	R	R	R/W	

No.	bit	Value	Explanation
1	bit 7-1	0000000	None
2	bit 0	0	Sets by Itrm terminal
3		1	Sets by MFR_CC [D0h] command

6.4.2 MFR_CC [D0h] R/W Word

PAGE

This command sets the value for the constant current.

It cannot be set to the value which exceeds the upper limit that have been set by "MFR_CC_MAX [D2h]" command.

It cannot be set to the value which exceeds the rated current.

Display format	Linear (Iout)
----------------	---------------

The factory default is that the constant current can be set by the voltage on the ITRM terminal.

The value set by this command get enabled if "MRF_CC_MODE [D1h] " command is transmitted.

The order of transmitting "MRF_CC_MODE [D1h] "MFR_CC [D0h] " command is no object.

6.4.3 MFR_CC_FACTORY_SETTING [E4h] Send

PAGE

This command restores the value of the constant current set by "MFR_CC [D0h]" command to the factory default.

The value of the constant current that has been stored in the non-volatile memory by "STORE_USER_ALL [15h]" command does not change.

6.4.4 MFR_CC_REFERENCE [EBh] Read Word

PAGE

This command returns the controlling value for the constant current.

Display format	Linear (Iout)
----------------	---------------

* If the state has changed by any protection, etc., the return value will be different from the value set by "SET_CC".

6.4.5 MFR_CC_MAX [D2h] R/W Word

PAGE

This command sets the upper limit of the setting of the constant current.

The minimum setting unit is 0.1A.

When the specified value is lower than the controlling value of the constant current, the constant current changes to the specified value.

It cannot be set to the value which exceeds the rated current.

Display format	Linear (Iout)
----------------	---------------

6.4.6 MFR_CC_LIMIT_FACTORY_SETTING [E6h] Send

PAGE

This command restores the value set by "SET_CC_LIMIT" command to the factory default.

The upper limit of the constant current that has been stored in the non-volatile memory by "STORE_USER_ALL [15h]" command does not change.

6.4.7 MFR_CC_CONTROL [DFh] R/W Byte

PAGE

This command sets a controlled variable of the constant current.

When the constant current is set by "MFR_CC_MODE [D1h]" command, etc, the time to the setting value can be selected. The larger the control amount adjusts the constant current to the setting value faster.)

This setting is enabled under the constant current operation.

bit	7	6	5	4	3	2	1	0	Remark
Initial setting	0	0	0	0	0	0	0	0	00h
Access	R	R	R	R	R	R/W	R/W	R/W	

No.	bit	Settable range	Status
1	bit 7-0	00000000	Default
2		00000001	Default × 0.2 (Slow)
3		00000010	Default × 2 (Fast)
4		00000011	Default × 4 (Fast)
5		00000100	Default × 28.8 (Very Fast)

6.5 Commands to set output voltage sequence

If a value outside the settable range is entered, an error is returned.

(Unsupported data : Refer to 6.8.7)

6.5.1 MFR_TON_DELAY_SLOT [D9h] R/W Word

PAGE

This command sets the value of the delay time, in ms, from when power conversion is ready to when it starts. (See Figure 6.5.1.)

The setting by this command causes a delay due to the processing time of the slave which is the AME series.

This is enabled at AC input with power conversion ready, but the internal delay of up to 800ms occurs.

The factory default is "0".

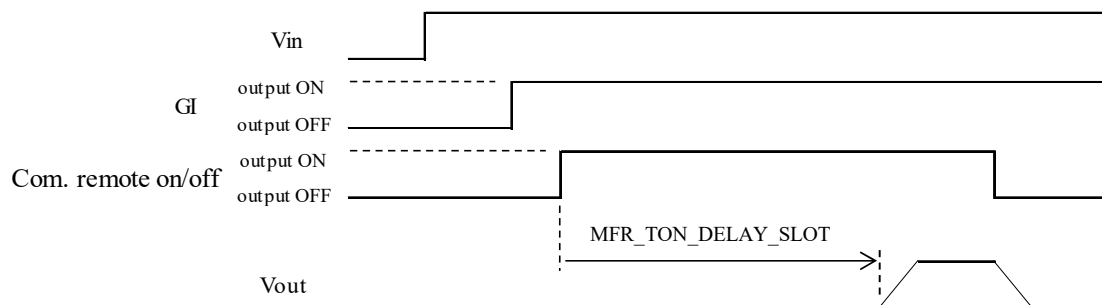

*The power conversion starts after delay time set by "MFR_TON_DELAY_SLOT" command when conditions such as AC input, disabling the GI and enabling the Remote ON are met.

Figure 6.5.1 Timing diagram of "SET_TON_DELAY_SLOT"

Specified range	0 - 30016
Display format	Linear (Time_2)

Since the data format is Linear (Time_2), the setting range is input every "32".

No delay time is set for the RC terminal of each output module.

If the front-end module is target, an error is returned.

(Error code 6 : Command that do not correspond to the setting target)

6.5.2 MFR_TON_DELAY_SLOT_FACTORY_SETTING [E7h] Send

This command restores the delay time to power-on set by "MFR_TON_DELAY_SLOT" command for all slots to the factory default.

The delay time to power-on that has been stored in the non-volatile memory by "STORE_USER_ALL [15h]" command does not change.

6.5.3 TOFF_DELAY [64h] R/W Word

This command sets the value of the delay time, in ms, from when a stop signal which is the GI or the communication signal of the module inhibit is received to when power conversion stops. (See Figure 6.5.2.)

The setting by this command causes a delay due to the processing time of the slave which is the AME series.

The factory default is "0".

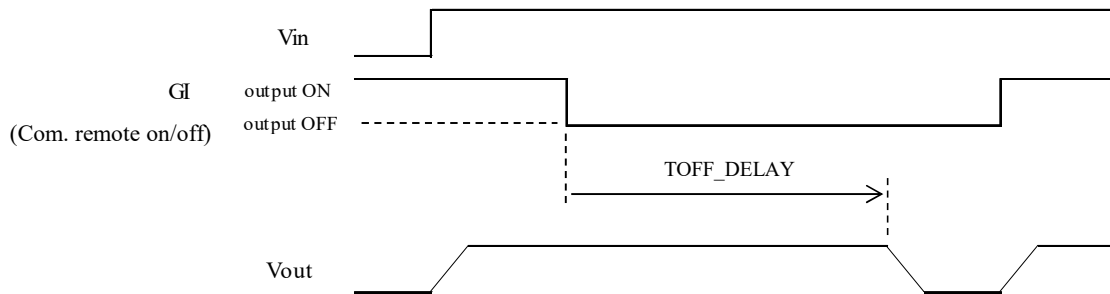

*The power conversion stops after delay time set by "TOFF_DELAY" command, when meeting the stop-condition by the GI or communication remote on/off.

Figure 6.5.2 Timing diagram of "SET_TOFF_DELAY_SLOT"

Specified range	0 - 30016
Display format	Linear (Time_2)

Since the data format is Linear (Time_2), the setting range is input every "32".

No delay time is set for the RC terminal of each output module.

No delay time is set under conditions which the power conversion cannot be maintained like the lower input voltage than the stop voltage.

If the front-end module is target, an error is returned.

(Error code 6 : Command that do not correspond to the setting target)

6.5.4 MFR_TOFF_DELAY_FACTORY_SETTING [E8h] Send

This command restores the delay time to power-off set by "TOFF_DELAY" command for all slots to the factory default.

The delay time to power-off that has been stored in the non-volatile memory by "SYS_STORE_USER_SETTING" command does not change.

6.5.5 MFR_TON_DELAY_VIN [DAh] R/W Word

This command sets the delay time, in ms, from power-on to when power conversion starts. (See Figure 6.5.3.)

The factory default is the value of the specification for the start-up time.

Store the setting value by "STORE_USER_ALL [15h]" command after this command is transmitted. Then, wait for 30 seconds or more after power-off. The setting will get enabled from next start-up.

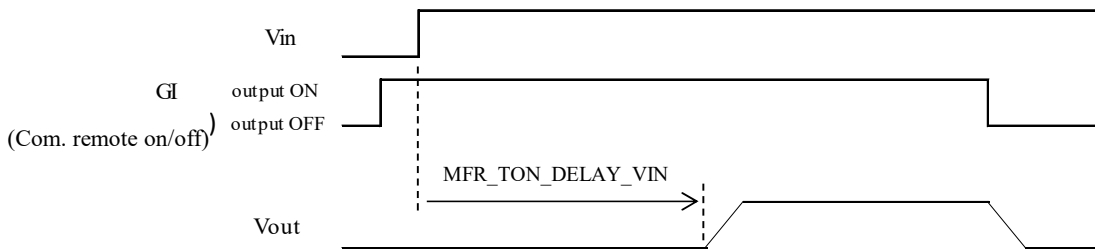
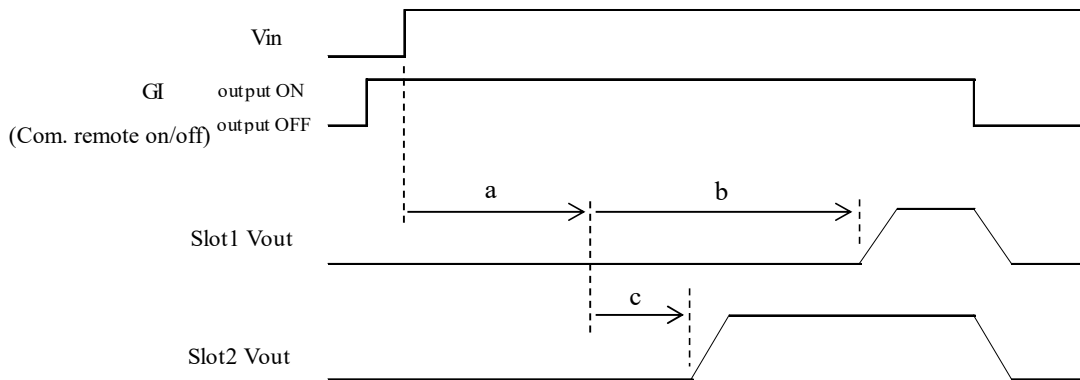

Figure 6.5.3 Timing diagram of "SET_TON_DELAY_VIN"

Specified range	768 - 60032
Display format	Linear (Time_1)

Since the data format is Linear (Time_1), the setting range is input every "64".

When the delay time is set by the "MFR_TON_DELAY_SLOT" command, its operation starts after the one by "MFR_TON_DELAY_VIN" command. (See Fig. 6.5.4.)



	MFR_TON_DELAY_VIN	MFR_TON_DELAY_SLOT
Slot1		b
Slot2	a	c

Figure 6.5.4 Timing diagram for "MFR_TON_DELAY_VIN" and "MFR_TON_DELAY_SLOT"

6.5.6 MFR_RAMP_RATE [DBh] R/W Byte

This command sets a ramp rate of the output voltage.

The setting is enabled for the start-up by power-on or the remote-on" and "the output voltage adjustment by the VTRM terminal or "VOUT_COMMAND [21h]" command.

The factory default is "0".

bit	7	6	5	4	3	2	1	0	Remark
Initial setting	0	0	0	0	0	0	0	0	00h
Access	R	R	R	R	R	R	R/W	R/W	

No.	bit	Value	Explanation
1	bit7-0	00000000	Default (Fast)
2		00000001	10%-90%(rated voltage) / approx.50 msec (Slow)
3		00000010	10%-90%(rated voltage) / approx.280 msec (Very Slow)

If the input module is target, an error is returned.

If the instruction is executed on an output module other than the supported output modules, an error is returned.

(PAGE selection error : Refer to 6.8.8)

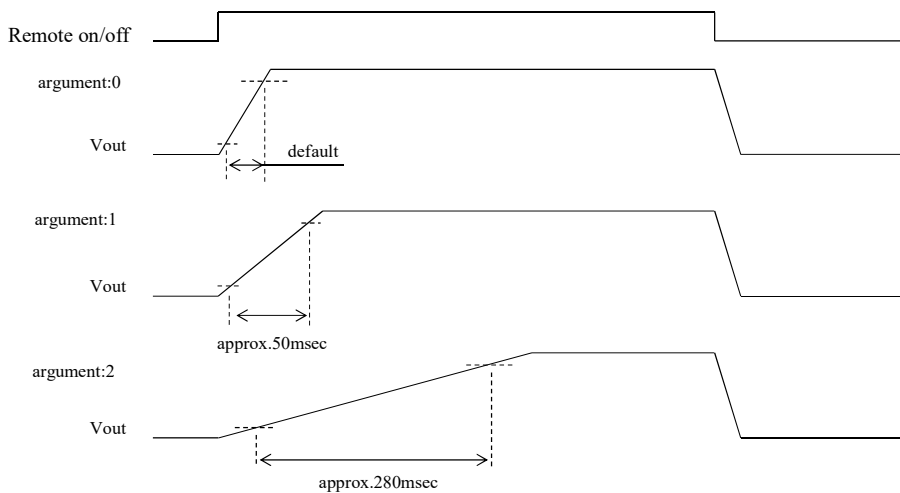

Figure 6.5.5 Activation chart by Remote ON/OFF terminal

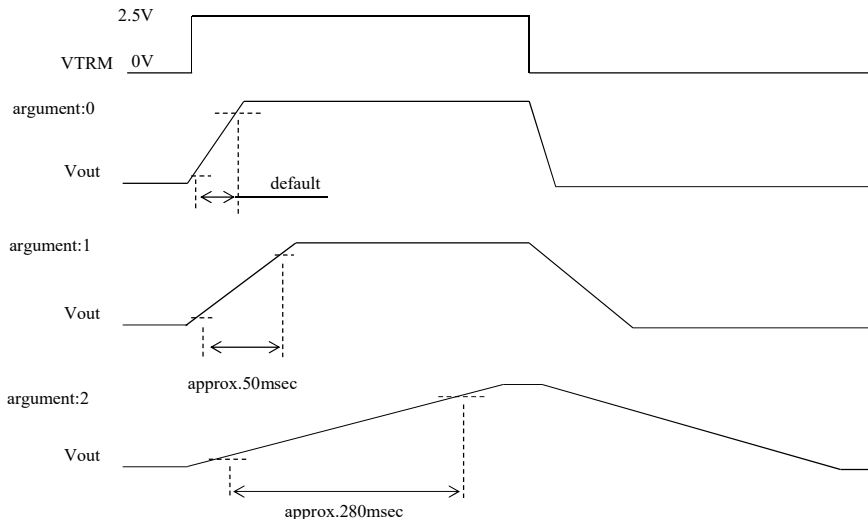

Figure 6.5.6 Activation chart by the VTRM terminal

6.5.7 VIN_ON [35h] R/W Word

This command sets the starting voltage for the AC input.

Store the setting value by "STORE_USER_ALL [15h]" command after this command is transmitted.

Then, wait for 30 seconds or more after power-off. The setting will get enabled from next start-up.

With this command, the starting voltage cannot be set to the value which is lower than 5V higher value than the one by "VIN_OFF [36h]" command. If specified, this command is not accepted and an error is returned.

Specified range	80 - 240VAC
Display format	Linear (Vin)

When the input voltage is 90VAC or less, load derating is required. Refer the AME series instruction manual for the detail.

6.5.8 VIN_OFF [36h] R/W Word

This command sets the stopping voltage for the AC input.

Store the setting value by "STORE_USER_ALL [15h]" command after this command is transmitted.

Then, wait for 30 seconds or more after power-off. The setting will get enabled from next start-up.

With this command, the starting voltage cannot be set to the value which is higher than 5V lower value than the one by "VIN_ON [35h]" command. If specified, this command is not accepted and an error is returned.

Specified range	75 - 150VAC
Display format	Linear (Vin)

When the input voltage is 90VAC or less, load derating is required. Refer the AME series instruction manual for the detail.

6.6 Commands to set accessory functions

If a value outside the settable range is entered, an error is returned.

(Unsupported data : Refer to 6.8.7)

6.6.1 MFR_FAN_MODE [D6h] R/W Byte

This command makes the rotation speed of the built-in air-cooling fan be controlled automatically.

This is the factory default.

bit	7	6	5	4	3	2	1	0	Remark
Initial setting	0	0	0	0	0	0	0	0	00h
Access	R	R	R	R	R	R	R	R/W	

No.	bit	Value	Explanation
1	bit 7-1	0000000	None
2	bit 0	0	Automatic control of the rotation speed of the built-in air cooling fan
3		1	Fixes the rotation speed of the built-in air cooling fan at the maximum.

6.6.2 MFR_AUX_VOUT [DCh] R/W Word

This command sets the output voltage for the AUX power.

The minimum setting unit is 0.1V.

The factory default is 5V.

Specified range	4.7 - 12.6V
Display format	Linear (Vout)

The rated output current of AUX changes with the output voltage. (See Figure 6.6.1.)

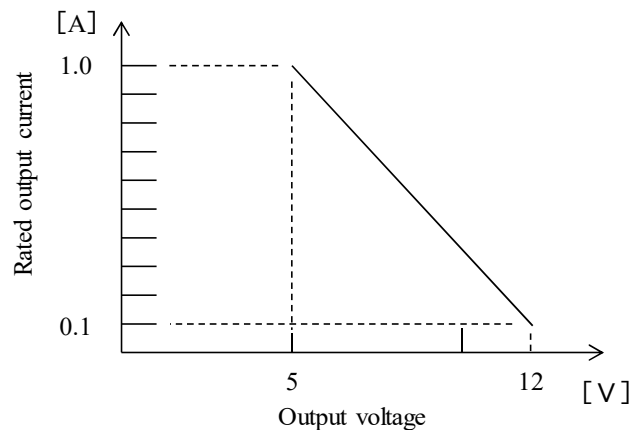

Figure 6.6.1 The rated output current of AUX (AME series)

6.6.3 VIN_UV_WARN_LIMIT [58h] R/W Word

This command sets the input threshold voltage for the alarm signal from PR terminal.

It sets the argument to the input voltage, in V, for the alarm signal which detects lower input voltage.

Specified range	75 - 240VAC
Display format	Linear (Vin)

6.7 Monitor commands

6.7.1 READ_VIN [88h] Read Word

This command returns the RMS value of the input voltage. It discriminates DC from AC automatically. If the input voltage was distorted, the return value may not be correct.

Display format	Linear (Vin)
----------------	--------------

6.7.2 MFR_READ_VIN_FREQUENCY [E9h] Read Word

This command returns the frequency of the input voltage.
When the input is "DC", the return value is "0".
It will be unsettled for five seconds from power-on.

Display format	Linear(Vin_Freq)
----------------	------------------

6.7.3 READ_VOUT [8Bh] Read Word

This command returns the output voltage (voltage between the output terminals).

PAGE

Display format	Linear (Vout)
----------------	---------------

If the input module is target, an error is returned.

If the instruction is executed on an output module other than the supported output modules, an error is returned.

(PAGE selection error : Refer to 6.8.8)

6.7.4 READ_IOUT [8Ch] Read Word

This command returns the output current.

PAGE

Display format	Linear (Iout)
----------------	---------------

If the input module is target, an error is returned.

If the instruction is executed on an output module other than the supported output modules, an error is returned.

(PAGE selection error : Refer to 6.8.8)

6.7.5 READ_POUT [96h] Read Word

This command returns the output power.

PAGE

Display format	Linear (Pout)
----------------	---------------

If the input module is target, an error is returned.

If the instruction is executed on an output module other than the supported output modules, an error is returned.

(PAGE selection error : Refer to 6.8.8)

6.7.6 READ_FAN_SPEED_1 [90h] Read Word

This command returns This command returns the fan speed of the internal air-cooling fan 1.

Display format	Linear (Fan)
----------------	--------------

Since the data format is Linear (Fan), the reading range is a value for each "32".

6.7.7 READ_FAN_SPEED_2 [91h] Read Word

This command returns This command returns the fan speed of the internal air-cooling fan 2.

Display format	Linear (Fan)
----------------	--------------

Since the data format is Linear (Fan), the reading range is a value in multiples of "32".

When this command is transmitted to AME400F or AME600F , An error occur.

(Unsupported data : Refer to 6.8.7)

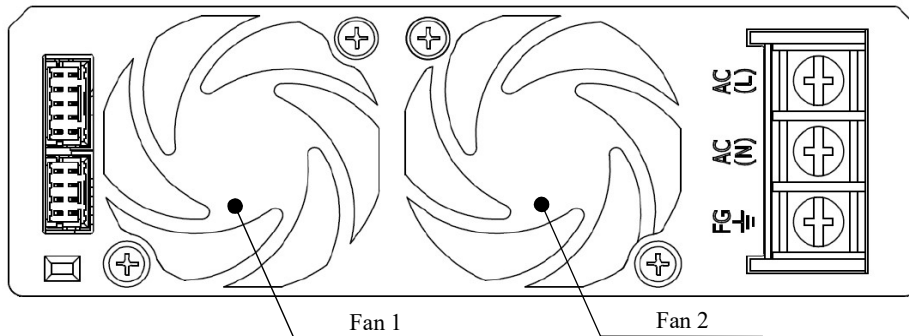

Figure 6.7.1 Position of fans in AME800F or AME1200F (Front view)

6.7.8 READ_TEMPERATURE_1 [8Dh] Read Word

This command returns the temperature near the fan in the unit.

Display format	Linear (Temp)
----------------	---------------

6.8 State acquisition commands

6.8.1 CLEAR_FAULTS [03h] Send

This command is used to clear the "STATUS Register" after any fault occurs and reset the SMBALERT signal.

6.8.2 SMBALERT_MASK [1Bh] Write Word / Block Write - Read Process Call

The SMBALERT_MASK command may be used to prevent a warning or fault condition from asserting the SMBALERT signal. That is set to "1" to the bit to be masked.

No.	Status command of possible mask setting	Code	Word/Byte	Initial value
1	STATUS_BYTE	78h	Byte	02h
2	STATUS_WORD(上位8bit)	79h	Byte	10h
3	STATUS_INPUT	7Ch	Byte	00h
4	STATUS_TEMPERATURE	7Dh	Byte	00h
5	STATUS_CML	7Eh	Byte	FFh
6	STATUS_MFR_SPECIFIC	80h	Byte	01h
7	STATUS_FANS_1_2	81h	Byte	00h

The details of the data format is described in PMBus standard specification manual: PMBus Power System Management Protocol Specification Part II . BLOCK COUNT be always set to "1"

6.8.3 STATUS_BYTE [78h] R/W Byte

This command read the error state.

Error is cleared by writing a 1 to the error bit (only bit7). All of the error bit is cleared in CLEAR_FAULTS [03h].

Initial setting :00h

項番	bit	Explanation
1	bit7	It sets when the device can not reply in use.
2	bit6	It sets by output OFF status (not supportive).
3	bit5	An output overvoltage fault has occurred (not supportive).
4	bit4	An output overcurrent fault(intermittent current protection) has occurred (not supportive).
5	bit3	An input under voltage fault has occurred (not supportive).
6	bit2	A temperature fault has occurred (STATUS_TEMPERATURE [7Dh])
7	bit1	A communications, memory or logic fault has occurred (STATUS_CML [7Eh])
8	bit0	A fault or warning not listed in bits [7:1] has occurred (not supportive).

6.8.4 STATUS_WORD [79h] R/W Word

This command read the error state.

Error is cleared by writing a 1 to the error (only bit8) bit. All of the error bit is cleared in CLEAR_FAULTS [03h].

Initial setting :00h

No.	bit	Explanation
1	bit15	An output voltage fault has occurred (STATUS_VOUT [7Ah]).
2	bit14	An output current fault has occurred (STATUS_IOUT [7Bh])
3	bit13	An input voltage fault has occurred (STATUS_INPUT [7Ch]).
4	bit12	A manufacturer specific fault has occurred (STATUS_MFR_SPECIFIC [80h])
5	bit11	POWER_GOOD signal is output (not supportive).
6	bit10	A fan or airflow fault has occurred (STATUS_FANS_1_2 [81h])
7	bit9	A bit in STATUS_OTHER is set (not supportive).
8	bit8	A fault type not given in bits [15:1] of the SATUS_WORD has been.
9	bit7-0	Same STATUS_BYTE [78h].

6.8.5 STATUS_INPUT [7Ch] R/W Byte

This command read the input error state.

Error is cleared by writing a 1 to the error bit. All of the error bit is cleared in CLEAR_FAULTS [03h].

Initial setting :00h

No.	bit	Explanation
1	bit7	Input voltage is set to higher than VIN_OV_FAULT_LIMIT [55h] (Unsupported).
2	bit6	Input voltage is set to higher than VIN_OV_WARN_LIMIT [57h] (Unsupported).
3	bit5	Input voltage is set to lower than VIN_UV_WARN_LIMIT [58h]
4	bit4	Input voltage is set to higher than VIN_UV_FAULT_LIMIT [59h] (Unsupported).
5	bit3	AME stopped due to insufficient input voltage (not supportive).
6	bit2	Input current is set to higher than IIN_OC_FAULT_LIMIT (Unsupported).
7	bit1	Input current is set to higher than IIN_OC_WARN_LIMIT (Unsupported).
8	bit0	Input current is set to higher than PIN_OC_WARN_LIMIT (Unsupported).

6.8.6 STATUS_TEMPERATURE [7Dh] R/W Byte

This command read the temperature error state.

Error is cleared by writing a 1 to the error bit. All of the error bit is cleared in CLEAR_FAULTS [03h].

This command is applied to only the OTP operation of the input module.

STATUS_MFR_SPECIFIC [80h] is set for Thermal protection operation of the output module,

Initial setting :00h

No.	bit	Explanation
1	bit7	OT_FAULT
2	bit6	OT_WARNING (not supportive).
3	bit5	UT_WARNING (not supportive).
4	bit4	UT_FAULT (not supportive).
5	bit3	–
6	bit2	–
7	bit1	–
8	bit0	–

6.8.7 STATUS_CML [7Eh] R/W Byte

This command read the communication error state.

Error is cleared by writing a 1 to the error bit. All of the error bit is cleared in CLEAR_FAULTS [03h].

Initial setting :00h

No.	bit	Explanation
1	bit7	Invalid Or Unsupported Command Received
2	bit6	Invalid Or Unsupported DATA Received
3	bit5	Packet Error Check Failed
4	bit4	Memory Fault Detected (not supportive)
5	bit3	Processor Fault Detected
6	bit2	—
7	bit1	A communication fault other than the ones listed in this table has occurred
8	bit0	—

6.8.8 STATUS_MFR_SPECIFIC [80h] R/W Byte

This command read the specific error state .

Error is cleared by writing a 1 to the error bit. All of the error bit is cleared in CLEAR_FAULTS [03h]

Initial setting :00h

No.	bit	Explanation
1	bit7	—
2	bit6	—
3	bit5	—
4	bit4	—
5	bit3	—
6	bit2	OPP(over power protection) of the front-end module activates.
7	bit1	OTP(over thermal protection) or OVP(over voltage protection) of the output module activates.
8	bit0	PAGE selection error occurs.

6.8.9 STATUS_FANS_1_2 [81h] R/W Byte

This command read the built-in air cooling fan error state.

Error is cleared by writing a 1 to the error bit. All of the error bit is cleared in CLEAR_FAULTS [03h]

Initial setting :00h

No.	bit	Explanation
1	bit7	Fan 1 Fault
2	bit6	Fan 2 Fault (not supportive)
3	bit5	Fan 1 Warning (not supportive)
4	bit4	Fan 2 Warning (not supportive)
5	bit3	Fan 1 Speed Overridden (not supportive)
6	bit2	Fan 2 Speed Overridden (not supportive)
7	bit1	Airflow Fault (not supportive)
8	bit0	Airflow Warning (not supportive)

6.8.10 MFR_ARA_CONFIG [E0h] R/W Byte

This command sets the SMBALERT configure.

bit	7	6	5	4	3	2	1	0	Remark
Initial setting	0	0	0	0	0	0	0	0	00h
Access	R	R	R	R/W	R	R	R	R	

No.	bit	Value	Explanation
1	bit7-5	000	None
2	bit4	0	It does not change the address at the time of SMBALERT signal output
3		1	It do change the ARA address at the time of SMBALERT signal output
4	bit3-0	0000	None

6.8.11 MFR_STOP_CODE [FCh] Read Byte

PAGE

This command returns the code indicating the cause of the stoppage.

PAGE Setting target	Stop code	Cause of stop
Front-end module (Set value: 0)	000	No stoppage occurred.
	003	Global inhibit is activating.
	010	Stoppage due to input voltage drop.
	054	Stoppage due to abnormal fan rotation.
	062	Stoppage by overpower protection in front-end module.
	106	Stoppage by thermal protection.
	130 131	Stoppage by overvoltage or thermal protection in the output module.
Output module (Set value: 1-6)	000	No stoppage occurred.
	001	Stoppage by RC terminal.
	013	Stoppage by command from input module. (Module inhibit by communication, etc.)
	050	Stoppage by activation of overcurrent protection.
	051	
071		

If the stop code is not listed above, the unit may be failure.

If the output module is stopped due to an input module stop, the command to the slot will be error.

If the instruction is executed on an output module other than the corresponding output modules, an error is returned.

6.8.12 MFR_READ_TOTAL_INPUT_TIME

This command returns the accumulated time for application of the input voltage stored in the non-volatile memory of the AME.

The returned value of "MFR_READ_TOTAL_INPUT_TIME_1" represents "minute" and it is reset to "0" every 60 minutes.

The returned value of "MFR_READ_TOTAL_INPUT_TIME_2" represents low 16 bits and the one of "MFR_READ_TOTAL_INPUT_TIME_3" represents high 16 bits. And, those 32 bits are returned as the accumulated time for the application of the input voltage, in hour.

The data may not be stored for less than one minute before power-off.

MFR_READ_TOTAL_INPUT_TIME_1 [EFh] Read Word

Range	0 - 59 minute
-------	---------------

MFR_READ_TOTAL_INPUT_TIME_2 [F0h] Read Word**MFR_READ_TOTAL_INPUT_TIME_3 [F1h] Read Word**

Range	0 - 232-1 hour (Theoretical value)		
Constitution	Low 16 bits	:TOTAL_INPUT_TIME_2	(0 - 65,535 hour)
	High 16 bits	:TOTAL_INPUT_TIME_3	

6.8.13 MFR_READ_TOTAL_OUTPUT_TIME

PAGE

This command returns the accumulated time for outputs stored in the non-volatile memory of the AME.

If the front-end module is selected, the accumulated time for output of the front-end module is returned.

If a slot is selected, the accumulated time for output of the output module is returned.

The returned value of "MFR_READ_TOTAL_OUTPUT_TIME_1" represents "minute" and it is reset to "0" every 60 minutes.

The returned value of "MFR_READ_TOTAL_OUTPUT_TIME_2" represents low 16 bits and the one of "MFR_READ_TOTAL_OUTPUT_TIME_3" represents high 16 bits. And, those 32 bits are returned as the accumulated time for the application of the input voltage, in hour.

The data may not be stored for less than one minute before power-off.

MFR_READ_TOTAL_OUTPUT_TIME_1 [F2h] Read Word

Range	0 - 59 minute
-------	---------------

MFR_READ_TOTAL_OUTPUT_TIME_2 [F3h] Read Word**MFR_READ_TOTAL_OUTPUT_TIME_3 [F4h] Read Word**

Range	0 - 2 ³² -1 hour (Theoretical value)		
Constitution	Low 16 bits	:TOTAL_INPUT_TIME_2	(0 - 65,535 hour)
	High 16 bits	:TOTAL_INPUT_TIME_3	

6.9 Commands to set address, memory, and communication

6.9.1 PAGE [00h] R/W Byte

By selecting the input module or target slot with this command and sending the corresponding command, it is possible to set the selected target and return the setting status.

The factory default is the front-end module.

The following symbol mark is displayed on commands that assume input of this command.

PAGE

Example:

6.2.1 OPERATION [01h] R/W Byte

This is a command to enable the output voltage. (Remote on/off function.)

PAGE

The command corresponding to this command is shown below.

PAGE Corresponding commands			
6.2 Commands to turn output voltage on/off			
1	OPERATION	01h	:Enabling or disabling the output in the selected slot.
2	MFR_OPERATION_STATE	EEh	:Returns the output ON/OFF status
6.3 Commands to set output voltage			
1	VOUT_MODE	20h	:Returns an output voltage format form.
2	VOUT_COMMAND	21h	:Setting the output voltage in the selected slot.
3	MFR_VOUT_FACTORY_SETTING	E3h	:Returning a factory setting for the output voltage in the selected slot.
4	MFR_VOUT_REFERENCE	EAh	:Returning the controlling value for the output voltage in the selected slot.
5	VOUT_MAX	24h	:Setting a upper limit for the output voltage in the selected slot adjustment range.
6	MFR_VOUT_MIN	D3h	:Setting a lower limit for the output voltage in the selected slot adjustment range.
7	MFR_VOUT_LIMIT_FACTORY_SETTING	E5h	Restoring a factory default value of a upper and a lower limit for the output voltage adjustment range in the selected slot.
6.4 Commands to set constant current			
1	MFR_CC_MODE	D1h	Sets the setting method of constant current in the selected slot
2	MFR_CC	D0h	:Setting a value of the constant current in the selected slot
3	MFR_CC_FACTORY_SETTING	E4h	:Restoring a factory default value of the constant current in the selected slot.
4	MFR_CC_REFERENCE	EBh	:Returning the controlling value for the constant current in the selected slot.
5	MFR_CC_MAX	D2h	:Setting a upper limit for the constant current in the selected slot adjustment range.
6	MFR_CC_LIMIT_FACTORY_SETTING	E6h	:Restoring a factory default value of a upper limit for the constant current in the selected slot.
7	MFR_CC_CONTROL	DFh	:Setting a controlled variable of the constant current in the selected slot.
6.5 Commands to set output voltage sequence			
1	MFR_TON_DELAY_SLOT	D9h	:Setting a power-on delay time in the selected slot.
3	TOFF_DELAY	64h	:Setting a power-off delay time in the selected slot.
6	MFR_RAMP_RATE	DBh	:Setting a ramp rate of the output voltage in the select slot.
6.7 Monitor commands			
3	READ_VOUT	8Bh	:Returning a value of the output voltage in the select slot.
4	READ_IOUT	8Ch	:Returning a value of the output current in the select slot.
5	READ_POUT	96h	:Returning a value of the output power in the select slot.

PAGE Corresponding commands			
6.8 State acquisition commands			
11	MFR_STOP_CODE	FCh	:Clear the" STATUS Register" after any fault occurs and reset the SMBALERT signal
13	MFR_READ_TOTAL_OUTPUT_TIME_1	F2h	:Returning an accumulated time that the input voltage has been applied. (minute)
	MFR_READ_TOTAL_OUTPUT_TIME_2	F3h	:Returning an accumulated time that the input voltage has been applied. (low 16 bits of hour)
	MFR_READ_TOTAL_OUTPUT_TIME_3	F4h	:Returning an accumulated time that the input voltage has been applied. (high 16 bits of hour)
6.9 Commands to set address, memory, and communication			
4	STORE_USER_ALL	15h	:Storing settings into the internal non-volatile memory.
5	RESTORE_DEFAULT_ALL	12h	:Restoring a factory default for settings.
6.10 Commands to acquire product information			
3	MFR_MODEL	9Ah	:Returns the product name (ASCII)
5	MFR_RATED_VOUT	FAh	:Returning the rated voltage of the model.
6	MFR_RATED_IOUT	FBh	:Returning the rated current of the model.

Specified range	AME400F,AME600F	: 0 - 4
	AME800F,AME1200F	: 0 - 6

bit	7	6	5	4	3	2	1	0	Remark
Initial setting	0	0	0	0	0	0	0	0	00h
Access	R	R	R	R	R	R/W	R/W	R/W	

No.	bit	Value	Explanation
1	bit 7-0	00000000	Set target to input module
2		00000001	Set target to slot 1
3		00000010	Set target to slot 2
4		00000011	Set target to slot 3
5		00000100	Set target to slot 4
6		00000101	Set target to slot 5
7		00000110	Set target to slot 6

If specified to only an empty slot, this command is not accepted and an error is returned.
(PAGE selection error : Refer to 6.8.8)

Some commands based on the input of this command may or may not be supported depending on the output module. Refer to "Appendix. Availability and accuracy of Extended-UART commands" for availability.

6.9.2 CAPABILITY [19h] Read Byte

It reads the support status of the communication.

bit	7	6	5	4	3	2	1	0	Remark
Initial setting	1	0	1	1	0	0	0	0	B0h
Access	R	R	R	R	R	R	R	R	

No.	bit	Value	Explanation
1	bit7	0	Packet error check is not supportive
2		1	Packet error check is supportive
3	bit6-5	00	Supported Maximum Bus speed is 100kHz
4		01	Supported Maximum Bus speed is 400kHz
5		10	None
6		11	None
7	bit4	0	SMBALERT is not supportive
8		1	SMBALERT is supportive
9	bit3-0	0000	None

6.9.3 WRITE_PROTECT [10h] R/W Byte

Disables the Write command (see Table 6.1).

bit	7	6	5	4	3	2	1	0	Remark
Initial setting	0	0	0	0	0	0	0	0	00h
Access	R/W	R/W	R/W	R/W	R	R	R	R	

No.	bit	Value	Explanation
1	bit7-0	10000000	Writing is impossible except WRITE_PROTECT [10 h]
2		01000000	Writing is impossible except the above +OPERATION [01 h], PAGE[00h]
3		00100000	Writing is impossible except the above + VOUT_COMMAND [21 h]
4		00000000	Writing in all command to be supported is possible

6.9.4 STORE_USER_ALL [15h] Send

This command stores value and/or settings set by the communication function in the non-volatile memory of the AME.

Stored values and settings can remain even during power-off.

This command stores settings of target module selected by "PAGE" command in non-volatile memory of each module.

This command needs to be executed to every target module individually.

Commands corresponding to this command are shown below.

PAGE	STORE_USER_ALL Supported commands	
Input module (Set value: 0)	OPERATION	01h :The operation status of the output set by communication
	MFR_OPERATION_SLOT	D8h :The operation status of the output set by communication
	MFR_GI	D7h :State of "GI" set by communication
	MFR_TON_DELAY_SLOT	D9h :Value of the delay time from when power conversion is ready to when it starts.
	TOFF_DELAY	64h :Value of the delay time from when a stop signal which is the GI or the communication signal of the module inhibit
	MFR_TON_DELAY_VIN	DAh :Value of the delay time from power on
	VIN_ON	35h :Setting the starting voltage for the AC input
	VIN_OFF	36h :Setting the stopping voltage for the AC input
	MFR_FAN_MODE	D6h :Setting to switch the mode of the rotation speed for the built-in fan
	MFR_AUX_VOUT	DCh :The output voltage for the AUX power
	VIN_UV_WARN_LIMIT	58h :The input threshold voltage for the alarm signal
	SMBALERT_MASK	1Bh :Setting abnormal states of to output SMBALERT
	MFR_ARA_CONFIG	E0h :Setting status of SMBALERT function
	WRITE_PROTECT	10h :Protection setting status for write command
MFR_ACCUMULATE_MODE	F6h :Setting the Accumulate mode	
MFR_ADDRESS	D4h :Communication Address	

PAGE	STORE_USER_ALL Supported commands	
Output module (Set value: 1-6)	VOUT_COMMAND	21h :Setting value of output voltage
	VOUT_MAX	24h :Upper limit for the output voltage adjustment range
	MFR_VOUT_MIN	D3h :Lower limit for the output voltage adjustment range
	MFR_CC_MODE	D1h :Mode for constant current operation
	MFR_CC	D0h :Value for the constant current
	MFR_CC_MAX	D2h :Upper limit of the setting of the constant current
	MFR_CC_CONTROL	DFh :Controlled variable of the constant current
	MFR_RAMP_RATE	DBh :Ramp rate of the output voltage

Note: MFR_TON_DELAY_SLOT, MFR_TON_DELAY_VIN, TOFF_DELAY is the input module setting items. If you want to save, select the input module.

If the instruction is executed on an output module other than the supported output modules, an error is returned.

(PAGE selection error : Refer to 6.8.8)

Multiple items are stored at the same time.

However, the values set after transmitting this command will not be recorded.

The input should not be turned off for at least five seconds after this command is transmitted.

Otherwise, it may not properly be recorded in the non-volatile memory.

Do not transmit "STORE_USER_ALL" command and this command continuously within 5 seconds. If the process is not completed, this command is not accepted and an error is returned.

(Device busy : Refer to 6.8.3)

6.9.5 RESTORE_DEFAULT_ALL [12h] Send

PAGE

This command restore values and settings in the non-volatile memory of the AME stored by "STORE_USER_ALL" command to the factory defaults.

This command stores settings of target module selected by "PAGE" command in non-volatile memory of each module.

This command needs to be executed to every target module individually.

Even if this command is sent, the setting will not return to the factory default while the input voltage is being applied.

When the input voltage is turned off after transmitting this command, the factory default will be restored after turning the input on.

The input should not be turned off for at least five seconds after this command is transmitted.

Otherwise, it may not properly be recorded in the nonvolatile memory.

Do not transmit "SYS_STORE_USER_SETTING" command and this command continuously within 5 seconds. If the process is not completed, this command is not accepted and an error is returned.

(Device busy : Refer to 6.8.3)

Table 6.9.1 "SYS_STORE_USER_SETTING" Operation example 1 (AM06-BBBB)

Operation	ON/OFF setting *1	Remark
1 Power on	11111b	
2 Send "MFR_OPERATION_SLOT" & "11010b"	11010b	
3 Send "PAGE" & "0"	11010b	Select Input module
4 Send "STORE_USER_ALL"	11010b	
5 Input voltage off	-	
6 Input voltage on	11010b	
7 Send "PAGE" & "0"	11010b	Select Input module
8 Send "RESTORE_DEFAULT_ALL"	11010b	
9 Input voltage off	-	
10 Input voltage on	11111b	

*1 When confirmed by the MFR_OPERATION_SLOT command

Table 6.9.2 "SYS_STORE_USER_SETTING" Operation example 2 (AM06-BBBB)

Operation	ON/OFF setting #1	Remark
1 Power on	12.0V	
2 Send "PAGE" & "1"	12.0V	Select slot 1
3 Send "VOUT_COMMAND" & "10"	10.0V	
4 Send "STORE_USER_ALL"	10.0V	
5 Input voltage off	0V	
6 Input voltage on	10.0V	
7 Send "PAGE" & "2"	10.0V	Select slot 2
8 Send "RESTORE_DEFAULT_ALL"	10.0V	
9 Input voltage off	0V	
10 Input voltage on	10.0V	
11 Send "PAGE" & "1"	10.0V	Select slot 1
12 Send "RESTORE_DEFAULT_ALL"	10.0V	
13 Input voltage off	0V	
14 Input voltage on	12.0V	

6.9.6 MFR_ACCUMULATE_MODE [F6h] R/W Byte

This command sets the Accumulate mode. The Accumulate mode means that Write and Send command (Refer to Table 6.1) will not be executed immediately.

As an exception, "MFR_ACCUMULATE_EXEC" command and "MFR_CLEAR_ACCUMULATE_DATA" command are immediately executed.

bit	7	6	5	4	3	2	1	0	Remark
Initial setting	0	0	0	0	0	0	0	0	00h
Access	R	R	R	R	R	R	R	R/W	

No.	bit	Value	Explanation
1	bit7-1	0000000	None
2	bit0	0	Disables the accumulation mode
3		1	Enables the accumulation mode

In the Accumulate mode, the Write and Send command is buffered internally and is not immediately reflected in the product operation. When transmitting "MFR_ACCUMULATE_EXEC" command, the command in the buffer will be reflected in the operation.

Only one command can be held because the buffer is overwritten.

Because no internal processing is performed at the time of buffering, any software errors other than checksum errors are not returned.

The contents of the buffer are not stored in the non-volatile memory.

6.9.7 MFR_ACCUMULATE_EXEC [F7h] Send

When the Accumulate mode is enabled, the contents in the buffer are executed by sending this command. If this command was transmitted with the buffer empty, an error will be returned.

6.9.8 MFR_READ_ACCUMULATE_DATA [F8h] Read Word

When accumulation mode is enabled, sending this command will return the arguments of the buffered command. If the buffered command is in the Write Byte format (argument 8 bits), the lower 8 bits of the 16 bits to be returned will be the argument, The upper 8 bits are 00h.

When the buffered command is Send format (no argument), the lower 8 bits of 16 bits to be returned are buffered. It becomes a command code, and the upper 8 bits become 00h.

If this command is sent while the buffer is empty, a communication error will occur.

Table6.9.3 MFR_READ_ACCUMULATE_DATA Operation example (AM06-xxxB)

Operation		Return value	AME Output
1	Power on	—	12.0V
2	Send "PAGE" & "1"	—	12.0V
3	Send "VOUT_COMMAND" & "10"	—	10.0V
4	Enable accumulate mode by "MFR_ACCMULATE_MODE"	—	10.0V
5	Set output OFF by "OPERATION"	—	10.0V
6	Send "VOUT_COMMAND" & "8"	—	10.0V
7	Send "MFR_READ_ACCUMULATE_DATA"	8.0V	10.0V
8	Send "MFR_ACCMULATE_EXEC"	—	8.0V

6.9.9 MFR_CLEAR_ACCUMULATE_DATA [F9h] Send

This command deletes contents in the buffer.

6.9.10 MFR_ADDRESS [D4h] R/W Byte

Selects the method of setting the communication address and the address.

Sets the communication address to the value specified by the argument.

However, when the argument is "128", the address becomes the value specified by the ADDR terminal.

The address of the reply packet is that specified by this command.

At time of factory shipment, the argument is set to "128" corresponding to the ADDR terminal setting.

bit	7	6	5	4	3	2	1	0	Remark
Initial setting	0	0	0	1	0	1	1	1	17h
Access	R/W	R	R	R	R	R/W	R/W	R/W	

No.	bit	Value	Explanation
1	bit7	0	Corresponds to the ADDR terminal setting
2		1	Corresponds to the ADDR bit6-0 setting
3	bit6-3	0010	PMBus address (7bit) of High-order 4 bits (Fixed value)
4	bit2-0	000 - 111	PMBus address (7bit) of Lower 3 bits

6.9.11 MFR_READ_ADDRESS [EDh] Read Byte

Returns current communication address.

bit	7	6	5	4	3	2	1	0	Remark
Initial setting	0	0	0	1	0	1	1	1	17h
Access	R	R	R	R	R	R	R	R	

No.	bit	Value	Explanation
1	bit7	0	None
2	bit6-3	0010	PMBus address (7bit) of High-order 4 bits (Fixed value)
3	bit2-0	000 - 111	PMBus address (7bit) of Lower 3 bits

6.10 Commands to acquire product information

6.10.1 PMBUS_REVISION [98h] Read Byte

This command returns the revision of the PMBus implemented in the converter.

bit	7	6	5	4	3	2	1	0	Remark
Initial setting	0	0	1	0	0	0	1	0	22h
Access	R	R	R	R	R	R	R	R	

No.	bit	Value	Explanation
1	bit7-4	0000	Part I Revision 1.0
2		0001	Part I Revision 1.1
3		0010	Part I Revision 1.2
4	bit3-0	0000	Part II Revision 1.0
5		0001	Part II Revision 1.1
6		0010	Part II Revision 1.2

6.10.2 MFR_SERIAL [9Eh] Block Read

Returns the serial number and the lot number, unique to the product.

Display format	ASCII
Examples	9999999-999

6.10.3 MFR_MODEL [9Ah] Block Read

PAGE

This command returns the **order name** of the converter.

Display format	ASCII
Examples(PAGE:0)	AM12-ABCDEO-□□□□□□ □ : Alphanumeric
Examples(PAGE:2)	E ※Output module code installed in the target slot

6.10.4 MFR_LOCATION [9Ch] Block Read

Returns manufacturing location of the product.

Display format	ASCII
Examples	COSEL CO.,LTD.TOYAMA

6.10.5 MFR_RATED_VOUT [FAh] Read Word

PAGE

This command returns the rated voltage of the selected model.

Display format	Linear (Vout)
----------------	---------------

If the input module is target, an error is returned.

If the instruction is executed on an output module other than the supported output modules, an error is returned.

(PAGE selection error : Refer to 6.8.8)

6.10.6 MFR_RATED_IOUT [FBh] Read Word

PAGE

This command returns the rated current of the selected model.

Display format	Linear (Iout)
----------------	---------------

If the input module is target, an error is returned.

If the instruction is executed on an output module other than the supported output modules, an error is returned.

(PAGE selection error : Refer to 6.8.8)

Appendix. Availability and accuracy of PMBus commands

Appendix Support and precision (1/3)

PMBus commands	Support/precision(Ta=25°C Vo:*1)					Note
	Input module	Output module				
		A-D,J-M	E-H,S-V *2	2B-2M	P-R	
Commands to turn output voltage on/off						
OPERATION	○	○	○	○	○	
MFR_OPERATION_STATE	-	○	○	○	-	
MFR_OPERATION_SLOT	○	○	○	○	○	
MFR_GI	○	-	-	-	-	
MFR_CTL_RESET_LATCH	○	-	-	-	-	
Commands to set output voltage						
VOUT_MODE	-	○	○	○	-	
VOUT_COMMAND	-	±1%FS	±0.5%FS	±0.5%FS	-	
MFR_VOUT_FACTORY_SETTING	-	○	○	○	-	
MFR_VOUT_REFERENCE	-	○	○	○	-	
VOUT_MAX	-	○	○	○	-	
MFR_VOUT_MIN	-	○	○	○	-	
MFR_VOUT_LIMIT_FACTORY_SETTING	-	○	○	○	-	
Commands to set constant current						
MFR_CC_MODE	-	-	○	○	-	
MFR_CC	-	-	±2%FS	±2%FS	-	
MFR_CC_FACTORY_SETTING	-	-	○	○	-	
MFR_CC_REFERENCE	-	-	○	○	-	
MFR_CC_MAX	-	-	○	○	-	
MFR_CC_LIMIT_FACTORY_SETTING	-	-	○	○	-	
MFR_CC_CONTROL	-	-	○	○	-	
Commands to set output voltage sequence						
MFR_TON_DELAY_SLOT	-	±2%*3	±2%*3	±2%*3	±2%*3	*3 ±2%or±50msec
MFR_TON_DELAY_SLOT_FACTORY_SETTING	-	○	○	○	○	
TOFF_DELAY	-	±2%*3	±2%*3	±2%*3	±2%*3	*3 ±2%or±50msec
MFR_TOFF_DELAY_FACTORY_SETTING	-	○	○	○	○	
MFR_TON_DELAY_VIN	±2%*3	-	-	-	-	*3 ±2%or±50msec
MFR_RAMP_RATE	-	-	○	○	-	
VIN_ON	±3%FS	-	-	-	-	
VIN_OFF	±3%FS	-	-	-	-	
Commands to set accessory functions						
MFR_FAN_MODE	○	-	-	-	-	
MFR_AUX_VOUT	±5%FS	-	-	-	-	
VIN_UV_WARN_LIMIT	○	-	-	-	-	

*1 Output module A-D,J-M : 80% - 100%
Output module E-H,S-U,2B-2M : 60% - 100%
Output module V : 76.8% - 100%

*2 Include E4-H4, V4, and V5

Appendix Support and precision (2/3)

PMBus commands	Support/precision(Ta=25°C Vo:*1)					Note
	Input module	Output module				
		A-D,J-M	E-H,S-V *2	2B-2M	P-R	
Monitor commands						
READ_VIN	±3%FS	-	-	-	-	
MFR_READ_VIN_FREQUENCY	±1Hz	-	-	-	-	
READ_VOUT	-	±1%FS	±1%FS	±1%FS	-	
READ_IOUT	-	-	±2%FS	±2%FS	-	
READ_POUT	-	-	±2%FS	±2%FS	-	
READ_FAN_SPEED_1	±500rpm	-	-	-	-	
READ_FAN_SPEED_2	±500rpm*3	-	-	-	-	
READ_TEMPERATURE_1	±5deg*4	-	-	-	-	
State acquisition commands						
CLEAR_FAULTS	○	-	-	-	-	
SMBALERT_MASK	○	-	-	-	-	
STATUS_BYTE	○	-	-	-	-	
STATUS_WORD	○	-	-	-	-	
STATUS_INPUT	○	-	-	-	-	
STATUS_TEMPERATURE	○	-	-	-	-	
STATUS_CML	○	-	-	-	-	
STATUS_MFR_SPECIFIC	○	-	-	-	-	
STATUS_FANS_1_2	○	-	-	-	-	
MFR_ARA_CONFIG	○	-	-	-	-	
MFR_STOP_CODE	○	○	○	○	-	
MFR_READ_TOTAL_INPUT_TIME_1	○	-	-	-	-	
MFR_READ_TOTAL_INPUT_TIME_2	○	-	-	-	-	
MFR_READ_TOTAL_INPUT_TIME_3	○	-	-	-	-	
MFR_READ_TOTAL_OUTPUT_TIME_1	○	○	○	○	-	
MFR_READ_TOTAL_OUTPUT_TIME_2	○	○	○	○	-	
MFR_READ_TOTAL_OUTPUT_TIME_3	○	○	○	○	-	

- *1 Output module A-D,J-M : 80% - 100%
 Output module E-H,S-U,2B-2M : 60% - 100%
 Output module V : 76.8% - 100%

*2 Include E4-H4, V4, and V5

*3 This command is only for AME800F and AME1200F

*4 The value at -20 to 100°C. Indicates the accuracy to the actual temperature of the measurement point.
 Not Ambient temperature. The value also affected by fan speed.

Appendix Support and precision (3/3)

PMBus commands	Support/precision(Ta=25°C Vo:*1)					Note
	Input module	Output module				
		A-D,J-M	E-H,S-V *2	2B-2M	P-R	
Commands to set address, memory, and communication						
PAGE	○	○	○	○	○	
CAPABILITY	○	-	-	-	-	
WRITE_PROTECT	○	-	-	-	-	
STORE_USER_ALL	○	○	○	○	-	
RESTORE_DEFAULT_ALL	○	○	○	○	-	
MFR_ACCUMULATE_MODE	○	-	-	-	-	
MFR_ACCUMULATE_EXEC	○	-	-	-	-	
MFR_READ_ACCUMULATE_DATA	○	-	-	-	-	
MFR_CLEAR_ACCUMULATE_DATA	○	-	-	-	-	
MFR_ADDRESS	○	-	-	-	-	
MFR_READ_ADDRESS	○	-	-	-	-	
Commands to acquire product information						
PMBUS_REVISION	○	-	-	-	-	
MFR_SERIAL	○	-	-	-	-	
MFR_MODEL	○	○	○	--*5	○	
MFR_LOCATION	○	-	-	-	-	
MFR_RATED_VOUT	-	○	○	○	-	
MFR_RATED_IOUT	-	○	○	○	-	

*1 Output module A-D,J-M : 80% - 100%
 Output module E-H,S-U,2B-2M : 60% - 100%
 Output module V : 76.8% - 100%

*2 Include E4-H4, V4, and V5

*5 When this command is executed on the 2B-2M output module, it returns '2'.
 Refer to the order model name of the input module.

index

Command code order

Code	Command	Item No.	Page	Code	Command	Item No.	Page
00h	PAGE	6.9.1	32	DBh	MFR_RAMP_RATE	6.5.6	22
01h	OPERATION	6.2.1	11	DCh	MFR_AUX_VOUT	6.6.2	24
03h	CLEAR_FAULTS	6.8.1	27	DFh	MFR_CC_CONTROL	6.4.7	18
10h	WRITE_PROTECT	6.9.3	34	E0h	MFR_ARA_CONFIG	6.8.10	30
12h	RESTORE_DEFAULT_A	6.9.5	36	E1h	MFR_CTL_RESET_LATCH	6.2.5	13
15h	STORE_USER_ALL	6.9.4	35	E3h	MFR_VOUT_FACTORY_SETTING	6.3.3	16
19h	CAPABILITY	6.9.2	34	E4h	MFR_CC_FACTORY_SETTING	6.4.3	17
1Bh	SMBALERT_MASK	6.8.2	27	E5h	MFR_VOUT_LIMIT_FACTORY_SETTING	6.3.7	16
20h	VOUT_MODE	6.3.1	15	E6h	MFR_CC_LIMIT_FACTORY_SETTING	6.4.6	18
21h	VOUT_COMMAND	6.3.2	15	E7h	MFR_TON_DELAY_SLOT_FACTORY_SET	6.5.2	19
24h	VOUT_MAX	6.3.5	16	E8h	MFR_TOFF_DELAY_FACTORY_SETTING	6.5.4	20
35h	VIN_ON	6.5.7	23	E9h	MFR_READ_VIN_FREQUENCY	6.7.2	25
36h	VIN_OFF	6.5.8	23	EAh	MFR_VOUT_REFERENCE	6.3.4	16
58h	VIN_UV_WARN_LIMIT	6.6.3	24	EBh	MFR_CC_REFERENCE	6.4.4	18
64h	TOFF_DELAY	6.5.3	20	EDh	MFR_READ_ADDRESS	6.9.11	38
78h	STATUS_BYTE	6.8.3	27	EEh	MFR_OPERATION_STATE	6.2.2	12
79h	STATUS_WORD	6.8.4	28	EFh	MFR_READ_TOTAL_INPUT_TIME_1	6.8.12	31
7Ch	STATUS_INPUT	6.8.5	28	F0h	MFR_READ_TOTAL_INPUT_TIME_2	6.8.12	31
7Dh	STATUS_TEMPERATURE	6.8.6	28	F1h	MFR_READ_TOTAL_INPUT_TIME_3	6.8.12	31
7Eh	STATUS_CML	6.8.7	29	F2h	MFR_READ_TOTAL_OUTPUT_TIME_1	6.8.13	31
80h	STATUS_MFR_SPECIFI	6.8.8	29	F3h	MFR_READ_TOTAL_OUTPUT_TIME_2	6.8.13	31
81h	STATUS_FANS_1_2	6.8.9	29	F4h	MFR_READ_TOTAL_OUTPUT_TIME_3	6.8.13	31
88h	READ_VIN	6.7.1	25	F6h	MFR_ACCUMULATE_MODE	6.9.6	37
8Bh	READ_VOUT	6.7.3	25	F7h	MFR_ACCUMULATE_EXEC	6.9.7	37
8Ch	READ_IOUT	6.7.4	25	F8h	MFR_READ_ACCUMULATE_DATA	6.9.8	38
8Dh	READ_TEMPERATURE	6.7.8	26	F9h	MFR_CLEAR_ACCUMULATE_DATA	6.9.9	38
90h	READ_FAN_SPEED_1	6.7.6	26	FAh	MFR_RATED_VOUT	6.10.5	39
91h	READ_FAN_SPEED_2	6.7.7	26	FBh	MFR_RATED_IOUT	6.10.6	39
96h	READ_POUT	6.7.5	25	FC	MFR_STOP_CODE	6.8.11	30
98h	PMBUS_REVISION	6.10.1	39				
9Ah	MFR_MODEL	6.10.3	39				
9Ch	MFR_LOCATION	6.10.4	39				
9Eh	MFR_SERIAL	6.10.2	39				
D0h	MFR_CC	6.4.2	17				
D1h	MFR_CC_MODE	6.4.1	17				
D2h	MFR_CC_MAX	6.4.5	18				
D3h	MFR_VOUT_MIN	6.3.6	16				
D4h	MFR_ADDRESS	6.9.10	38				
D6h	MFR_FAN_MODE	6.6.1	24				
D7h	MFR_GI	6.2.4	13				
D8h	MFR_OPERATION_SLC	6.2.3	12				
D9h	MFR_TON_DELAY_SLC	6.5.1	19				
DAh	MFR_TON_DELAY_VIN	6.5.5	21				

A. Revision history

No.	Date	Ver	Page	Note
1	2020.2.21	1.0E	-	First edition issued
2	2020.11.13	1.1E	7	5.3 has been added
3			13	Revised MFR_GI [D7h]
4			26	Revised STATUS_BYTE [78h]
5			34	Revised STORE_USER_ALL [15h]
6			Appendix-2	Revised "※4"
7			-	Corresponds to module J-M, E4-H4, R
8			2021.9.10	1.2E
9	-	Corresponds to module S-V, V4, V5		
10	2021.12.20	1.3E	-	Only the version number is up
11	2021.12.20	1.4E	14	Revised VOUT_MODE [20h]
12			24	Revised READ_VOUT [8Bh]
13			29	Revised MFR_STOP_CODE [FCh]
14			31,32	Revised PAGE [00h]
15			Appendix-1	Revised Appendix Support and precision (1/3)
16			2022.11.24	1.5E
17	12	Revised MFR_OPARATION_SLOT [D8h]		
18	13	Revised MFR_GI [D7h]		
19	14	"About a combination of commands to turn output voltage on/off" has been added.		
20				
21	2026.4.2	1.6E	-	Corresponds to module 2B-2M, P,Q
22				
23				
24				
25				
26				
27				
28				
29				
30				